



EXPERIENCE THE EXCEPTIONAL

Mixer Seals

Seal range designed for mixers, agitators and reactors



the AESSEAL® group of companies

designers and manufacturers of mechanical seals,
bearing protectors and seal support systems
which maximize rotating equipment up-time.



www.aesseal.com



Company Overview

AESSEAL® is a leading global specialist in the design and manufacture of mechanical seals, bearing protectors and seal support systems.

The company sets new standards in reliability, performance, service and cost. Service has been the key to the success of AESSEAL® and is at the core of the company purpose statement — **‘to give our customers such exceptional service that they need never consider alternative sources of supply.’** Through continuous investment, unique modular technology and an unparalleled dedication to customer service we aim to constantly exceed expectation.

Customer Focus

“We aim to deliver a customer experience that surpasses expectation and truly redefines what the world expects from their sealing specialist.”

Simplicity. Our modular technology means a streamlined ordering process.

Customer-centric. Our people are encouraged to champion the customers’ cause.

Ethical and responsible. AESSEAL® has been recognized as a Climate Change Champion and has won awards for corporate social responsibility and sustainability.

Partnership. We work with customers to deliver added value and long-term reliability solutions.

Investment. Over 7% of annual sales revenue has been reinvested in R&D over several decades. This has almost certainly led to the most advanced range of sealing technology available globally.

Engineered Excellence

AESSEAL® offers a complete product range to seal Mixers, Agitators and Reactors.

- Hydraulically balanced for reduced seal-face loading which maximizes seal life and allows for vacuum service capability
- Unitized design for ease of installation
- Non-fretting design to reduce cost in equipment overhaul
- Modular designs for improved versatility

The range of AESSEAL® Mixer mechanical seals are designed for mixers, agitators, reactors and dryers.

Mixing applications vary from simple blending or solid dissolution to the more exacting standards of solids suspension, gas dispersion or containing / promoting chemical reactions.

Mixers are used in the food, beverage and pharmaceutical industries, yet generally the chemical and process industries have the most varied and difficult mixer problems and therefore require precise sealing technology. The AESSEAL® Mixer seal range ensures that the most demanding applications can be accommodated. For more information this brochure can be downloaded from the AESSEAL® website at www.aesseal.com.

Development Background

The AESSEAL® Mixer range was developed only after extensive performance and field evaluation tests, conducted over many years.

The range has been created using the latest Computer Aided Design and manufacture programs including Finite Element Analysis.

These programs help to predict how the seals can be produced and also how they will perform under various application conditions. This technology has vastly reduced the lead time for product development and thus reduced the overall cost of the seal range.

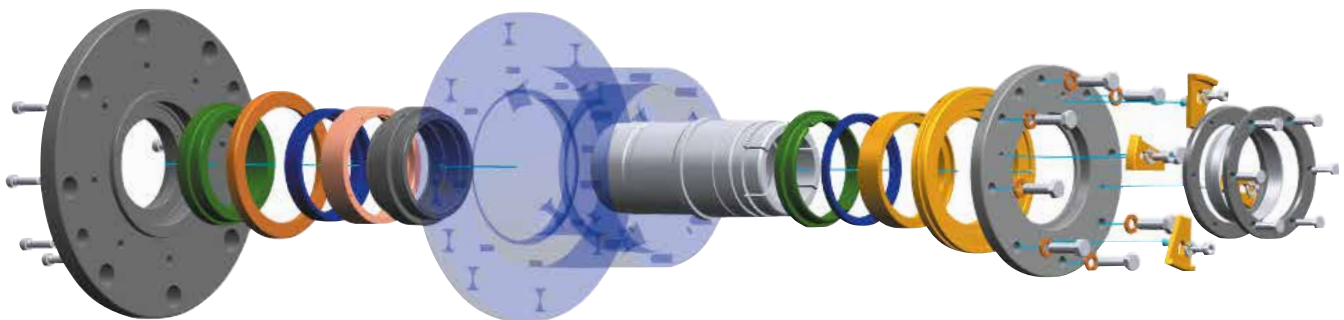

Exploded view of a Mixmaster IV™

Massive investment in Computer Aided Design, manufacture and PDM (Product Data Management) helps to ensure that the seal is fit for the purpose.

Computer simulation is very effective for evaluating seal performance, however, all AESSEAL® mechanical seals still have to undergo physical testing in various hazardous conditions.



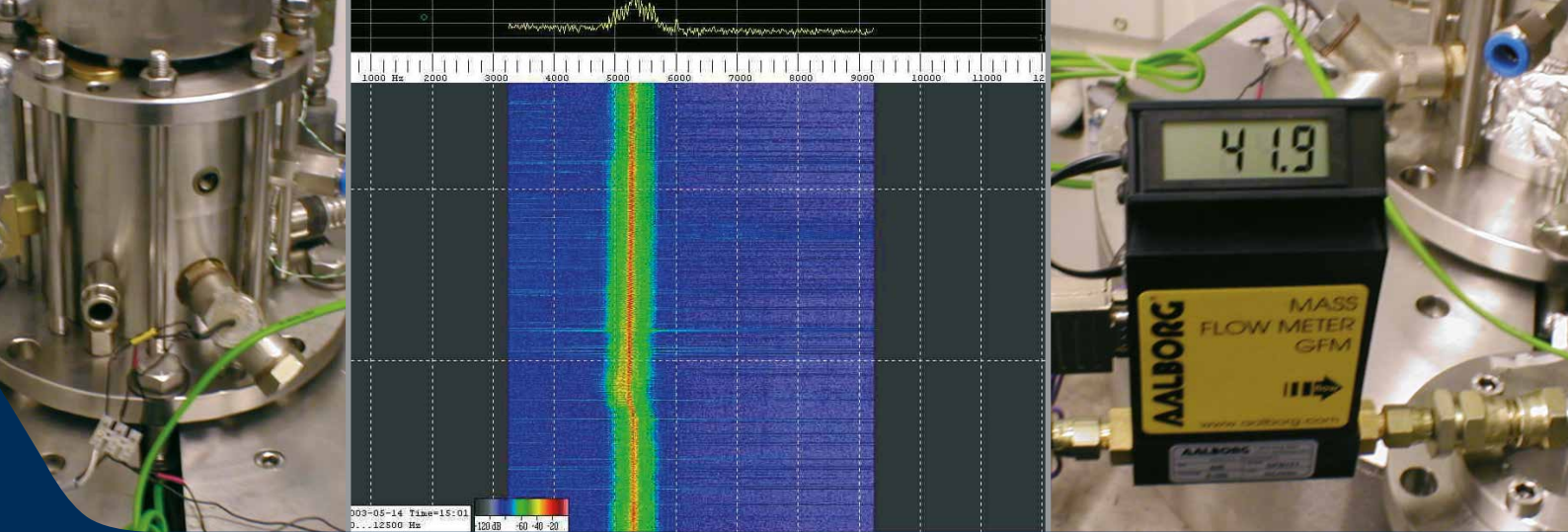

Sound level metering, spectrum analysis, gas flow and temperature instrumentation and continuous data logging software

The AESSEAL® Mixer range has been developed following an extensive performance evaluation test program over an 18 month period.

The dry running seal technology, specifically the seal face geometry, damper and close coupled devices, have been created using the latest Computer Aided Design, Manufacture and simulation software.

The product range has been verified and performance optimized using sound level metering, spectrum analysis, gas flow and temperature instrumentation and continuous data logging software. The result is a range of inventoried, patent pending mechanical seals, which extend the boundaries of conventional products, allowing wider application of the technology and benefits.

Various applications, such as horizontal drying, preclude the use of a liquid barrier fluid due to process contamination possibilities.

In such applications, the attraction of an inert non-contaminating barrier fluid is clearly advantageous. By far, the largest demand for gas barrier systems is in the food and pharmaceutical industries. As such, AESSEAL® has developed a range of dry running mechanical seals and seal support systems for such applications and industries.

⊠ ATEX certification available, contact AESSEAL®



ESM™ - External Seal for Mixers

The AESSEAL® ESM™ is a unit external seal designed for ease of installation as the faces are clipped together and despatched assembled in a leak free state.

The standard ESM™ seal is driven through socket set screw clamping, with a Carbon / Ceramic seal face combination and a gland which is designed to suit the customer's equipment. All wetted parts are non-metallic, therefore, the seal is ideally suited for corrosive vapour applications commonly found in Top Entry Mixers.

- Balanced seal face design
- Modular design
- Unit designed for ease of installation
- ESM™, ESCM™, ESTM™, ESCTM™ non-metallic wetted design
- NCM™ non-chemical design
- Springs out of product
- Seal flange manufactured to suit equipment



NCM-DW External Seals for Mixers.
The seal can be used in sterile application particularly suited in the food & Beverage along with the Pharmaceutical sectors.



Sizes Available	1.000" to 2.500"	25mm to 63mm
------------------------	------------------	--------------

Designed for ease of installation the ESM™ has non-metallic wetted parts and is therefore ideally suited for corrosive vapour applications commonly found in Top Entry Mixers.

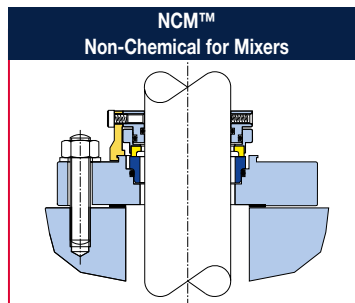

Sizes Available	1.000" to 5.000"	24mm to 125mm
------------------------	------------------	---------------

The NCM™ is an external seal unit designed for ease of installation, as the faces are clipped together and despatched assembled in a leak free state. Some wetted parts are metallic, therefore the seal is unsuited for some severe corrosive applications.

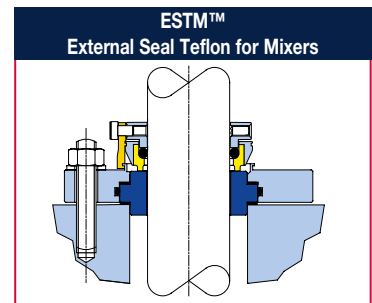

Sizes Available	1.000" to 2.500"	25mm to 63mm
------------------------	------------------	--------------

A sister variant on the ESM™, the ESTM™ replaces the Carbon / Ceramic face combination with Teflon (P.T.F.E.) / Ceramic, for applications where Carbon is not compatible with the process fluid.

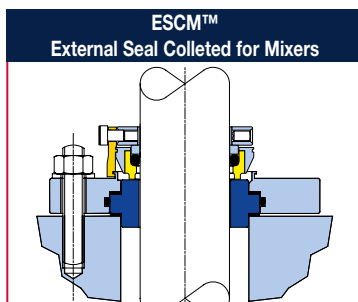

Sizes Available	1.000" to 2.500"	25mm to 63mm
------------------------	------------------	--------------

The ESCM™ employs the same seal principles as the ESM™ except for the clamping device. The ESCM™ utilizes a collet clamp ring making the unit particularly applicable to hard and soft shafts.

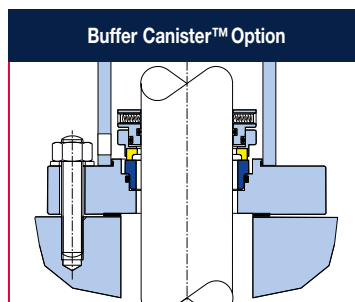

Buffer Canister™ option available on	ESM™ - NCM™ - ESTM™ - ESCM™ - ESCTM™
---	--------------------------------------

The buffer canister option is available on both the ESM™ and NCM™ range of unit seals. The simple design can be of an open or closed top construction and slides over the external seal. An O'ring is then placed in the clip groove to prevent leakage. The fluid in the canister "bathes" the seal faces and therefore is applicable for the dry running applications which are commonly found in top entry mixers.

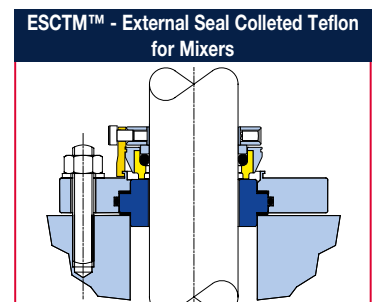

Sizes Available	1.000" to 2.500"	25mm to 63mm
------------------------	------------------	--------------

A hybrid unit seal of the previous options. The ESCTM™ offers a Teflon / Ceramic face combination, collet clamping and gland designed to suit the customer's equipment. All wetted parts are non-metallic.

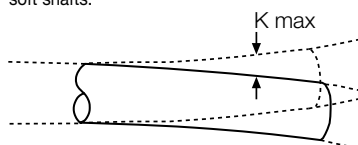

ESM™ - ESCM™ - ESTM™ - ESCTM™	
Seal Size	T.I.R. (K max)
1.000" to 1.500"	0.030"
25mm to 38mm	0.8mm
1.625" to 2.500"	0.040"
40mm to 63mm	1.0mm

Seal Type	Face Availability	Drive
ESM™	CAR - CER	Standard
ESCM™	CAR - CER	Collet
ESTM™	PTFE - CER	Standard
ESCTM™	PTFE - CER	Collet
NCM™	Rotary Face	Standard
	Car - SiC - TC	
	Stationary Face	
	CROX-CER-SiC-TC	

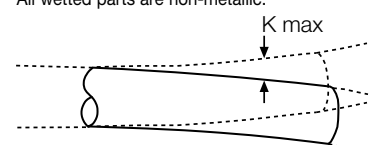

NCM™	
Seal Size	T.I.R. (K max)
1.000" to 2.375"	0.040"
24mm to 60mm	1.0mm
2.500" to 5.000"	0.060"
40mm to 63mm	1.5mm

Mixmaster I™ - CSWIB™

The AESSEAL® Mixmaster I™ is a single cartridge mechanical seal, with balanced seal faces and an integral (steady) bearing.



The Mixmaster I™ can be ordered in types B, C & D in a variety of gland combinations concerning flush, quench, drain and grease connections and also different face combinations. The gland plate is machined to meet the customer's requirements with respect to outside diameter, bolt circle diameter and stuffing box location.

CSWIB™ - Dimensional Information (inches)

ØA	ØB	ØC		ØD		ØE	F	G	H
		Min	Max	Min	Max				
1.000		1.663		3.000		3/8	1.750	1.150	2.312
1.125		1.780		3.250		3/8	1.750	1.150	2.312
1.250		1.931		3.500		3/8	1.750	1.150	2.312
1.375		2.056		3.500		3/8	1.750	1.150	2.312
1.500		2.303		3.875		1/2	1.812	1.187	2.375
1.625		2.428		4.500		1/2	1.812	1.187	2.375
1.750		2.553		4.500		1/2	1.812	1.187	2.375
1.875		2.678		4.625		1/2	1.812	1.312	2.375
2.000		2.803		4.625		1/2	1.812	1.312	2.375
2.125		2.928		4.937		1/2	1.812	1.312	2.375
2.250		3.053		5.000		5/8	1.812	1.312	2.375
2.375		3.178		5.375		5/8	1.812	1.312	2.375
2.500		3.428		5.500		5/8	2.000	1.312	2.625
2.625		3.553		5.500		5/8	2.000	1.312	2.625
2.750		3.678		5.875		5/8	2.062	1.312	2.625
2.875		3.803		6.125		5/8	2.062	1.312	2.625
3.000		3.928		6.125		5/8	2.062	1.312	2.625
3.125		4.053		6.500		5/8	2.062	1.312	2.625
3.250		4.178		6.625		3/4	2.062	1.312	2.625
3.375		4.303		6.875		3/4	2.062	1.312	2.625
3.500		4.428		6.875		3/4	2.062	1.312	2.625
3.625		4.553		7.375		3/4	2.062	1.312	2.625
3.750		4.678		7.375		3/4	2.062	1.312	2.625
3.875		4.803		7.875		3/4	2.125	1.312	2.625
4.000		4.928		7.875		3/4	2.125	1.312	2.625

Dependent upon application

Dependent upon application

Dependent upon application

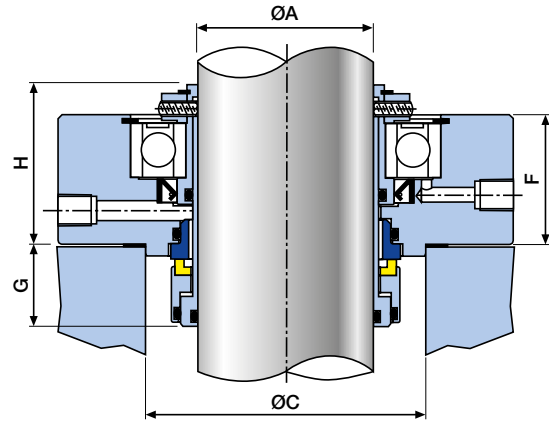

Type B
Quench, Drain & Grease Connections

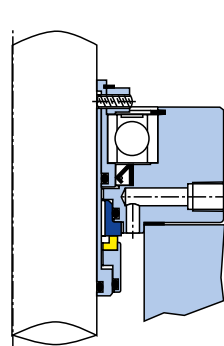

Type C
Type B Design with
Flush

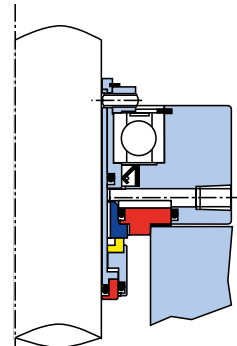

Type D
Exotic Alloy Option with
Quench, Drain & Grease
Connections

Note: ØE, F, G, H are typical sizes only. This seal design is made to suit customer requirements and these sizes can be changed.

CSWIB™ - Dimensional Information (mm)

ØA	ØB	ØC		ØD		ØE	F	G	H
		Min	Max	Min	Max				
24		41.2		76.2		10	44.5	29.2	58.7
25		42.2		76.2		10	44.5	29.2	58.7
28		45.2		82.6		10	44.5	29.2	58.7
30		47.2		82.6		10	44.5	29.2	58.7
32		49.0		88.9		10	44.5	29.2	58.7
33		49.0		88.9		10	44.5	29.2	58.7
35		52.2		88.9		10	44.5	29.2	58.7
38		58.5		98.4		12	46.0	30.1	60.3
40		58.5		98.4		12	46.0	30.1	60.3
43		61.7		114.3		12	46.0	30.1	60.3
45		64.8		114.3		12	46.0	30.1	60.3
48		68.0		117.5		12	46.0	33.3	60.3
50		68.0		117.5		12	46.0	33.3	60.3
53		71.2		117.5		12	46.0	33.3	60.3
55		74.4		125.4		12	46.0	33.3	60.3
58		77.5		136.5		16	46.0	33.3	60.3
60		80.7		136.5		16	46.0	33.3	60.3
63		87.1		139.7		16	50.8	33.3	66.7
65		90.2		139.7		16	50.8	33.3	66.7
68		93.4		149.2		16	52.4	33.3	66.7
70		93.4		149.2		16	52.4	33.3	66.7
75		99.8		155.6		16	52.4	33.3	66.7
80		102.9		165.1		16	52.4	33.3	66.7
85		109.3		174.6		20	52.4	33.3	66.7
90		115.6		187.3		20	52.4	33.3	66.7
95		118.8		187.3		20	52.4	33.3	66.7
100		125.2		200.0		20	54.0	33.3	66.7

Dependent upon application

Dependent upon application

Dependent upon application

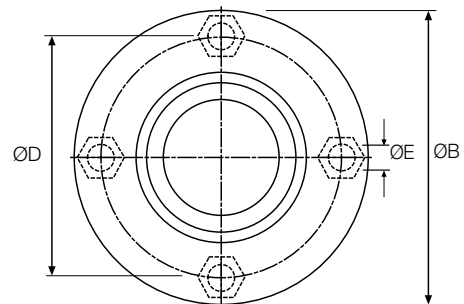

Minimum bolt circle based on bolt size shown.

Mixmaster II™ - DSWIB™

The AESSEAL® Mixmaster II™ is a double cartridge seal with integral bearing design with concentric faces so that the seals overall length is reduced.



The CSWIB™ & DSWIB™ are offered with the following features:

- The integral bearing (pre-installed) is designed as a steady bearing and may not take the full radial load applied to a mixer
- Quench drain & grease connections as standard
- Available with flush connection (type 'C' only)
- No shaft fretting
- Balanced seal faces
- Non-clogging rotaries
- Most suitable for low shaft speeds
- Supplied with high tensile, corrosion resistant socket set screws

The Mixmaster II™ can be ordered in types B, C & D.

Like the Mixmaster I™, the Mixmaster II™ seal is manufactured from a fully machined gland, to the customer's specification.

Note: All face combinations up to 3.250" are standard AESSEAL® face materials. Contact the AESSEAL® technical department for hard face options above this size.

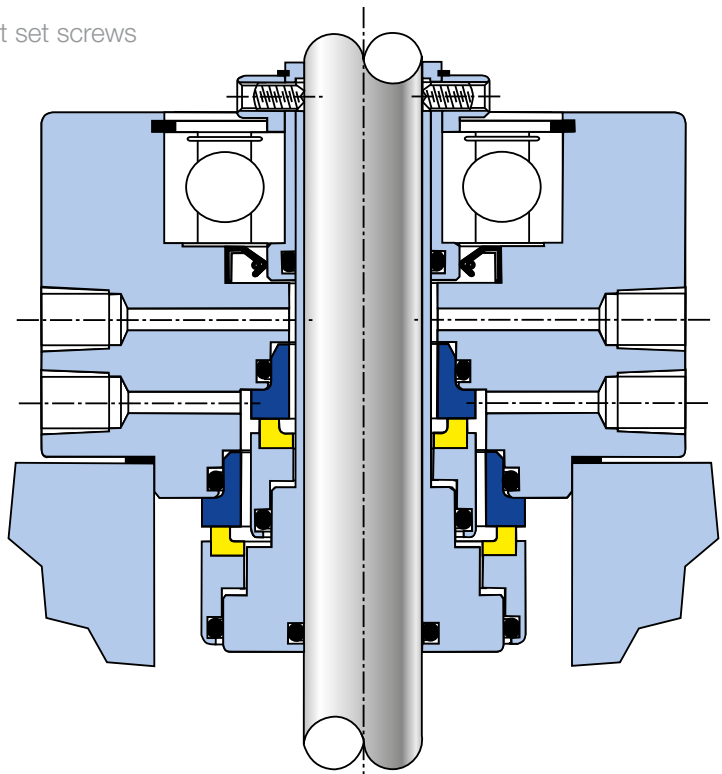

DSWIB™ - (inches)

ØA	ØB	ØC	
		Min	Max
1.000		2.303	
1.125		2.428	
1.250		2.553	
1.375		2.678	
1.500		2.928	
1.625		3.053	
1.750		3.178	
1.875		3.428	
2.000		3.553	
2.125		3.678	
2.250		3.803	
2.375		3.928	
2.500		4.178	
2.625		4.303	
2.750		4.428	
2.875		4.553	
3.000		4.678	
3.125		4.803	
3.250		4.928	
3.375		5.178	
3.500		5.178	
3.625		5.428	
3.750		5.428	
3.875		5.678	
4.000		5.678	

Dependent upon application

DSWIB™ - (mm)

ØA	ØB	ØC	
		Min	Max
24		58.5	
25		58.5	
28		61.7	
30		61.7	
32		64.8	
33		64.8	
35		68.0	
38		74.4	
40		74.4	
43		77.5	
45		80.7	
48		87.1	
50		87.1	
53		90.2	
55		93.4	
58		96.6	
60		99.8	
63		106.1	
65		109.3	
68		112.5	
70		112.5	
75		118.8	
80		122.0	
85		131.5	
90		137.9	
95		137.9	
100		144.2	

Dependent upon application

CSM™ - Cartridge Single for Mixers



The AESSEAL® CSM™ is available in a wide range of seal face, elastomer and alloy combinations, to suit individual applications.

Single cartridge seal for mixers / agitators.

Designed to run in vapour on vertical applications, with low emissions.

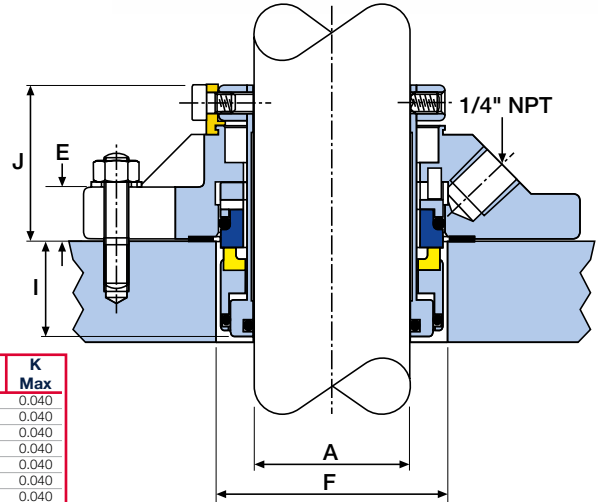

CSM™ - Dimensional Information (inches)

A	B	C	D	E	Min	F Min†	Max	Min	G Max	H Max	I	J	K Max
1.000	4.125	2.125	1.937	0.519	1.625	1.665	1.937	2.687	3.562	1/2	1.125	1.590	0.040
1.125	4.250	2.250	2.063	0.519	1.750	1.790	2.062	2.812	3.687	1/2	1.125	1.590	0.040
1.250	4.375	2.375	2.187	0.519	1.875	1.915	2.187	2.937	3.812	1/2	1.125	1.590	0.040
1.375	4.375	2.500	2.312	0.519	2.000	2.040	2.250	3.062	3.812	1/2	1.125	1.590	0.040
1.500	5.000	2.812	2.562	0.644	2.250	2.290	2.375	3.375	4.437	1/2	1.125	1.752	0.040
1.625	5.000	2.812	2.562	0.644	2.375	2.415	2.500	3.375	4.437	1/2	1.125	1.752	0.040
1.750	5.500	3.187	2.812	0.644	2.500	2.540	2.750	3.750	4.937	1/2	1.125	1.752	0.040
1.875	5.500	3.187	2.812	0.644	2.625	2.665	2.875	3.750	4.937	1/2	1.125	1.752	0.040
2.000	6.000	3.562	3.063	0.644	2.750	2.790	3.000	4.125	5.437	1/2	1.125	1.752	0.040
2.000-AC	5.250	3.450	3.035	0.644	2.750	2.790	3.000	4.000	4.750	1/2	1.125	1.752	0.040
2.125	6.000	3.562	3.063	0.644	2.875	2.915	3.125	4.125	5.437	1/2	1.125	1.752	0.040
2.250	6.500	3.812	3.312	0.644	3.000	3.040	3.250	4.500	5.812	5/8	1.125	1.752	0.040
2.375	6.500	3.812	3.312	0.644	3.125	3.165	3.375	4.500	5.812	5/8	1.125	1.752	0.040
2.500	7.000	4.312	3.812	0.769	3.375	3.435	3.625	5.000	6.312	5/8	1.250	1.877	0.060
2.625	7.000	4.312	3.812	0.769	3.500	3.560	3.750	5.000	6.312	5/8	1.250	1.877	0.060
2.750	7.000	4.312	3.812	0.769	3.625	3.685	3.875	5.000	6.312	5/8	1.250	1.877	0.060
2.875	7.500	4.937	4.250	0.769	3.750	3.810	4.125	5.625	6.812	5/8	1.250	1.877	0.060
3.000	7.500	4.937	4.250	0.769	3.875	3.935	4.250	5.625	6.812	5/8	1.250	1.877	0.060
3.125	7.500	4.937	4.250	0.769	4.000	4.060	4.375	5.625	6.812	5/8	1.250	1.877	0.060
3.250	8.000	5.312	4.625	0.769	4.125	4.185	4.500	6.125	7.187	3/4	1.250	1.877	0.060
3.375	8.000	5.312	4.625	0.769	4.250	4.310	4.625	6.125	7.187	3/4	1.250	1.877	0.060
3.500	8.000	5.312	4.625	0.769	4.375	4.435	4.750	6.125	7.187	3/4	1.250	1.877	0.060
3.625	8.500	5.937	5.000	0.769	4.500	4.560	5.000	6.750	7.687	3/4	1.250	1.877	0.060
3.750	8.500	5.937	5.000	0.769	4.625	4.685	5.125	6.750	7.687	3/4	1.250	1.877	0.060
3.875	8.500	5.937	5.000	0.769	4.750	4.810	5.250	6.750	7.687	3/4	1.250	1.877	0.060
4.000	9.000	6.625	5.375	0.769	4.875	4.935	5.500	7.437	8.187	3/4	1.250	1.877	0.060
4.125	9.000	6.625	5.375	0.769	5.125	5.185	5.875	7.437	8.187	3/4	1.250	1.877	0.060
4.250	9.000	6.625	5.375	0.769	5.125	5.185	5.875	7.437	8.187	3/4	1.250	1.877	0.060
4.375	9.500	7.000	5.750	0.769	5.375	5.435	6.250	7.812	8.687	3/4	1.250	1.877	0.060
4.500	9.500	7.000	5.750	0.769	5.375	5.435	6.250	7.812	8.687	3/4	1.250	1.877	0.060
4.625	10.000	7.345	6.125	0.769	5.625	5.685	6.625	8.312	9.062	7/8	1.250	1.877	0.060
4.750	10.000	7.345	6.125	0.769	5.625	5.685	6.625	8.312	9.062	7/8	1.250	1.877	0.060
4.875	10.000	7.345	6.125	0.769	5.875	5.935	6.625	8.312	9.062	7/8	1.250	1.877	0.060
5.000	10.000	7.345	6.125	0.769	5.875	5.935	6.625	8.312	9.062	7/8	1.250	1.877	0.060

Seal sizes from 5.125" to 12.000" are designed to suit specific equipment using modular components. Contact AESSEAL® technical department for dimensional information and availability.

† = F Min + K Max

CSM™ - Dry Running

D1 mm	D2 inch	D3 barg	D3 psig	D4 bar m/s	D4 psi ft/min	D5	
25	1.0	300	2	29.4	1.2	3370	70000
25	1.0	600	2	29.4	2.4	6740	40000
25	1.0	900	2	29.4	3.5	10100	14000
25	1.0	300	4	58.7	2.0	5600	50000
25	1.0	600	4	58.7	3.9	11130	9000
25	1.0	300	6	88.1	2.8	7850	21000
50	2.0	300	2	29.4	2.4	6740	40000
50	2.0	600	2	29.4	4.7	13480	6800
50	2.0	300	4	58.7	3.9	11130	9000
50	2.0	100	6	88.1	1.8	5220	50000
50	2.0	200	6	88.1	2.7	7590	21000
75	3.0	100	2	29.4	1.2	3430	70000
75	3.0	300	2	29.4	3.0	8570	16000
75	3.0	100	4	58.7	2.0	5600	40000
75	3.0	100	6	88.1	2.8	7850	21000
100	4.0	100	2	29.4	1.6	4570	60000
100	4.0	200	2	29.4	3.2	9140	21000
100	4.0	100	4	58.7	2.6	7420	30000
100	4.0	50	6	88.1	1.8	5140	70000
100	4.0	100	6	88.1	3.6	10280	13000

The above chart shows a summary of the expected life time for dry running performance of Carbon/Silicon Carbide faces.

D1: Shaft Diameter	D2: Shaft Speed (rpm)	D3: Product Pressure	D4: 'P.V.' Value	D5: Expected Life (hours)
--------------------	-----------------------	----------------------	------------------	---------------------------

CSM™ - Dimensional Information (mm)

A	B	C	D	E	Min	F Min†	Max	Min	G Max	H Max	I	J	K Max
24	104.8	54.0	49.2	13.2	40.0	41.0	46.0	67.0	90.5	12	28.6	40.5	1.0
25	104.8	54.0	49.2	13.2	41.0	42.0	49.0	67.0	90.5	12	28.6	40.5	1.0
28	108.0	57.2	52.4	13.2	44.0	45.0	52.3	70.3	93.6	12	28.6	40.5	1.0
30	111.0	60.4	55.6	13.2	46.0	47.0	55.5	73.5	96.8	12	28.6	40.5	1.0
32	111.0	60.4	55.6	13.2	48.0	49.0	55.5	73.5	96.8	12	28.6	40.5	1.0
33	111.0	60.4	55.6	13.2	49.0	50.0	55.5	73.5	96.8	12	28.6	40.5	1.0
35	111.0	63.5	58.8	13.2	51.0	52.0	57.5	76.6	96.8	12	28.6	40.5	1.0
38	127.0	71.5	65.0	16.4	57.2	58.2	60.4	85.7	114.3	12	28.6	44.5	1.0
40	127.0	71.5	65.0	16.4	58.0	59.0	60.4	85.7	114.3	12	28.6	44.5	1.0
43	139.7	81.0	71.4	16.4	61.0	62.0	69.9	95.3	127.0	12	28.6	44.5	1.0
45	139.7	81.0	71.4	16.4	63.5	64.5	69.9	95.3	127.0	12	28.6	44.5	1.0
48	139.7	81.0	71.4	16.4	66.7	67.7	73.0	95.3	127.0	12	28.6	44.5	1.0
50	152.4	90.5	77.8	16.4	68.0	69.0	76.2	104.8	139.7	12	28.6	44.5	1.0
53	152.4	90.5	77.8	16.4	71.0	72.0	76.2	104.8	139.7	12	28.6	44.5	1.0
55	165.1	96.8	84.1	16.4	74.0	75.0	82.5	114.3	149.2	16	28.6	44.5	1.0
58	165.1	96.8	84.1	16.4	76.2	77.2	82.5	114.3	149.2	16	28.6	44.5	1.0
60	165.1	96.8	84.1	16.4	79.4	80.4	85.7	114.3	149.2	16	28.6	44.5	1.0
63	177.8	109.5	96.8	19.6	85.8	87.3	92.1	127.0	160.3	16	31.8	47.7	1.5
65	177.8	109.5	96.8	19.6	88.9	90.4	95.3	127.0	160.3	16	31.8	47.7	1.5
68	177.8	109.5	96.8	19.6	92.1	93.6	98.4	127.0	160.3	16	31.8	47.7	1.5
70	177.8	109.5	96.8	19.6	92.1	93.6	98.4	127.0	160.3	16	31.8	47.7	1.5
75	190.5	125.4	108.0	19.6	98.5	100.0	108.0	142.9	173.0	16	31.8	47.7	1.5
80	190.5	125.4	108.0	19.6	101.6	103.1	111.1	142.9	173.0	16	31.8	47.7	1.5
85	203.2	135.0	117.5	19.6	108.0	109.5	117.5	155.6	182.5	20	31.8	47.7	1.5
90	215.9	150.8	127.0	19.6	114.3	115.8	127.0	171.5	195.2	20	31.8	47.7	1.5
95	215.9	150.8	127.0	19.6	117.5	119.0	130.2	171.5	195.2	20	31.8	47.7	1.5
100	228.6	168.3	136.5	19.6	123.9	125.4	139.7	188.9	208.0	20	31.8	47.7	1.5
105	228.6	168.3	136.5	19.6	130.1	131.6	149.2	188.9	208.0	20	31.8	47.7	1.5
110	241.3	177.8	146.1	19.6	136.5	138.0	158.8	198.4	220.2	20	31.8	47.7	1.5
115	254.0	186.6	155.8	19.6	142.9	144.4	168.3	211.1	230.2	22	31.8	47.7	1.5
120	254.0	186.6	155.8	19.6	142.9	144.4	168.3	211.1	230.2	22	31.8	47.7	1.5
125	254.0	186.6	155.8	19.6	149.2	150.7	168.3	211.1	230.2	22	31.8	47.7	1.5

Seal sizes from 130mm to 300mm are designed to suit specific equipment using modular components. Contact AESSEAL® technical department for dimensional information and availability.

† = F Min + K Max

CSM™ - Emissions Graph

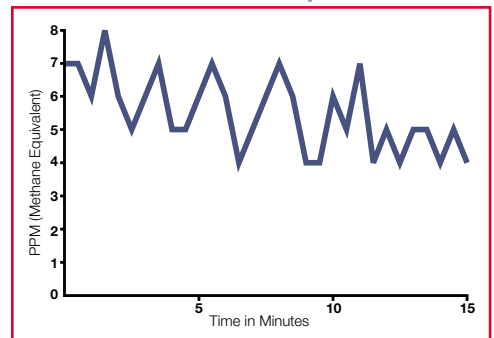

The graph above shows emissions (in PPM methane equivalent) on day 21, the final 15 minutes of testing for a CSM™ - 60mm - Carbon / Silicon Carbide faces.

Excessive radial shaft movement, combined with high rotation speeds and/or adverse fluid characteristics, may compromise the 'leak-free' sealing ability of any mechanical seal.

CDM™ - Cartridge Double for Mixers

The AESSEAL® CDM™ is available in a wide range of seal face, elastomer and alloy combinations, to suit individual applications.

Double cartridge seal for mixers / agitators.



CDM™ - Dimensional Information (inches)

A	B	C	D	E	Min	F	Max	G	Max	H	I	J	K	Max
1.000	4.125	2.125	1.937	0.519	1.625	1.665	1.937	2.687	3.562	1/2	1.281	2.062	0.040	
1.125	4.250	2.250	2.063	0.519	1.750	1.790	2.062	2.812	3.687	1/2	1.281	2.062	0.040	
1.250	4.375	2.375	2.187	0.519	1.875	1.915	2.187	2.937	3.812	1/2	1.281	2.062	0.040	
1.375	4.375	2.500	2.312	0.519	2.000	2.040	2.250	3.062	3.812	1/2	1.281	2.062	0.040	
1.500	5.000	2.812	2.562	0.644	2.250	2.290	2.375	3.375	4.437	1/2	1.312	2.125	0.040	
1.625	5.000	2.812	2.562	0.644	2.375	2.415	2.500	3.375	4.437	1/2	1.312	2.125	0.040	
1.750	5.500	3.187	2.812	0.644	2.500	2.540	2.750	3.750	4.937	1/2	1.312	2.125	0.040	
1.875	5.500	3.187	2.812	0.644	2.625	2.665	2.875	3.750	4.937	1/2	1.312	2.125	0.040	
2.000	6.000	3.562	3.063	0.644	2.750	2.790	3.000	4.125	5.437	1/2	1.380	2.125	0.040	
2.000-AC	5.250	3.450	3.035	0.644	2.750	2.790	3.000	4.000	4.750	1/2	1.380	2.125	0.040	
2.125	6.000	3.562	3.063	0.644	2.875	2.915	3.125	4.125	5.437	1/2	1.380	2.125	0.040	
2.250	6.500	3.812	3.312	0.644	3.000	3.040	3.250	4.500	5.812	5/8	1.380	2.125	0.040	
2.375	6.500	3.812	3.312	0.644	3.125	3.165	3.375	4.500	5.812	5/8	1.380	2.125	0.040	
2.500	7.000	4.312	3.812	0.769	3.375	3.435	3.625	5.000	6.312	5/8	1.500	2.375	0.060	
2.625	7.000	4.312	3.812	0.769	3.500	3.560	3.750	5.000	6.312	5/8	1.500	2.375	0.060	
2.750	7.000	4.312	3.812	0.769	3.625	3.685	3.875	5.000	6.312	5/8	1.500	2.375	0.060	
2.875	7.500	4.937	4.250	0.769	3.750	3.810	4.125	5.625	6.812	5/8	1.500	2.375	0.060	
3.000	7.500	4.937	4.250	0.769	3.875	3.935	4.250	5.625	6.812	5/8	1.500	2.375	0.060	
3.125	7.500	4.937	4.250	0.769	4.000	4.060	4.375	5.625	6.812	5/8	1.500	2.375	0.060	
3.250	8.000	5.312	4.625	0.769	4.125	4.185	4.500	6.125	7.187	3/4	1.500	2.375	0.060	
3.375	8.000	5.312	4.625	0.769	4.250	4.310	4.625	6.125	7.187	3/4	1.500	2.375	0.060	
3.500	8.000	5.312	4.625	0.769	4.375	4.435	4.750	6.125	7.187	3/4	1.500	2.375	0.060	
3.625	8.500	5.937	5.000	0.769	4.500	4.560	5.000	6.750	7.687	3/4	1.500	2.375	0.060	
3.750	8.500	5.937	5.000	0.769	4.625	4.685	5.125	6.750	7.687	3/4	1.500	2.375	0.060	
3.875	8.500	5.937	5.000	0.769	4.750	4.810	5.250	6.750	7.687	3/4	1.500	2.375	0.060	
4.000	9.000	6.625	5.375	0.769	4.875	4.935	5.500	7.437	8.187	3/4	1.500	2.375	0.060	
4.125	9.000	6.625	5.375	0.769	5.125	5.185	5.875	7.437	8.187	3/4	1.500	2.375	0.060	
4.250	9.000	6.625	5.375	0.769	5.125	5.185	5.875	7.437	8.187	3/4	1.500	2.375	0.060	
4.375	9.500	7.000	5.750	0.769	5.375	5.435	6.250	7.812	8.687	3/4	1.500	2.375	0.060	
4.500	9.500	7.000	5.750	0.769	5.375	5.435	6.250	7.812	8.687	3/4	1.500	2.375	0.060	
4.625	10.000	7.345	6.125	0.769	5.625	5.685	6.625	8.312	9.062	7/8	1.500	2.375	0.060	
4.750	10.000	7.345	6.125	0.769	5.625	5.685	6.625	8.312	9.062	7/8	1.500	2.375	0.060	
4.875	10.000	7.345	6.125	0.769	5.875	5.935	6.625	8.312	9.062	7/8	1.500	2.375	0.060	
5.000	10.000	7.345	6.125	0.769	5.875	5.935	6.625	8.312	9.062	7/8	1.500	2.375	0.060	

Seal sizes from 5.125" to 12.000" are designed to suit specific equipment using modular components. Contact AESSEAL® technical department for dimensional information and availability.

† = F Min + K Max

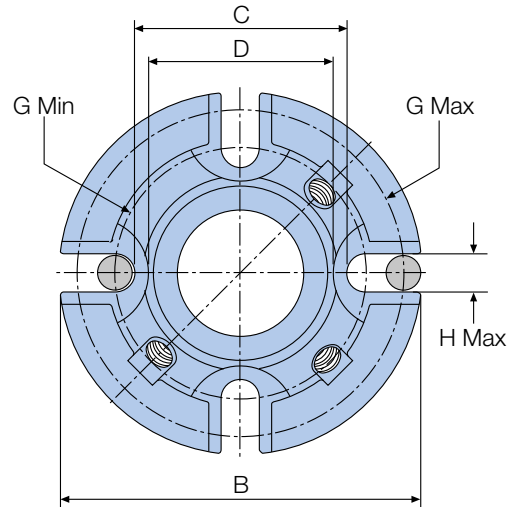

See back page for support systems available.

CDM™ - Dimensional Information (mm)

A	B	C	D	E	Min	F	Max	G	Max	H	I	J	K	Max
24	104.8	54.0	49.2	13.2	40.0	41.0	46.0	67.0	90.5	12	32.5	52.4	1.0	
25	104.8	54.0	49.2	13.2	41.0	42.0	49.0	67.0	90.5	12	32.5	52.4	1.0	
28	108.0	57.2	52.4	13.2	44.0	45.0	52.3	70.3	93.6	12	32.5	52.4	1.0	
30	111.0	60.4	55.6	13.2	46.0	47.0	55.5	73.5	96.8	12	32.5	52.4	1.0	
32	111.0	60.4	55.6	13.2	48.0	49.0	55.5	73.5	96.8	12	32.5	52.4	1.0	
33	111.0	60.4	55.6	13.2	49.0	50.0	55.5	73.5	96.8	12	32.5	52.4	1.0	
35	111.0	63.5	58.8	13.2	51.0	52.0	57.5	76.6	96.8	12	32.5	52.4	1.0	
38	127.0	71.5	65.0	16.4	57.2	58.2	60.3	85.7	114.3	12	33.3	54.0	1.0	
40	127.0	71.5	65.0	16.4	58.0	59.0	60.4	85.7	114.3	12	33.3	54.0	1.0	
43	127.0	71.5	65.0	16.4	61.0	62.0	63.5	85.7	114.3	12	33.3	54.0	1.0	
45	139.7	81.0	71.4	16.4	63.5	64.5	69.9	95.3	127.0	12	33.3	54.0	1.0	
48	139.7	81.0	71.4	16.4	66.7	67.7	73.0	95.3	127.0	12	33.3	54.0	1.0	
50	139.7	81.0	71.4	16.4	68.0	69.0	73.0	95.3	127.0	12	33.3	54.0	1.0	
53	152.4	90.5	77.8	16.4	71.0	72.0	76.2	104.8	139.7	12	35.0	54.0	1.0	
55	152.4	90.5	77.8	16.4	74.0	75.0	79.4	104.8	139.7	12	35.0	54.0	1.0	
58	165.1	96.8	84.1	16.4	76.2	77.2	82.5	114.3	149.2	16	35.0	54.0	1.0	
60	165.1	96.8	84.1	16.4	79.4	80.4	85.7	114.3	149.2	16	35.0	54.0	1.0	
63	177.8	109.5	96.8	19.6	85.8	87.3	92.1	127.0	160.3	16	38.1	60.3	1.5	
65	177.8	109.5	96.8	19.6	88.9	90.4	95.3	127.0	160.3	16	38.1	60.3	1.5	
68	177.8	109.5	96.8	19.6	92.1	93.6	98.4	127.0	160.3	16	38.1	60.3	1.5	
70	177.8	109.5	96.8	19.6	92.1	93.6	98.4	127.0	160.3	16	38.1	60.3	1.5	
75	190.5	125.4	108.0	19.6	98.5	100.0	108.0	142.9	173.0	16	38.1	60.3	1.5	
80	190.5	125.4	108.0	19.6	101.6	103.1	111.1	142.9	173.0	16	38.1	60.3	1.5	
85	203.2	135.0	117.5	19.6	108.0	109.5	117.5	155.6	182.5	20	38.1	60.3	1.5	
90	215.9	150.8	127.0	19.6	114.3	115.8	127.0	171.5	195.2	20	38.1	60.3	1.5	
95	215.9	150.8	127.0	19.6	117.5	119.0	130.2	171.5	195.2	20	38.1	60.3	1.5	
100	228.6	168.3	136.5	19.6	123.9	125.4	139.7	188.9	208.0	20	38.1	60.3	1.5	
105	228.6	168.3	136.5	19.6	130.1	131.6	149.2	188.9	208.0	20	38.1	60.3	1.5	
110	241.3	177.8	146.1	19.6	136.5	138.0	158.8	198.4	220.6	20	38.1	60.3	1.5	
115	254.0	186.6	155.8	19.6	142.9	144.4	168.3	211.1	230.2	22	38.1	60.3	1.5	
120	254.0	186.6	155.8	19.6	142.9	144.4	168.3	211.1	230.2	22	38.1	60.3	1.5	
125	254.0	186.6	155.8	19.6	149.2	150.7	168.3	211.1	230.2	22	38.1	60.3	1.5	

Seal sizes from 130mm to 300mm are designed to suit specific equipment using modular components. Contact AESSEAL® technical department for dimensional information and availability.

† = F Min + K Max

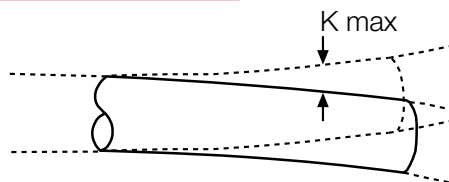
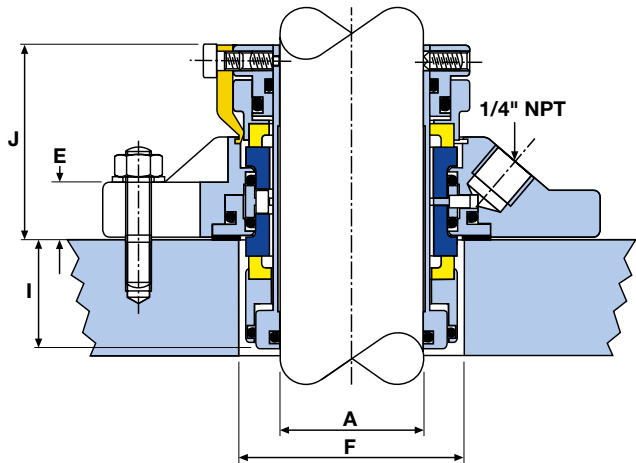

K Max = Maximum TOTAL Radial Movement

DMSC™ – Double Monolithic Stationary Convection

Double Cartridge seal for mixers used where a larger barrier differential pressure is required.

The DMSC™ seal design was created as a result of a request from a major AESSEAL® customer who required a seal design features which was not satisfied by one existing AESSEAL® product. New and novel patented features were developed, helping to ensure that the final product would excel in some of the most difficult and arduous applications found on-site



Features:

- Monolithic seal faces provide maximum face stability in high temperature applications.
- Seal face drive over large contact area prevents damage to faces in stop / start applications.
- large 3/8" NPT seal gland ports maximize cooling potential and extend seal life
- Hydraulically balanced seal-face technology for reduced power consumption with the ability to withstand pressure fluctuations
- Stationary design is suitable for high speed applications
- Sizes available from 1.000" to 5.000" (24mm - 125mm)

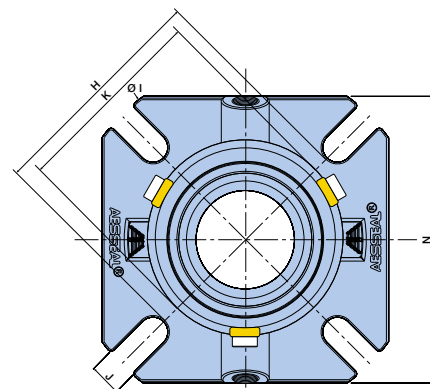
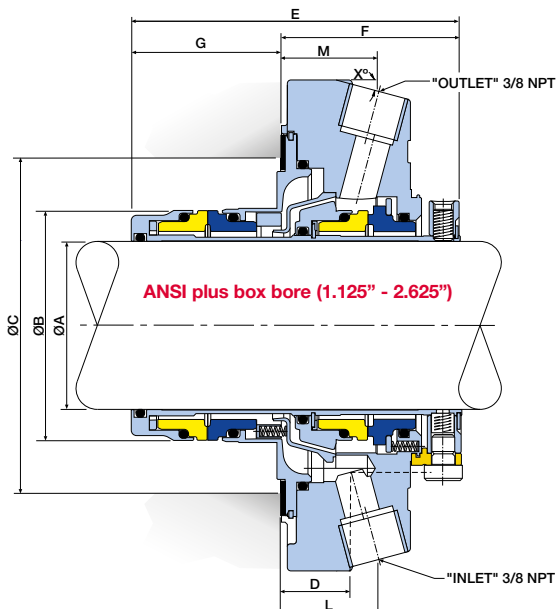
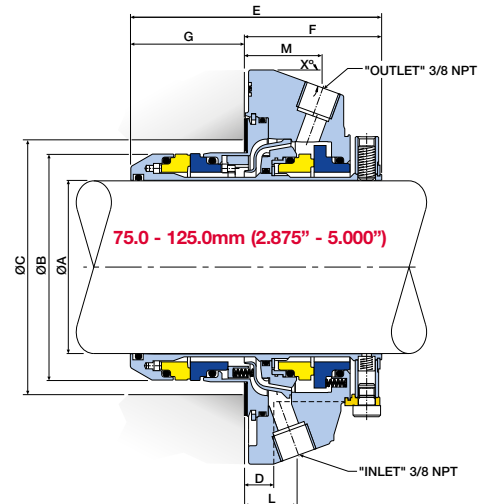
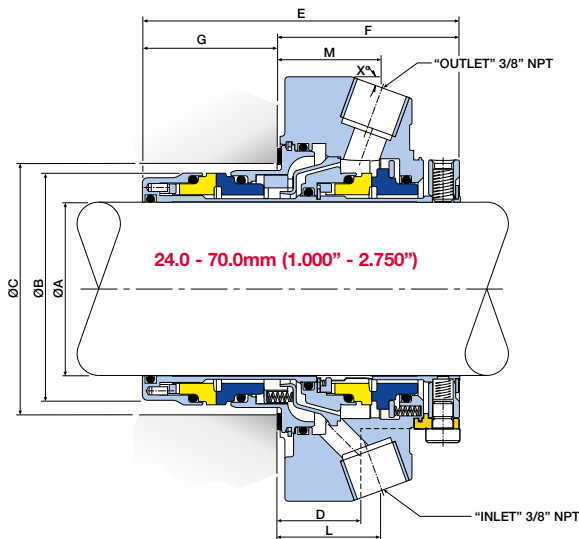

Standard ISO / ANSI box bore gland format

DMSC™ Standard ISO / ANSI Box Bore 24.0mm - 70mm (1.000" - 2.750")

Seal Size	ØA	ØB	ØC		D	E	F	G	H	ØI	J	K	L	M	N	X°
			Min	Max												
24.0	24.0	40.8	43.0	48.0	19.2	92.0	53.1	38.9	57.7	105.0	14.0	50.4	28.2	29.2	99.0	20°
25.0	25.0	41.8	44.0	51.0	19.2	92.0	53.1	38.9	62.0	105.0	14.0	51.0	27.8	29.2	99.0	20°
28.0	28.0	45.4	47.0	54.0	19.2	92.0	53.1	38.9	65.0	111.0	14.0	55.5	27.5	29.4	101.6	20°
30.0	30.0	46.8	49.0	54.0	19.2	92.0	53.1	38.9	64.6	105.0	14.0	56.4	27.4	29.7	97.8	20°
32.0	32.0	49.8	51.0	57.0	21.5	92.0	53.1	38.9	66.5	105.0	14.0	59.4	28.4	30.9	99.0	25°
33.0	33.0	49.8	51.0	57.0	21.5	92.0	53.1	38.9	66.5	105.0	14.0	59.4	28.4	30.9	99.0	25°
35.0	35.0	51.8	53.0	59.0	20.7	92.0	53.1	38.9	68.5	120.0	14.0	61.4	29.3	29.3	104.1	15°
38.0	38.0	55.7	57.0	69.9	21.3	92.0	53.1	38.9	80.7	135.0	14.0	70.8	30.1	30.1	114.3	20°
40.0	40.0	57.6	59.0	70.5	21.3	93.2	53.1	40.1	80.7	135.0	14.0	70.8	30.1	30.1	114.3	20°
43.0	43.0	58.6	61.0	70.5	21.3	93.2	53.1	40.1	80.7	135.0	14.0	70.8	26.7	29.8	114.3	15°
45.0	45.0	62.0	64.0	75.0	21.9	93.2	53.1	40.1	84.6	139.0	14.0	73.8	30.5	30.5	117.5	20°
48.0	48.0	65.2	66.6	74.6	21.3	93.2	53.1	40.1	83.7	139.0	14.0	75.7	29.3	29.9	117.5	20°
50.0	50.0	68.0	70.0	78.0	21.6	93.2	53.1	40.1	87.6	150.0	17.5	78.9	30.5	30.5	124.5	20°
53.0	53.0	71.6	73.0	87.0	21.3	93.2	53.1	40.1	97.0	150.0	17.5	85.0	25.7	29.5	136.5	15°
55.0	55.0	71.6	73.0	87.0	21.3	93.2	53.1	40.1	97.0	150.0	17.5	85.0	25.7	29.5	136.5	15°
58.0	58.0	74.7	76.2	92.0	21.3	93.2	53.1	40.1	102.4	150.0	17.5	88.0	30.1	30.1	139.7	20°
60.0	60.0	77.9	80.0	92.0	21.6	93.2	53.1	40.1	102.4	164.5	17.5	88.0	30.5	30.5	139.7	20°
63.0	63.0	81.1	83.0	98.5	21.6	93.2	53.1	40.1	108.7	171.0	17.5	94.4	29.8	29.8	147.3	15°
65.0	65.0	84.3	86.0	98.5	21.3	93.2	53.1	40.1	108.7	171.0	17.5	94.4	29.4	29.4	147.3	15°
70.0	70.0	87.4	89.0	100.0	21.3	93.2	53.1	40.1	112.0	180.5	17.5	98.3	29.7	29.7	152.4	20°
1.000	1.000	1.646	1.750	2.000	0.755	3.622	2.091	1.531	2.441	4.134	0.551	2.008	1.093	1.150	3.900	20°
1.125	1.125	1.786	1.875	2.125	0.755	3.622	2.091	1.531	2.559	4.375	0.551	2.183	1.084	1.159	4.000	20°
1.250	1.250	1.961	2.000	2.250	0.847	3.622	2.091	1.531	2.618	4.134	0.551	2.340	1.120	1.215	3.900	25°
1.375	1.375	2.040	2.125	2.312	0.815	3.622	2.091	1.531	2.697	4.725	0.551	2.418	1.154	1.154	4.100	15°
1.500	1.500	2.192	2.250	2.750	0.837	3.622	2.091	1.531	3.177	5.315	0.551	2.786	1.185	1.185	4.500	20°
1.625	1.625	2.317	2.375	2.750	0.841	3.671	2.091	1.580	3.177	5.315	0.551	2.786	1.052	1.173	4.500	15°
1.750	1.750	2.442	2.500	2.937	0.862	3.671	2.091	1.580	3.337	5.475	0.551	2.907	1.200	1.200	4.625	20°
1.875	1.875	2.567	2.625	2.937	0.837	3.671	2.091	1.580	3.297	5.475	0.551	2.982	1.152	1.175	4.625	20°
2.000	2.000	2.677	2.750	3.062	0.852	3.671	2.091	1.580	3.450	5.906	0.689	3.108	1.200	1.200	4.900	20°
2.125	2.125	2.817	2.875	3.437	0.840	3.671	2.091	1.580	3.819	5.906	0.689	3.346	1.013	1.163	5.375	15°
2.250	2.250	2.942	3.000	3.625	0.837	3.671	2.091	1.580	4.030	6.475	0.689	3.466	1.185	1.185	5.500	20°
2.375	2.375	3.067	3.125	3.625	0.852	3.671	2.091	1.580	4.030	6.475	0.689	3.466	1.200	1.200	5.500	20°
2.500	2.500	3.192	3.250	3.875	0.852	3.671	2.091	1.580	4.280	6.725	0.689	3.716	1.173	1.173	5.800	15°
2.625	2.625	3.317	3.375	3.875	0.837	3.671	2.091	1.580	4.280	6.725	0.689	3.716	1.158	1.158	5.800	15°
2.750	2.750	3.442	3.500	3.937	0.837	3.671	2.091	1.580	4.405	7.100	0.689	3.871	1.171	1.171	6.000	20°



DMSC™ Standard ISO / ANSI Box Bore 75.0mm - 125mm (2.875" - 5.000")

Seal Size	ØA	ØB	ØC		D	E	F	G	H	ØI	J	K	L	M	N	X°
			Min	Max												
75.0	75.0	98.0	101.6	117.5	25.8	115.9	63.5	52.4	131.4	189.3	17.5	116.5	25.0	36.3	169.4	20°
80.0	80.0	104.4	108.0	127.0	25.8	115.9	63.5	52.4	142.5	201.9	21.0	126.0	25.0	36.3	169.4	20°
85.0	85.0	107.6	111.1	127.0	25.8	115.9	63.5	52.4	142.5	201.9	21.0	126.0	25.0	36.3	182.1	20°
90.0	90.0	113.9	117.5	136.5	25.8	115.9	63.5	52.4	152.0	214.6	21.0	135.5	26.2	36.3	194.8	20°
95.0	95.0	117.1	120.0	136.5	25.8	115.9	63.5	52.4	152.0	214.6	21.0	135.5	26.2	36.3	194.8	20°
100.0	100.0	123.4	127.0	139.7	25.8	115.9	63.5	52.4	155.2	227.3	21.0	138.7	26.2	36.3	207.5	20°
105.0	105.0	129.8	133.4	152.4	23.8	115.9	63.5	52.4	167.9	240.0	21.0	151.4	36.0	40.1	-	45°
110.0	110.0	136.1	139.7	152.4	23.8	115.9	63.5	52.4	167.9	240.0	21.0	151.4	36.0	40.1	-	45°
115.0	115.0	142.5	146.1	165.1	23.8	115.9	63.5	52.4	180.6	252.7	24.0	164.1	36.0	40.1	-	45°
120.0	120.0	142.5	146.1	165.1	23.8	115.9	63.5	52.4	180.6	252.7	24.0	164.1	36.0	40.1	-	45°
125.0	125.0	148.8	152.4	165.1	23.8	115.9	63.5	52.4	180.6	252.7	24.0	164.1	36.0	40.1	-	45°
2.875	2.875	3.735	3.875	4.625	1.014	4.562	2.500	2.062	5.173	7.450	0.689	4.585	0.986	1.429	6.670	20°
3.000	3.000	3.860	4.000	4.625	1.014	4.562	2.500	2.062	5.173	7.450	0.689	4.585	0.986	1.429	6.670	20°
3.125	3.125	3.985	4.125	4.625	1.014	4.562	2.500	2.062	5.173	7.450	0.689	4.585	0.986	1.429	6.670	20°
3.250	3.250	4.110	4.250	5.000	1.014	4.562	2.500	2.062	5.610	7.950	0.827	4.960	0.986	1.429	7.170	20°
3.375	3.375	4.235	4.375	5.000	1.014	4.562	2.500	2.062	5.610	7.950	0.827	4.960	0.986	1.429	7.170	20°
3.500	3.500	4.360	4.500	5.000	1.014	4.562	2.500	2.062	5.610	7.950	0.827	4.960	0.986	1.429	7.170	20°
3.625	3.625	4.485	4.625	5.375	1.014	4.562	2.500	2.062	5.985	8.450	0.827	5.335	1.033	1.429	7.670	20°
3.750	3.750	4.610	4.750	5.375	1.014	4.562	2.500	2.062	5.985	8.450	0.827	5.335	1.033	1.429	7.670	20°
3.875	3.875	4.860	5.000	5.500	1.014	4.562	2.500	2.062	6.110	8.950	0.827	5.460	1.033	1.429	8.170	20°
4.000	4.000	4.860	5.000	5.500	1.014	4.562	2.500	2.062	6.110	8.950	0.827	5.460	1.033	1.429	8.170	20°
4.125	4.125	5.110	5.250	6.000	0.937	4.562	2.500	2.062	6.610	9.450	0.827	5.960	1.418	1.578	-	45°
4.250	4.250	5.110	5.250	6.000	0.937	4.562	2.500	2.062	6.610	9.450	0.827	5.960	1.418	1.578	-	45°
4.375	4.375	5.360	5.500	6.000	0.937	4.562	2.500	2.062	6.610	9.450	0.827	5.960	1.418	1.578	-	45°
4.500	4.500	5.360	5.500	6.000	0.937	4.562	2.500	2.062	6.610	9.450	0.827	5.960	1.418	1.578	-	45°
4.625	4.625	5.610	5.750	6.500	0.937	4.562	2.500	2.062	7.110	9.950	0.945	6.460	1.418	1.578	-	45°
4.750	4.750	5.610	5.750	6.500	0.937	4.562	2.500	2.062	7.110	9.950	0.945	6.460	1.418	1.578	-	45°
4.875	4.875	5.860	6.000	6.500	0.937	4.562	2.500	2.062	7.110	9.950	0.945	6.460	1.418	1.578	-	45°
5.000	5.000	5.860	6.000	6.500	0.937	4.562	2.500	2.062	7.110	9.950	0.945	6.460	1.418	1.578	-	45°

With the exception of 5.500", seal sizes from 130mm - 150mm (5.125" - 6.000") are designed to suit specific equipment using modular components. Contact AESSEAL® technical department for dimensional information and availability.

For sizes above 5.000" / 125mm please contact the AESSEAL® technical department.

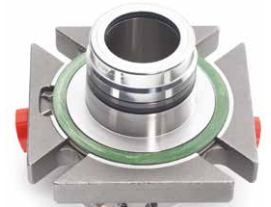

DMSC™ Medium Box Bore

Seal Size	ØA	ØB	ØC		D	E	F	G	H	ØI	J	K	L	M	N	X°
			Min	Max												
35.0-M	35.0	51.8	53.0	65.0	20.6	92.0	53.1	38.9	87.6	136.5	14.0	64.7	18.9	27.3	108.0	15°
1.125-M	1.125	1.786	1.875	2.250	0.800	3.622	2.091	1.531	3.199	5.000	0.551	2.323	0.926	1.141	3.990	15°
1.375-M	1.375	2.040	2.125	2.500	0.750	3.622	2.091	1.531	3.449	5.375	0.551	2.549	0.950	1.141	4	

SCMS™ Short Canister Mixer Seal

Designed specifically for Mixer, Agitator and Reactor applications.

Available from 30mm to 220mm (1.250" to 8.625")



- Double and Single Seal for both modern and mature mixer designs
- Suitable for both top or side entry applications
- Reduced height - ideal in situations where space is limited
- Dual Balanced Design - maintains containment through a range of process fluctuations
- Fail safe protection - Independent seal face loading using unique common multi-spring design (Patent Pending)
- Accommodates up to 3.5mm of radial (T.I.R.) movement (size dependant)
- Self Adjusting Axial Movement Compensation - common multi-spring design maintains precise face loading to both sets of seal faces (Double Seal Only)
- Monolithic seal faces (Double Seal Only)
- Available with optional modular bearing assembly
- Optional water cooled mounting flange to extend ATEX limits
- Engineered solutions available
- Certifications Available:
 - ATEX Zone 0/20, 1/21 & 2/22
 - FDA Compliant materials

SCMS™ – Short Canister Mixer Seal Wet or Dry Contacting Version

The SCMS™ Mixer seal is specifically designed for use on a broad range of mixers, agitators and reactor applications. It is suitable for side entry (flooded) or top entry (running in vapour) mounting. The modular SCMS™ design facilitates both wet and dry running versions.

SCMS - W seal is a traditional wet seal arrangement intended for use with a API Plan 53A or 54 seal support system

SCMS - D is a dry running contacting configuration intended for use with a API Plan 74 seal support system



SCMS™ ATEX Zone 0
(shown with Taper Lock Clamp Ring option)



FEA Optimized seal face for
stable dry running

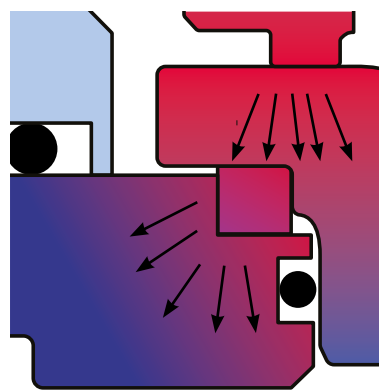

Conductive wedges used to assist
heat dissipation

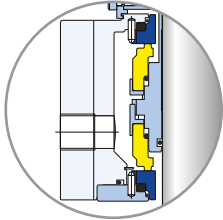

SCMS™ 30mm - 40mm
(1.125" to 1.500")

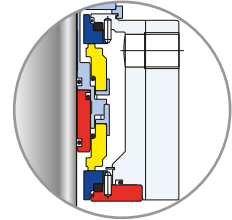

SCMS™ 30mm - 40mm
(1.125" to 1.500")

SCMS™ 50mm - 125mm
(2.000" to 5.000")

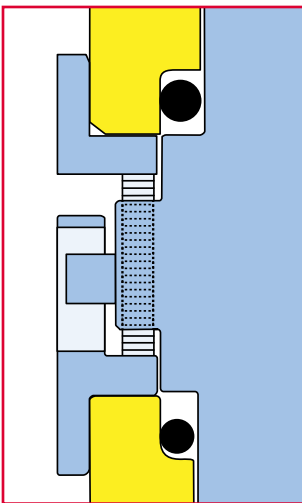
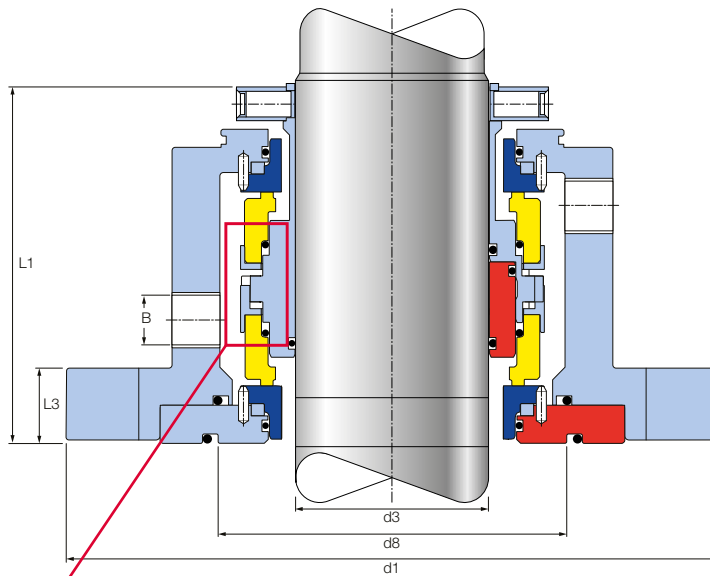

Independent seal face loading using
common multi-spring design

Face Options

Inboard

Resin Impregnated Carbon / SiC, SiC / SiC (SCMS-W)
Dry Running Carbon / SiC (SCMS-D)

Outboard

Resin Impregnated Carbon / SiC, (SCMS-W)
Dry Running Carbon / SiC (SCMS-D)

Elastomer options

Viton (Standard), EPDM, Aflas, Kalrez

Gasket options

O'Ring (standard), AF1, GFT

Shaft clamping

Clamp ring with set screws (standard)

Options

Taper lock clamp ring, Exotic product-wetted
metallurgy, Water cooled mounting flange

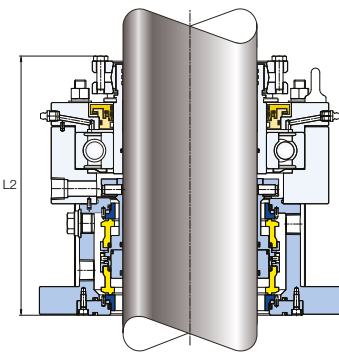

Optional modular bearing
assembly

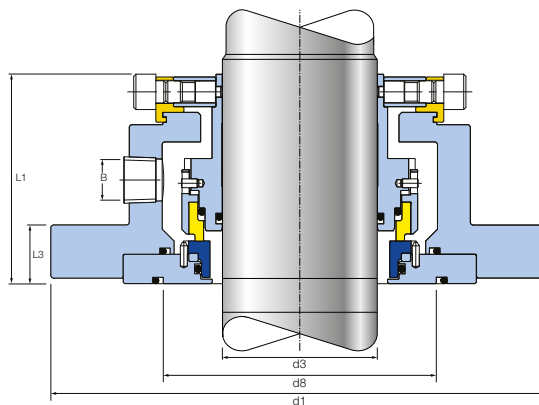

SCMS™ single seal option

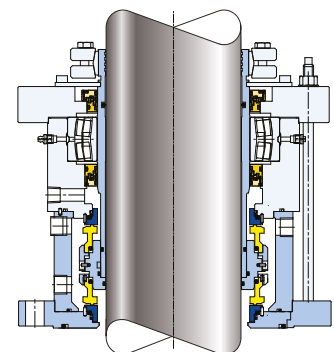

160mm-220mm
(6.250" to 8.625")

SCMS™ - Double Seal Dimensional Information

d3	d1	Øk	Øh	L1	L2	L3	d8	B	Max Bolt	K Max
30mm	125.5	106.5-116.5	12	102	187	87	63	3/8NPT	M10	2
40mm	135	116-125	12	102	187	87	70	3/8NPT	M10	2
50mm	189	162-173	17.5	117	204	26.5	95	3/8NPT	M16	3
60mm	202	171-186	17.5	117	206	26.5	105	3/8NPT	M16	3
70mm	225	191-209	17.5	136	230	26.5	120	1/2NPT	M16	3.5
80mm	235	203-219	17.5	136	240	26.5	130	1/2NPT	M16	3.5
90mm	250	221-231	22	136	245	26.5	143	1/2NPT	M20	3.5
100mm	265	231-245	22	136	254	26.5	152	1/2NPT	M20	3.5
125mm	291	256-271	22	136	258	28	177	1/2NPT	M20	3.5
140mm	315	277-295	22	145	276	30	197	1/2NPT	M20	3.5
160mm	366	327	23 x 8	172	340	32	245	1/2NPT	M20	4
180mm	379	340	23 x 8	172	360	32	257	1/2NPT	M20	4
200mm	398	359	23 x 12	172	360	32	270	1/2NPT	M20	4
220mm	418	378	23 x 12	172	360	32	295	1/2NPT	M20	4
1.250"	4.94	4.193-4.587	0.472	4.020	7.360	3.420	2.500	3/8NPT	3/8"	0.080
1.500"	5.320	4.570-4.937	0.472	4.020	7.360	3.420	2.750	3/8NPT	3/8"	0.080
2.000"	7.440	6.183-6.380	0.690	4.600	8.030	1.040	3.740	3/8NPT	5/8"	0.120
2.375"	7.950	6.730-7.310	0.690	4.600	8.110	1.040	4.130	3/8NPT	5/8"	0.120
2.500"	8.370	7.187-7.750	0.690	4.600	8.110	1.040	4.300	3/8NPT	5/8"	0.120
2.750"	8.860	7.520-8.250	0.690	5.350	9.060	1.040	4.720	1/2NPT	5/8"	0.138
3.125"	9.250	8.000-8.630	0.690	5.350	9.450	1.040	5.120	1/2NPT	5/8"	0.138
3.500"	9.840	8.700-9.000	0.870	5.350	9.650	1.040	5.630	1/2NPT	3/4"	0.138
4.000"	10.430	9.090-9.688	0.870	5.350	10.000	1.040	5.980	1/2NPT	3/4"	0.138
5.000"	11.460	10.080-10.688	0.870	5.350	10.160	1.100	6.970	1/2NPT	3/4"	0.138
5.500"	12.400	10.900-11.630	0.870	5.700	10.870	1.180	7.750	1/2NPT	3/4"	0.138
6.250"	14.400	12.880	0.900	6.770	13.380	1.250	9.650	1/2NPT	3/4"	0.157
7.000"	14.900	13.380	0.900	6.770	14.180	1.250	10.120	1/2NPT	3/4"	0.157
7.875"	15.700	14.130	0.900	6.770	14.180	1.250	10.630	1/2NPT	3/4"	0.157
8.625"	16.400	14.880	0.900	6.770	14.180	1.250	11.600	1/2NPT	3/4"	0.157

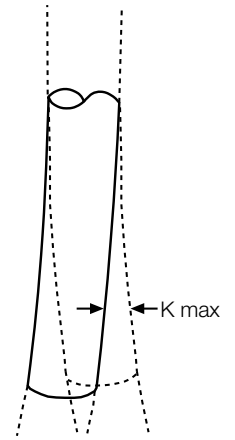

Other sizes available. Contact your nearest AESSEAL® office for availability.

* Large size SCMS™, Sizes 160mm – 220mm (6.250 - 8.625") are designed to order and are not inventoried. Contact AESSEAL® technical department for information and availability.

SCMS™ - Single Seal Dimensional Information

d3	d1	Øk	Øh	L1	L2	L3	d8	B	Max Bolt	K Max
30mm	129	110-119	12	82	170	66.3	63	3/8NPT	M10	2.5
40mm	135	116-125	12	82	170	66.3	70	3/8NPT	M10	3
50mm	189	162-173	17.5	90	177	26.5	95	3/8NPT	M16	4
60mm	202	171-186	17.5	90	179	26.5	105	3/8NPT	M16	4
70mm	225	191-209	17.5	95	187	26.5	120	3/8NPT	M16	4
80mm	235	203-219	17.5	95	200	26.5	130	3/8NPT	M16	4
90mm	250	221-231	22	95	203	26.5	143	3/8NPT	M20	4
100mm	265	231-245	22	95	210	26.5	152	3/8NPT	M20	4
125mm	291	256-271	22	95	218	28	177	3/8NPT	M20	4
140mm	315	277-295	22	111	251	30	197	3/8NPT	M20	4
160mm	366	327	23	172	340	32	245	1/2NPT	M20	4
180mm	379	340	23	172	360	32	257	1/2NPT	M20	4
200mm	398	359	23	172	360	32	270	1/2NPT	M20	4
220mm	418	378	23	172	360	32	295	1/2NPT	M20	4
1.250"	5.080	4.330-4.700	0.472	3.230	6.700	2.618	2.500	3/8NPT	3/8"	0.100
1.500"	5.320	4.570-4.937	0.472	3.230	6.700	2.618	2.750	3/8NPT	3/8"	0.120
2.000"	7.440	6.183-6.380	0.690	3.540	7.000	1.040	3.740	3/8NPT	5/8"	0.157
2.375"	7.950	6.730-7.310	0.690	3.540	7.050	1.040	4.130	3/8NPT	5/8"	0.157
2.500"	8.370	7.187-7.750	0.690	3.540	7.120	1.040	4.300	3/8NPT	5/8"	0.157
2.750"	8.860	7.520-8.250	0.690	3.540	7.360	1.040	4.720	3/8NPT	5/8"	0.157
3.125"	9.250	8.000-8.630	0.690	3.540	7.870	1.040	5.120	3/8NPT	5/8"	0.157
3.500"	9.840	8.700-9.000	0.870	3.540	8.000	1.040	5.630	3/8NPT	3/4"	0.157
4.000"	10.430	9.090-9.688	0.870	3.540	8.270	1.040	5.980	3/8NPT	3/4"	0.157
5.000"	11.460	10.080-10.688	0.870	3.540	8.580	1.100	6.970	3/8NPT	3/4"	0.157
5.500"	12.400	10.900-11.630	0.870	4.370	9.880	1.180	7.750	3/8NPT	3/4"	0.197
6.250"	14.400	12.880	0.900	6.770	13.380	1.250	9.650	1/2NPT	3/4"	0.157
7.000"	14.900	13.380	0.900	6.770	14.180	1.250	10.120	1/2NPT	3/4"	0.157
7.875"	15.700	14.130	0.900	6.770	14.180	1.250	10.630	1/2NPT	3/4"	0.157
8.625"	16.400	14.880	0.900	6.770	14.180	1.250	11.600	1/2NPT	3/4"	0.157

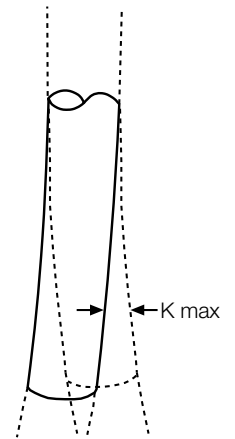

Other sizes available. Contact your nearest AESSEAL® office for availability.

* Large size SCMS™, Sizes 160mm – 220mm (6.250 - 8.625") are designed to order and are not inventoried. Contact AESSEAL® technical department for information and availability.

Mixmaster IV™

The seal range is offered with the following design features:

- Designed for mixers, agitators and reactors
- Double hydraulically balanced seal faces
- Available with non-metallic wetted components
- Cartridge seal with integral load carrying bearing to DIN 28 138 parts 1 and 2
- Available to suit any shaft (within the size range)
- No shaft fretting

Specifications Mixmaster IV™

The Mixmaster IV™ Range of Mixer Seals conform to the following relevant DIN Specifications.

- DIN 28 138 part 1** - Stainless Mixer Seal
- DIN 28 138 part 2** - Glass Lined
- DIN 28 138 part 3** - Screwed Connection Designation & Position
- DIN 28 137 part 2** - Glass Lined Mounting Flanges
- DIN 28 141** - Stainless Steel Mounting Flanges
- DIN 28 154 & 159** - Shaft Dimensions

Environmental Connections

The Mixmaster IV™ connections are positioned in accordance with DIN 28 138 part 3.

MIXMASTER IV™ Load Carrying Capabilities			
ØD3		DIN 28 159 Max Loads	
40mm	(1.500")	1,562 N	351 lbs
50mm	(2.000")	3,468 N	779 lbs
60mm	(2.375")	6,640 N	1,492 lbs
80mm	(3.125")	17,289 N	3,886 lbs
100mm	(4.000")	34,820 N	7,827 lbs
125mm	(5.000")	44,188 N	9,933 lbs
140mm	(5.500")	38,147 N	8,575 lbs
160mm	(6.250")	60,185 N	13,530 lbs

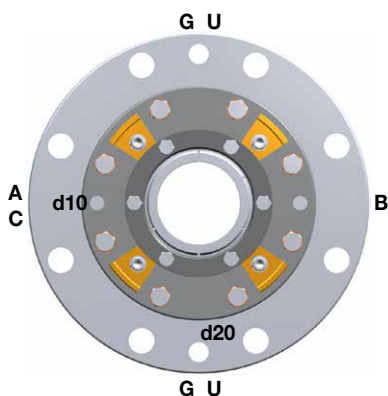

- A = Barrier IN
- B = Barrier OUT
- C = Leakage to Atmosphere
- G = Grease Port
- U = Pressure / Thermometer Port

- d10 = Lifting Threads
- d20 = Jacking Threads



Mixmaster IV-II-BS™

The Mixmaster IV™ is a fully customizable top entry seal designed in accordance with DIN 28 138.

- Top entry seal design
- Double hydraulically balanced inboard seal faces
- Conforms to DIN 28 138 Part 1 and DIN 28 141
- Modular design
- Available to fit any shaft size within the seal range
- Connections positioned in accordance with DIN 28 138 Part 3
- Integral load carrying bearing
- Metallic wetted parts

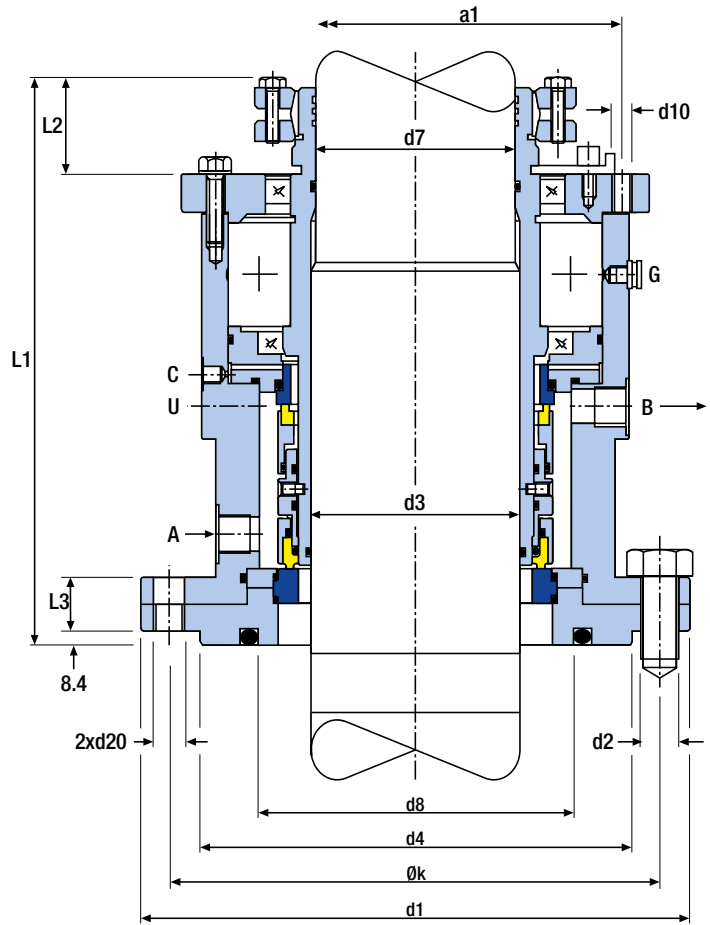

Mixmaster IV-II-BS™ Dimensional Information (inches)

d3	d7	d1	nx d2	d4	d8	Øk	L1	L2	d10	d20	A,B	C	U
1.125" / 1.250" / 1.500"	-	6.890"	4 x 0.750"	4.330"	3.740"	5.710"	8.270"	1.320"	M12	M16	G3/8"	G1/8"	G1/2"
1.750" / 2.000" / 2.250"	-	9.450"	8 x 0.750"	6.930"	4.210"	8.260"	8.860"	1.320"	M12	M16	G3/8"	G1/8"	G1/2"
2.500" / 2.750" / 3.000"	-	10.830"	8 x 0.875"	8.030"	5.910"	9.450"	10.450"	1.770"	M16	M20	G1/2"	G1/8"	G1/2"
3.250" / 3.500" / 3.750" / 4.000"	-	12.000"	8 x 0.875"	9.210"	6.850"	10.630"	10.700"	1.770"	M16	M20	G1/2"	G1/8"	G1/2"
4.250" / 4.500" / 4.750" / 5.000"	-	13.000"	8 x 0.875"	10.240"	7.870"	11.610"	12.300"	1.770"	M20	M20	G1/2"	G1/8"	G1/2"
5.250" / 5.500"	-	15.550"	12 x 0.875"	12.320"	8.620"	13.780"	12.520"	2.050"	M20	M20	G1/2"	G1/8"	G1/2"
5.750" / 6.000" / 6.250"	-	15.550"	12 x 0.875"	12.320"	9.370"	13.780"	13.600"	2.050"	M20	M20	G1/2"	G1/8"	G1/2"

Dimensional information on larger sizes is available on request.

Mixmaster IV-II-BS™ Dimensional Information (mm)

d3	d7	d1	nx d2	d4	d8	Øk	L1	L2	d10	d20	A,B	C	U	L3	a1
30, 33, 35, 38	-	175	4x18	110	95	145	210	33.5	M12	M16	G3/8	G1/8	G1/2	28	109.5
40	38	175	4x18	110	95	145	210	33.5	M12	M16	G3/8	G1/8	G1/2	28	109.5
43, 45, 48	-	240	8x18	176	107	210	215	33.5	M12	M16	G3/8	G1/8	G1/2	28	133
50	48	240	8x18	176	107	210	215	33.5	M12	M16	G3/8	G1/8	G1/2	28	133
53, 55, 58	-	240	8x18	176	121	210	225	33.5	M12	M16	G3/8	G1/8	G1/2	35	146
60	58	240	8x18	176	121	210	225	33.5	M12	M16	G3/8	G1/8	G1/2	35	146
63, 65, 68, 70, 75	-	275	8x22	204	150	240	265	45	M16	M20	G1/2	G1/8	G1/2	40	190
80	78	275	8x22	204	150	240	265	45	M16	M20	G1/2	G1/8	G1/2	40	190
85, 90, 95	-	305	8x22	234	174	270	270	45	M16	M20	G1/2	G1/8	G1/2	40	220
100	98	305	8x22	234	174	270	270	45	M16	M20	G1/2	G1/8	G1/2	40	220
105, 110, 115, 120	-	330	8x22	260	200	295	312	45	M20	M20	G1/2	G1/8	G1/2	40	249
125	120	330	8x22	260	200	295	312	45	M20	M20	G1/2	G1/8	G1/2	40	249
130, 135	-	395	12x22	313	219	350	318	52	M20	M20	G1/2	G1/8	G1/2	22	264
140	135	395	12x22	313	219	350	318	52	M20	M20	G1/2	G1/8	G1/2	22	264
145, 150, 155	-	395	12x22	313	219	350	318	52	M20	M20	G1/2	G1/8	G1/2	44	304
160	150	395	12x22	313	238	350	345	52	M20	M20	G1/2	G1/8	G1/2	44	304

Dimensional information on larger sizes is available on request.

Mixmaster IV-II-BG™ Glass (Enamel) Lined



- Top entry seal design
- All wetted parts are non-metallic
- Double hydraulically balanced inboard seal faces
- Conforms to DIN 28 138 Part 2 and DIN 28 137 Part 2
- Modular design
- Available to fit any shaft size within the seal range
- Connections positioned in accordance with DIN 28 138 Part 3
- Designed to order with exotic alloy wetted materials including Alloy C276 / Titanium / Alloy 20
- The flange can be designed to suit customer specific equipment

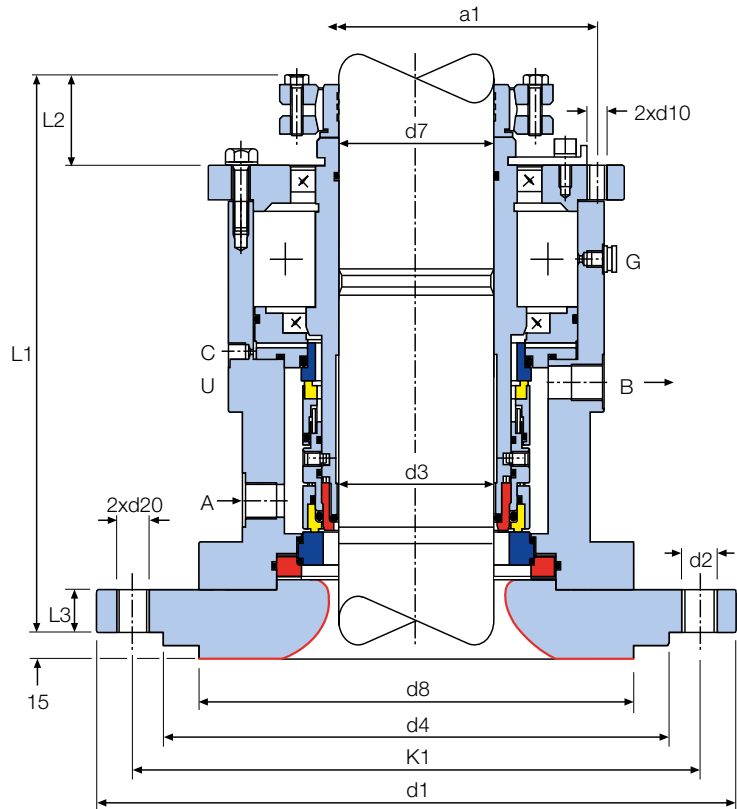

Flanges Nominal Diameters E700-E901

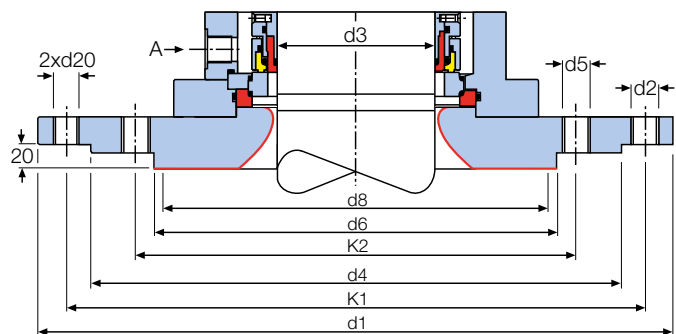

Mixmaster IV-II-BG™ Dimensional Information (mm)

d3	d7	d1	nx d2	d4	nx d5	d6	d8	d10	d20	a1	L1	K1	K2	L3	L2	A,B	C	U	NFD
40	38	175	4x18	110	-	-	138	M12	M16	110	226	145	-	20	33.5	G3/8	G1/8	G1/2	E125
50	48	240	8x18	176	-	-	138	M12	M16	133	226	210	-	20	33.5	G3/8	G1/8	G1/2	E200
60	58	275	8x22	204	-	-	188	M12	M20	146	234	240	-	22	33.5	G3/8	G1/8	G1/2	E250
80	78	305	8x22	234	-	-	212	M16	M20	190	275	270	-	25	45	G1/2	G1/8	G1/2	E300
100	98	395	12x22	313	-	-	268	M16	M20	200	282	350	-	25	45	G1/2	G1/8	G1/2	E500
125	120	505	4x22	422	12x22	320	306	M20	M20	249	323	460	350	22	52	G1/2	G1/8	G1/2	E700
140	135	505	4x22	422	12x22	320	306	M20	M20	264	331	460	350	22	52	G1/2	G1/8	G1/2	E700
160	150	505	4x22	422	12x22	320	306	M20	M20	304	355	460	350	22	52	G1/2	G1/8	G1/2	E900
160*	150	565	4x26	474	12x22	370	356	M20	M20	304	355	515	400	22	52	G1/2	G1/8	G1/2	E901

Dimensional information on larger sizes is available on request.

* Nominal size 161

Mixmaster V™ – Internal Balanced Mechanical Seal

The Mixmaster V™ is a value for money, modular design with balanced seal faces and an integral load carrying bearing.

The seal is designed in accordance with DIN 28 138. The Mixmaster V™ is a standard design which cannot be customized.



The seal is offered with the following features:

- Top entry seal design
- Designed for mixers, agitators and reactors
- Balanced seal faces for the barrier fluid (Mixmaster V™)
- Cartridge seal with integral load carrying bearing to DIN 28 159
- No shaft fretting
- Modular design
- Seal faces remain closed in reverse pressure conditions

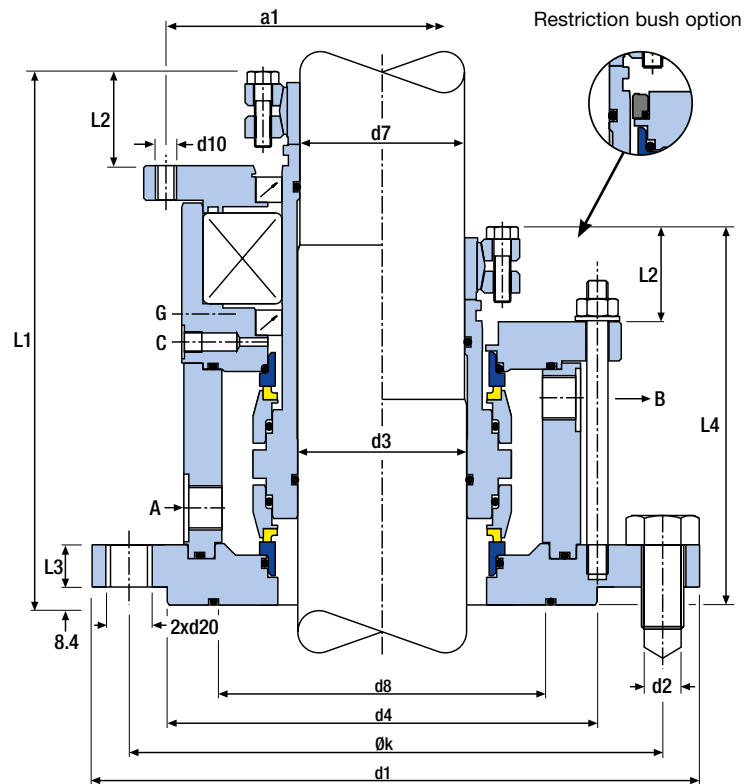

NOTE: The mounting flange is designed to DIN 28 138

Mixmaster V-II-BS™ Dimensional Information (mm)

d3	d7	d1	nx d2	d4	d8	Øk	L1	L2	d10	d20	A,B	C	L3	L4	a1
40	38	175	4x18	110	92	145	204	32	M12	M16	G3/8	G1/8	19	149	132
50	48	240	8x18	176	136	210	213	32	M12	M16	G3/8	G1/8	17	152	155
60	58	240	8x18	176	140	210	217	32	M12	M16	G3/8	G1/8	17	155	164
80	78	275	8x22	204	155	240	253	45	M16	M20	G1/2	G1/8	20	179	204
100	98	305	8x22	234	187	270	256	45	M16	M20	G1/2	G1/8	20	179	215
125	120	330	8x22	260	213	295	293	46	M20	M20	G1/2	G1/8	20	200	275
140	135	395	12x22	313	251	350	306	46	M20	M20	G1/2	G1/8	20	208	285

Dimensional information on larger sizes is available on request.

The seal range is also available without the bearing assembly, as shown on the right hand side of the above diagram. A single seal option which includes the bearing is available on request.

Mixmaster VI™

The Mixmaster VI™ uses the modular components of the Mixmaster V™ and incorporates double balanced seal faces.

The seal is designed in accordance with DIN 28 138. The Mixmaster VI™ is a standard design which can only be customized in 3 ways: 1 - thick sleeve, 2 - flange modification, 3 – exotic alloy wetted components. For any other modifications refer to the Mixmaster IV™ design.



The seal is offered with the following features:

- Top entry seal design
- Designed for mixers, agitators and reactors
- Double balanced inboard seal faces (Mixmaster VI™)
- Cartridge seal with integral load carrying bearing to DIN 28 138 parts 1 & 2
- No shaft fretting
- Modular design

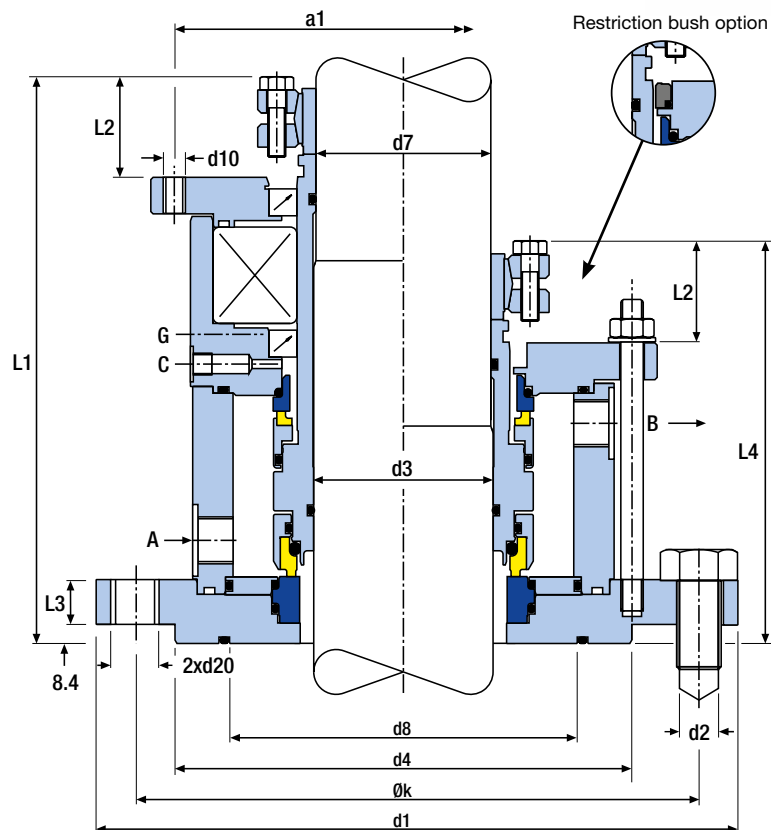

NOTE: The mounting flange can be supplied to suit customer equipment

Mixmaster VI-II-BS™ Dimensional Information (mm)

d3	d7	d1	nx2	d4	d8	Øk	L1	L2	d10	d20	A,B	C	L3	L4	a1
40	38	175	4x18	110	92	145	204	32	M12	M16	G3/8	G1/8	19	149	132
50	48	240	8x18	176	136	210	213	32	M12	M16	G3/8	G1/8	17	152	155
60	58	240	8x18	176	140	210	217	32	M12	M16	G3/8	G1/8	17	155	164
80	78	275	8x22	204	155	240	253	45	M16	M20	G1/2	G1/8	20	179	204
100	98	305	8x22	234	187	270	256	45	M16	M20	G1/2	G1/8	20	179	215
125	120	330	8x22	260	213	295	293	46	M20	M20	G1/2	G1/8	20	200	275
140	135	395	12x22	313	251	350	306	46	M20	M20	G1/2	G1/8	20	208	285

Dimensional information on larger sizes is available on request.

The seal range is also available without the bearing assembly, as shown on the right hand side of the above diagram. A single seal option which includes the bearing is available on request.

Mixmaster VI™ Flange Options

Extensive design modularity has been incorporated into the standard Mixmaster VI™ range.

In addition to the standard stainless steel flange design, AESSEAL® offers four further alternates as shown below.

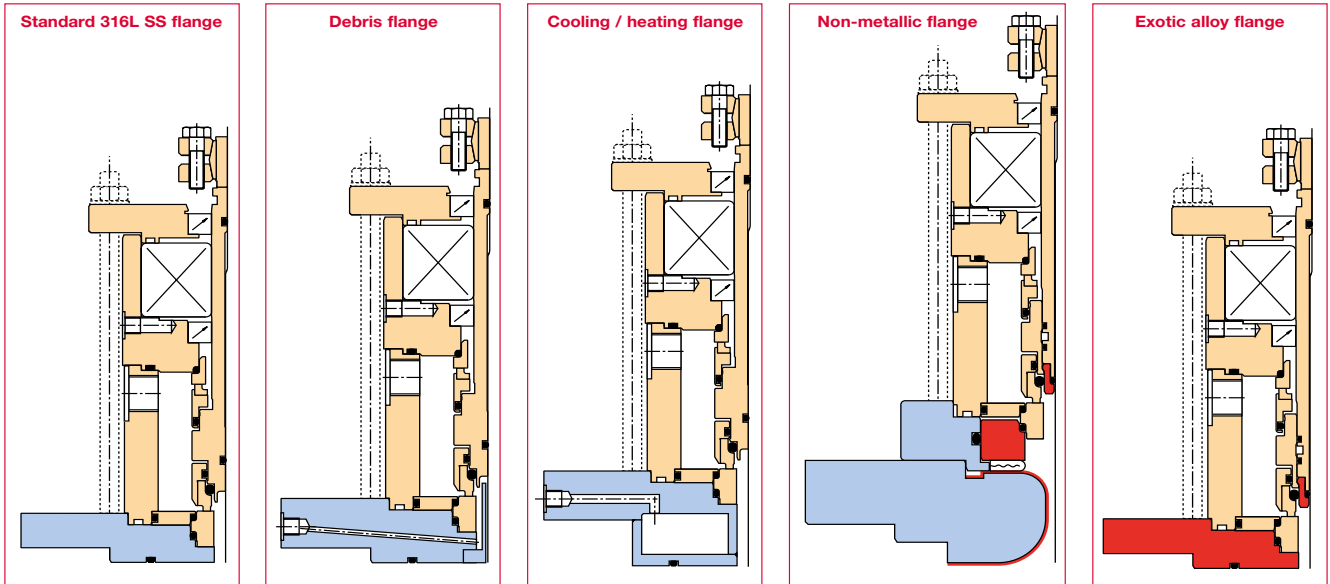

Debris Flange

In some applications, particularly in the food or pharmaceutical industries, an in-place cleaning operation such as CIP is required.

In addition to this, often on vertical applications, carbon seal face debris is not permitted to enter the process media.

The Debris Flange with optional deflector arrangement is offered to facilitate such process requirements.

Cooling / Heating Flange

Changing the seal environment is often key when sealing difficult applications.

The Cooling / Heating flange option allows the temperature at the seal faces to be controlled, thereby helping to extend seal life in some difficult thermal applications.

Non-Metallic Flange

To complement the non-metallic product offering, AESSEAL® offers inventoried enamel flanges conforming to DIN 28 137 part 2.

The Mixmaster VI™ non-metallic design also allows the cartridge seal to be removed and replaced without disturbing the enamelled flange. Cooling option available

Exotic Alloy Flange

The standard Mixmaster VI™ Exotic flange option is designed to DIN 28 141 and offered in any commercially available material including Alloy C276 and Titanium.

While some DIN style Stainless Steel, enamel and exotic flanges are inventoried, most flanges are made to suit customer requirements.



MIXMASTER VII™

Range of Mixer, Agitator, Reactor & Dryer
Seals for Dry Running Applications

The seal range is offered with the following design features:

- Designed for mixers, agitators, reactors and dryers
- Specifically for dry nitrogen applications to 10 barg (150 psig)
- Double hydraulically balanced seal faces
- Available with non-metallic wetted components
- Cartridge seal with integral load carrying bearing to DIN 28 138 parts 1 and 2
- No shaft fretting and available to suit any shaft (within the size range)

Specifications Mixmaster VII™

MIXMASTER VII™ Load Carrying Capabilities			
ØD3		DIN 28 159 Max Loads	
40mm	(1.500")	1,562 N	351 lbs
50mm	(2.000")	3,468 N	779 lbs
60mm	(2.375")	6,640 N	1,492 lbs
80mm	(3.125")	17,289 N	3,886 lbs
100mm	(4.000")	34,820 N	7,827 lbs
125mm	(5.000")	44,188 N	9,933 lbs
140mm	(5.500")	38,147 N	8,575 lbs
160mm	(6.250")	60,185 N	13,530 lbs

The Mixmaster VII™ range of mixer seals conform to the following relevant DIN Specifications:

- DIN 28 138 part 1** - Stainless Mixer Seal
- DIN 28 138 part 2** - Glass Lined
- DIN 28 138 part 3** - Screwed Connection Designation & Position
- DIN 28 137 part 2** - Glass Lined Mounting Flanges
- DIN 28 141** - Stainless Steel Mounting Flanges
- DIN 28 154 & 159** - Shaft Dimensions

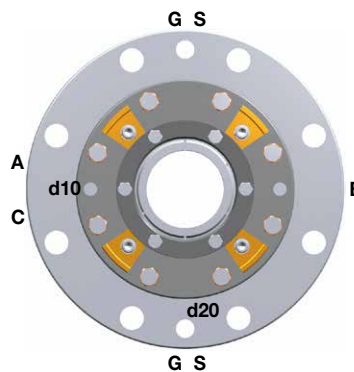

- A** = Barrier IN
- B** = Barrier OUT
- C** = Leakage to Atmosphere
- G** = Grease Port
- S** = Stationary Cooling Port
- d10** = Lifting Threads
- d20** = Jacking Threads

Mixmaster VII™ & Mixmaster VII-D™

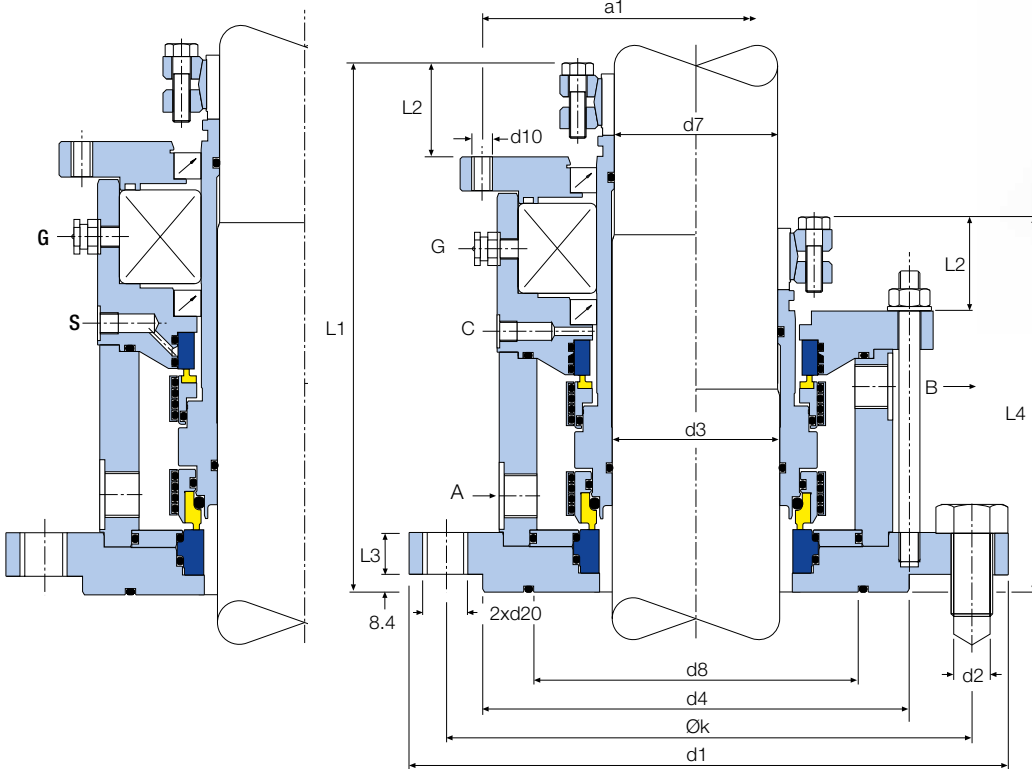

Mixmaster VII-D™
Double seal with bearing & outboard cooled stationary.

Mixmaster VII™
Double seal with bearing & outboard close-coupled stationary.

Mixmaster VII™
Double seal without bearing & with outboard close-coupled stationary.

Mixmaster VII™ Stainless Steel Dimensional Information (mm)

d3	d7	d1	nxd2	d4	d8	Øk	L1	L2	d10	d20	A,B	C	S	L3	L4	a1
40	38	175	4x18	110	92	145	208	32	M12	M16	G3/8	G1/8	G1/8	19	149	132
50	48	240	8x18	176	136	210	213	32	M12	M16	G3/8	G1/8	G1/8	17	152	155
60	58	240	8x18	176	140	210	217	32	M12	M16	G3/8	G1/8	G1/8	17	155	164
80	78	275	8x22	204	155	240	253	45	M16	M20	G1/2	G1/8	G1/4	20	179	204
100	98	305	8x22	234	187	270	256	45	M16	M20	G1/2	G1/8	G1/4	20	179	215
125	120	330	8x22	260	213	295	293	46	M20	M20	G1/2	G1/8	G1/4	20	200	275
140	135	395	12x22	313	251	350	306	46	M20	M20	G1/2	G1/8	G1/4	20	208	285
160	150	395	12x22	313	251	350	306	46	M20	M20	G1/2	G1/8	G1/4	25	208	292

Dimensional information on larger sizes is available on request.

Mixmaster VII™ Imperial Size Information

The modular design of the Mixmaster VII™ enables the product to be offered to suit ANY shaft size. The table below shows the inch size range. Larger sizes up to 300mm (12.000") are designed to order.

Mixmaster VII™ Stainless Steel Dimensional Information (inches)

d3	d7	d1	nxd2	d4	d8	Øk	L1	L2	d10	d20	A,B	C	S	L3	L4	a1
1.125" - 1.500"	-	6.890"	4 x 0.700"	4.33"	3.62"	5.71"	8.19"	1.26"	M12	M16	G3/8	G1/8	G1/8	0.59"	5.87"	5.20"
1.625" - 1.875"	-	9.450"	4 x 0.700"	6.93"	5.35"	8.26"	8.38"	1.26"	M12	M16	G3/8	G1/8	G1/8	0.67"	5.98"	6.10"
2.000" - 2.375"	-	9.450"	4 x 0.700"	6.93"	5.51"	8.26"	8.54"	1.26"	M12	M16	G3/8	G1/8	G1/8	0.67"	6.10"	6.46"
2.500" - 3.125"	-	10.830"	8 x 0.875"	8.03"	6.10"	9.45"	9.96"	1.77"	M16	M20	G1/2	G1/8	G1/4	0.79"	7.05"	8.03"
3.250" - 4.000"	-	12.000"	8 x 0.875"	9.21"	7.36"	10.63"	10.10"	1.77"	M16	M20	G1/2	G1/8	G1/4	0.79"	7.05"	8.46"
4.125" - 5.000"	-	13.000"	8 x 0.875"	10.24"	8.38"	11.61"	11.54"	1.81"	M20	M20	G1/2	G1/8	G1/4	0.79"	7.87"	10.83"
5.125" - 5.500"	-	15.550"	12 x 0.875"	12.32"	9.88"	13.78"	12.05"	1.81"	M20	M20	G1/2	G1/8	G1/4	0.79"	8.19"	11.22"
5.625" - 6.250"	-	15.550"	12 x 0.875"	12.32"	9.88"	13.78"	12.05"	1.81"	M20	M20	G1/2	G1/8	G1/4	0.98"	8.19"	11.50"

Dimensional information on larger sizes is available on request.

Mixmaster VII™ & VII-D™

Special metal (Exotic) & non-metallic designs

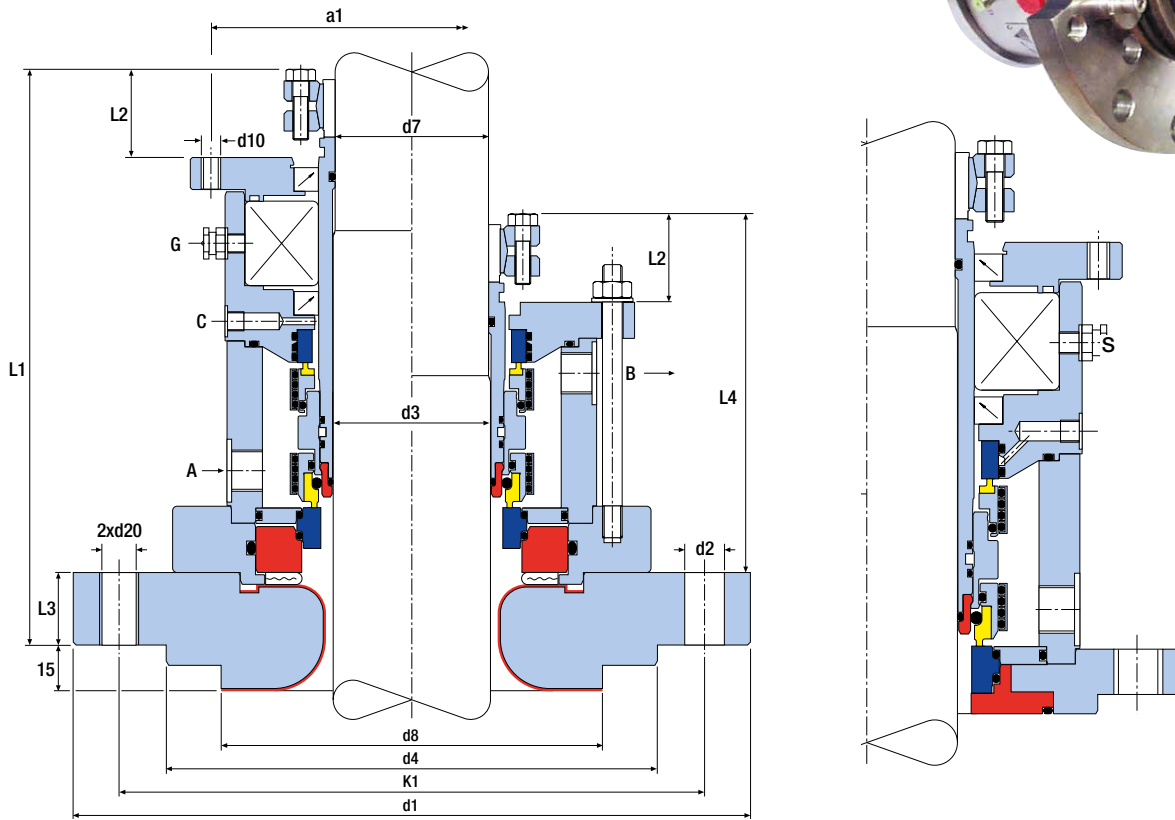

Non-metallic Mixmaster VII™
Double seal with Bearing & Outboard
Close-coupled Stationary.

Non-metallic Mixmaster VII™
Double seal without Bearing & with
Outboard Close-coupled Stationary.

Exotic Mixmaster VII-D™
Double seal with Bearing &
Outboard Cooled Stationary.

E700-E901 Flange Nominal Diameters

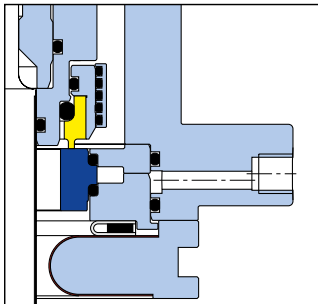

Exotic Mixmaster VII-DD™
Double seal with bearing & cooled
stationary seats.

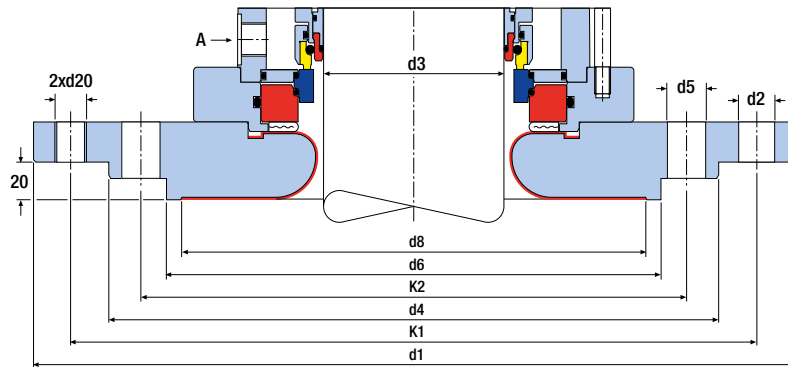

Mixmaster VII-BG™ Size Chart (mm)

d3	d7	d1	nx d2	d4	nx d5	d6	d8	d10	d20	a1	L1	K1	K2	L3	L2	L4	A,B	C	S	NFD
40	38	175	4x18	110	-	-	102	M12	M16	132.5	225	145	-	20	33	146	G3/8	G1/8	G1/8	E125
50	48	240	8x18	176	-	-	138	M12	M16	155	236	210	-	25	33	152	G3/8	G1/8	G1/8	E200
60	58	275	8x22	204	-	-	188	M12	M16	164	240	240	-	25	34	155	G3/8	G1/8	G1/8	E250
80	78	305	8x22	234	-	-	212	M16	M20	204	280	270	-	30	45	181	G1/2	G1/8	G1/4	E300
100	98	395	12x22	313	-	-	268	M16	M20	215	283	350	-	30	45	181	G1/2	G1/8	G1/4	E500
125	120	505	4x22	422	12x22	320	306	M20	M20	275	319	460	350	30	46	202	G1/2	G1/8	G1/4	E700
140	135	505	4x22	422	12x22	320	306	M20	M20	285	332	460	350	30	52	210	G1/2	G1/8	G1/4	E700
160	150	505	4x22	422	12x22	320	306	M20	M20	292	328	460	350	30	52	210	G1/2	G1/8	G1/4	E900
160*	150	565	4x26	474	12x22	370	356	M20	M20	292	328	515	400	30	52	210	G1/2	G1/8	G1/4	E901

Dimensional information on larger sizes is available on request.

* Nominal size 161

Mixmaster DGS

The Mixmaster DGS is a cartridge double back-to-back pusher seal with integral deep groove ball bearing. It is gas lubricated, non-contacting, inboard and outboard design, running on a supplied barrier gas at a pressure greater than the sealed process pressure.

The non-contacting nature of the design ensures long life, low power consumption and reduced capital cost for support systems. Also, a non-contacting inboard and outboard ensures 100% product purity with no process contamination, as well as eliminating contact and creating a wear free environment.

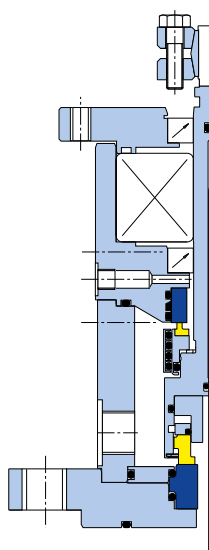

Stainless steel option

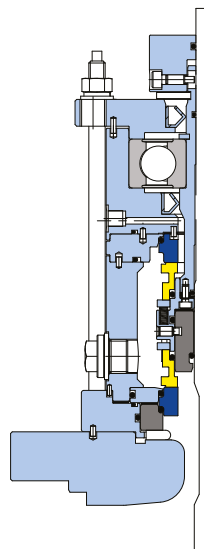

Glass lined option

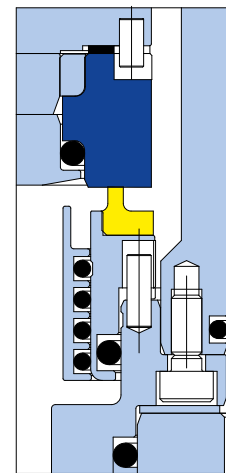

Dry-running contacting outboard face option

Conforms to:

- DIN 28 138 part 1** - Stainless Mixer Seal
- DIN 28 138 part 2** - Glass Lined
- DIN 28 138 part 3** - Screwed Connection Designation & Position
- DIN 28 137 part 2** - Glass Lined Mounting Flanges
- DIN 28 141** - Stainless Steel Mounting Flanges
- DIN 28 154 & 159** - Shaft Dimensions

Key Features

- Double mixer seal
- Inboard and outboard non-contacting gas lift faces
- Option with outboard contacting dry-running faces considered upon application
- Integral radial and axial load carrying deep groove ball bearing
- Face design optimized and calibrated for minimum barrier gas consumption
- Seal face materials conform to FDA and EU 1935/2004 legislation
- Uni-directional groove profile as standard and Bi-directional groove profile optional
- Available with metallic or non-metallic wetted components

Engineered Specials for Filter Dryer

Cartridge mounted dual rotary design seals with multi-spring pusher type sealing elements. The seal is of a non shaft-fretting design, fully hydraulically balanced, with the springs (constructed in Alloy 276) out of the product.

The seal comes complete with a unique fully machined gland and a sleeve end cap designed to accommodate the filter dryer shaft bellows and the axial movement of the filter dryer shaft.

The seal elements are designed to allow a CIP process and as part of the design an integral steady bearing is included to allow maximum seal face support. As standard, the seal is supplied with NPT barrier in and barrier out connections to allow the use of the gas barrier system.

Features and Advantages

- Elastomer groove design enables effective CIP cleaning with minimal / no debris entrapment
- Springs are removed from the process fluid ensuring that the process cannot clog or cause hang up of the dynamic O'rings
- Face design is optimized using FEA techniques. Faces are designed to run in compression under normal operating conditions and remain parallel at all times
- The design is repair friendly as all seal faces are monolithic and can be removed with simple hand tools, a full spares kit can be fitted in a short space of time unlike, shrink fit designs
- Designed specifically for pharmaceutical duties with CIP requirements
- Optional bi-metal wetted parts construction. The internal stationary face holder incorporated large anti rotation mechanism for robust face drive integrity
- Seal drive is provided by a key drive mechanism to provide positive radial drive whilst still allowing the axial movement of the shaft during the drying cycle
- Fully integrated bearing arrangement to provide support to the sleeve mechanism, thereby improving face integrity

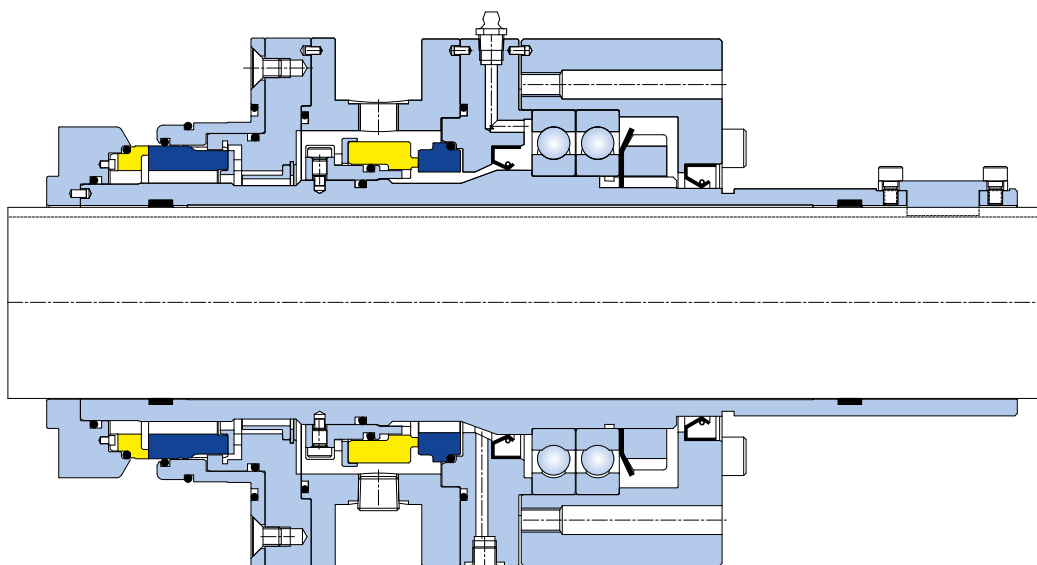

Glass lined Mixmaster with CLIP™

Mixmaster seals using CLIP™ inboard and out board sealing technology for the food and pharmaceutical industrial sectors.

For use on stainless steel and glass lined equipment, Mixmaster with CLIP™ seal on the outboard, optional inboard CLIP™ when running conditions allow. All Mixmaster VII's have the modular option of an outboard cartridge Lip seal design using AESSEAL® CLIP™ seal technology. A popular choice in the Mixmaster configuration, due to the integral bearing support, the CLIP™ seal runs on an extended and hardened inner barrel and may be offered in a FDA compliant material.

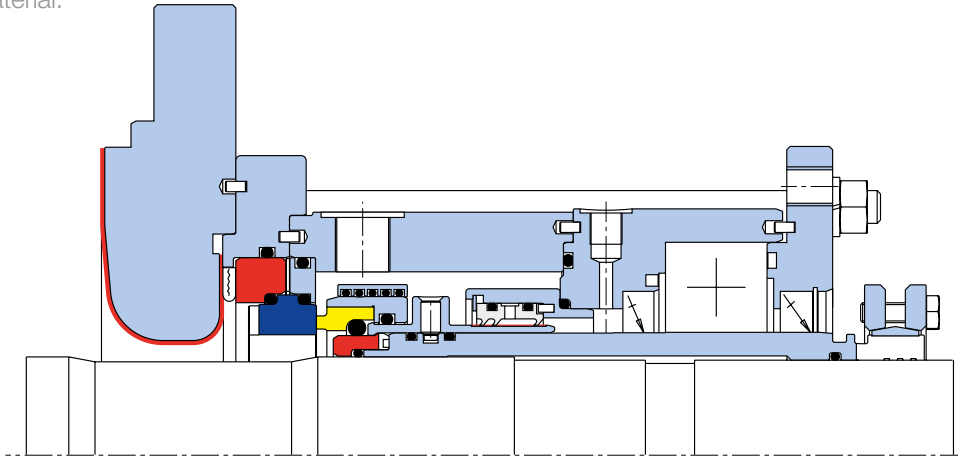

Environmental Control Systems For Mixer Seals

In addition to a vast range of mechanical seals, AESSEAL® also has a comprehensive range of seal support systems and bearing protection devices for all your sealing needs.

The systems below are compatible with a wide selection of barrier and buffer fluid media. They are supplied pre-assembled with all necessary components and fittings. On site inventory costs are reduced by modular system construction. For more information go to www.aesseal.com/systems



Standard Gas Panel



SP System



Stainless Steel Gas Panel



EasyClean™



AES-15™



EXPERIENCE THE EXCEPTIONAL

To experience the exceptional, please contact your local representative. Discover full details on our website:

www.aesseal.com

This brochure is fully recyclable. When laminated, a sustainable, biodegradable and recyclable lamination is used.

For further information and safe operating limits contact our technical specialists at the locations below.



Use double mechanical seals with hazardous products.

Always take safety precautions:

- Guard your equipment
- Wear protective clothing

WARNING

UK Sales & Technical advice:

AESSEAL plc
Mill Close
Bradmarsh Business Park
Rotherham, S60 1BZ, UK

Tel: +44 (0) 1709 369966

Fax: +44 (0) 1709 720788

E-mail: seals@aesseeal.com

www.aesseal.com



THE QUEEN'S AWARDS
FOR ENTERPRISE:
INNOVATION
2016

AESSEAL plc is certified to ISO 9001, ISO 14001, ISO 27001, ISO 29001, ISO 37001, ISO 50001 and OHSAS 18001.

'Our purpose is to give our customers such exceptional service that they need never consider alternative sources of supply.'



INVESTOR
IN PEOPLE

USA Sales & Technical advice:

AESSEAL Inc.
355 Dunavant Drive
Rockford,
TN. 37853, USA

Tel: +1 865 531 0192

Fax: +1 865 531 0571

E-mail: usa@aesseeal.com

www.aesseal.com

Important: Since the conditions and methods of use of this product are beyond our control, AESSEAL plc expressly disclaims any and all liability resulting or arising from any use of this product or reliance on any information contained in this document - AESSEAL plc standard conditions of sale apply. All sizes are subject to manufacturing tolerances. We reserve the right to modify specifications at any time. AESSEAL® is a Registered Trademark of AES Engineering Ltd, AESSEAL plc recognizes all trademarks and trademark names as the property of their owners.