

Proportional Relief Valves

RV, RL and RM Series



Check Valves
Relief Valves

Proportional Relief Valves

RV, RL and RM Series

Introduction

FITOK relief valves OPEN when system pressure reaches the set pressure and CLOSE when system pressure falls below the set pressure.



Features

- ⦿ Set pressure:
 - RV series: 7 color-coded springs available for a wide range of set pressures, 50 to 6000 psig @ 70°F (3.4 to 414 bar @ 20°C)
 - RL series: 10 to 225 psig @ 70°F (0.68 to 15.5 bar @ 20°C)
 - RM series: 3 color-coded springs available for a wide range of set pressures, 50 to 1500 psig @ 70°F (3.4 to 103 bar @ 20°C)
- ⦿ Maximum outlet pressure:
 - RV series: 1500 psig (103 bar)
 - RL series: 225 psig (15.5 bar)
 - RM series: 1500 psig (103 bar)
- ⦿ Orifice size:
 - RV series: 0.14" (3.6 mm)
 - RL series: 0.19" (4.8 mm) and 0.25" (6.4 mm)
 - RM series: 0.25" (6.4 mm)
- ⦿ Back pressure
 - Back pressure is the pressure of the outlet of valves. It increases the set pressure of proportional relief valves.
 - RV and RM series: Balanced stem design to eliminate the effect of system back pressure
 - RL series: Pre-set pressure = Desired pressure - 0.8 × Back pressure
- ⦿ Working temperature: -40°F to 300°F (-40°C to 148°C)
- ⦿ Variety of end connections
- ⦿ Liquid or gas service
- ⦿ Adjustable bonnet cap and adjustable set pressure
- ⦿ Lead seal lock wire through lock wire holes to lock proportional relief valve so as to secure a set pressure effectively
- ⦿ Variety of seal materials
- ⦿ Label identifies the set pressure range

Applications

Relief valves are proportional relief valves that open gradually as the pressure increases. Consequently, they do not have a capacity rating at a given pressure rise (accumulation), and they are not certified to ASME or any other codes.

- ⚠ **Some system applications require relief valves to meet specific safety codes. The system designer and user must determine when such codes apply and whether these relief valves conform to them.**
- ⚠ **FITOK proportional relief valves should never be used as ASME Boiler and Pressure Vessel Code safety relief devices.**
- ⚠ **FITOK proportional relief valves are not "Safety Accessories" as defined in the Pressure Equipment Directive 2014/68/EU.**

Pressure-Temperature Rated Value

Series	RV					RM				RL				
Max. Inlet Pressure ^①	6000 psig (413 bar), up to 8000 psig (551 bar) during relief process					6000 psig (413 bar)				300 psig (20.6 bar)				
Max. Allowable ^① Outlet Pressure	1500 psig (103 bar)					1500 psig (103 bar)				225 psig (15.5 bar)				
Set Pressure	50 to 6000 psig (3.4 to 413 bar)					50 to 1500 psig (3.4 to 105 bar)				10 to 225 psig (0.7 to 15.5 bar)				
Sealing Material	FKM	Buna-N	Neoprene	EPDM	FFKM	FKM	Buna-N	Neoprene	EPDM	FKM	Buna-N	Neoprene	EPDM	FFKM
Temperature, °C (°F)	Max. Set Pressure, psig (bar)													
-40 (-40)			-									-	-	
-34 (-30)														
-23 (-10)	-				-	-				-				-
-17 (0)														
-12 (10)														
-4 (25)		6000 (413)		6000 (413)				1500 (103)						
-1 (30)			6000 (413)				1500 (103)		1500 (103)					
4 (40)	6000 (413)				6000 (413)	1500 (103)								
10 (50)										225 (15.5)		225 (15.5)		
20 (70)														
65 (150)	5580 (384)	5580 (384)	3000 (207)	5580 (384)	5580 (384)									225 (15.5)
93 (200)	5160 (355)	5160 (355)	1500 (103)	5160 (355)	5160 (355)			700 (48)						
121 (250)	4910 (338)	4910 (338)		4910 (338)	4910 (338)	700 (48)								
135 (275)			-		2500 (172)									
148 (300)	-	-												

① Outlet pressure shall not exceed inlet pressure.

Set Pressure and Resealing Pressure

Set pressure: The set pressure is the upstream pressure at which the first indication of flow occurs.

The repeatability of set pressure of each valve after initial relief is ±5% at room temperature.

From 60 to 80°F (15 to 26°C), ±3.0 psig (0.20 bar) or ±5% of the initial set pressure (whichever is higher).

Below 60°F (15°C) and above 80°F (26°C), ±6.0 psig (0.40 bar) or ±20% of the initial set pressure (whichever is higher).

Resealing pressure: The resealing pressure is the upstream pressure at which there is no indication of flow.

Resealing pressure is always lower than set pressure.

Note: For valves not acutated for a period of time, the initial relief pressure may be higher than the set pressure.

Series	Test Set Pressure psig (bar)	Percentage of the Set Pressure as the Minimum Resealing Pressure, %
RL	10 to 20 (0.7 to 1.3)	50
	175 to 225 (12.0 to 15.5)	91
RV/RM	100 to 200 (6.8 to 13.7)	50
	850 to 1000 (58.5 to 68.9)	85

Flow Data at 70°F (20°C)

Air

RV and RM Series

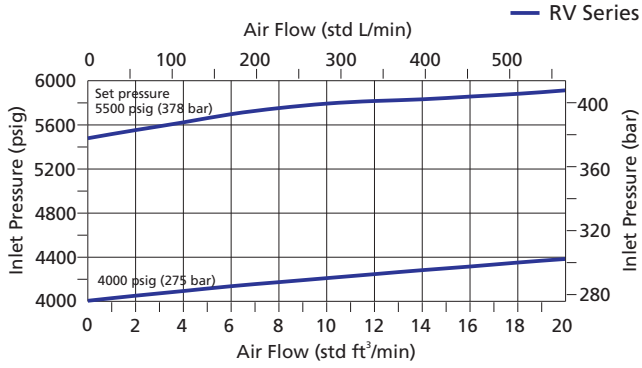

Water

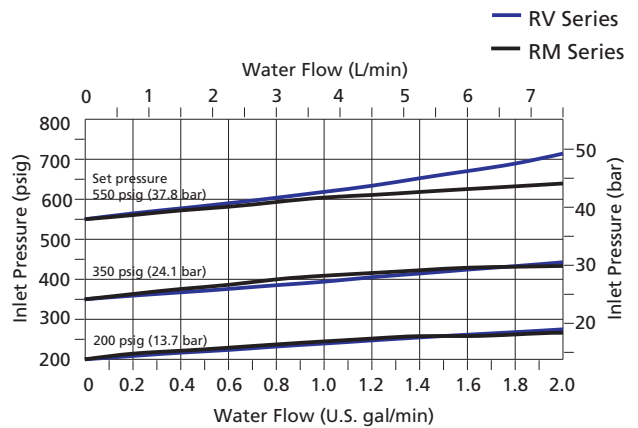
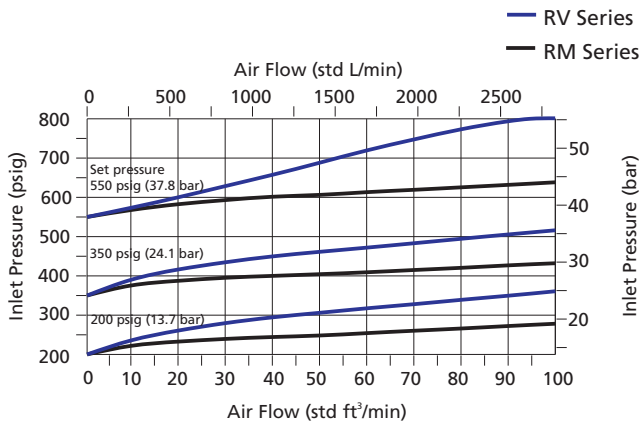
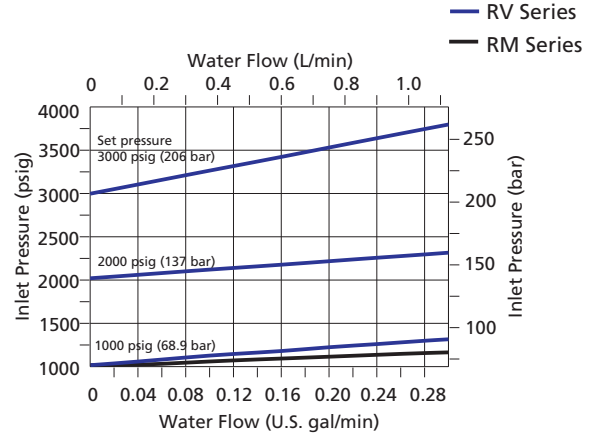
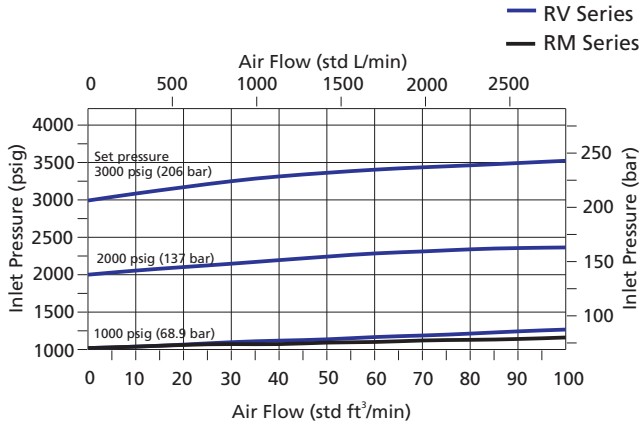
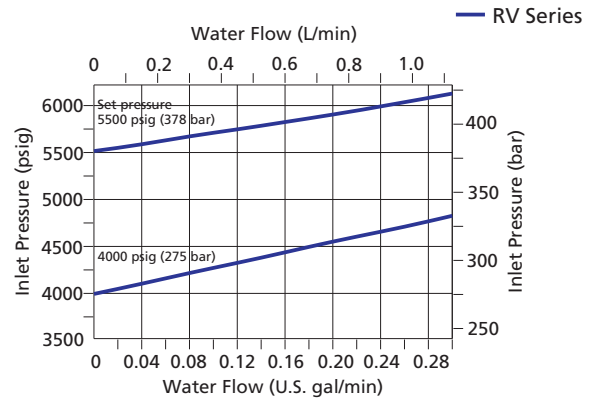

RL Series

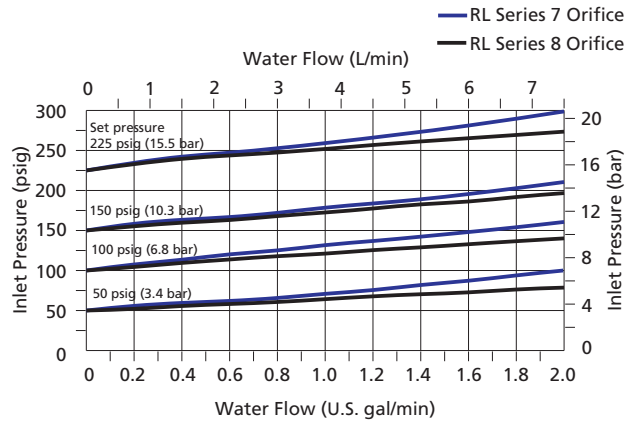
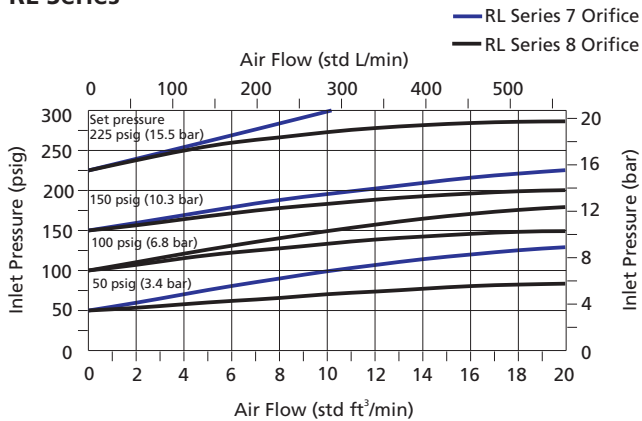

Check Valves
Relief Valves

Standard Materials of Construction

RV Series

Component		Material Grade/ASTM Specification
1	<i>Body</i>	316 SS/A182
2	<i>Seat</i>	316 SS/A479
3	<i>O-ring</i>	Fluorocarbon FKM
4	<i>Gasket</i>	PEEK
5	<i>Seat Retainer</i>	316 SS/A479
6	<i>O-ring</i>	Fluorocarbon FKM
7	<i>Stem</i>	316 SS/A479
8	<i>O-ring</i>	Fluorocarbon FKM
9	<i>Bonnet</i>	316 SS/A479
10	<i>Spring Support</i>	316 SS/A479
11	<i>Spring</i>	S17700 SS/AMS 5678
12	<i>Lock Nut</i>	17-4PH powdered metal
13	<i>Label</i>	Polyester
14	<i>Bonnet Cap</i>	316 SS/A479

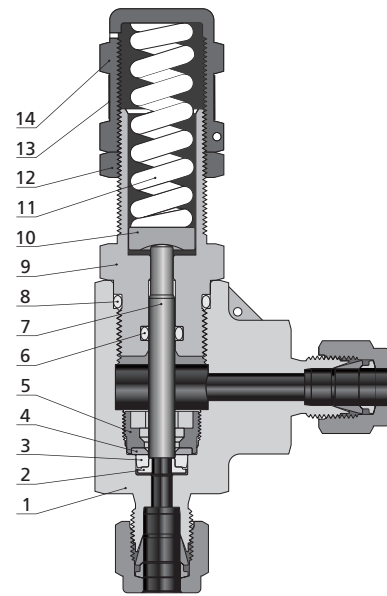

Note: Wetted components are listed in italics.

1. Lubricant: Silicone-based
2. Contact FITOK Group or our authorized distributors for other materials

RL Series

Component		Material Grade/ASTM Specification
1	<i>Body</i>	316 SS/A182
2	<i>Gasket</i>	316 SS/A479
3	<i>Seat</i>	316 SS/A479
4	<i>Bonded disc</i>	316 SS/A479+Fluorocarbon FKM
5	<i>Stem</i>	316 SS/A479
6	<i>Retainer</i>	316 SS/A479
6a	<i>Ring</i>	316 SS/A479
7	<i>Quad Seal</i>	Fluorocarbon FKM
8	<i>O-ring</i>	Fluorocarbon FKM
9	<i>Bonnet</i>	316 SS/A479
10	<i>Spring Support</i>	316 SS/A479
11	<i>Spring</i>	S17700 SS/AMS 5678
12	<i>Lock Nut</i>	17-4PH powdered metal
13	<i>Sleeve</i>	304SS/A240
14	<i>Label</i>	Polyester
15	<i>Bonnet Cap</i>	316 SS/A479

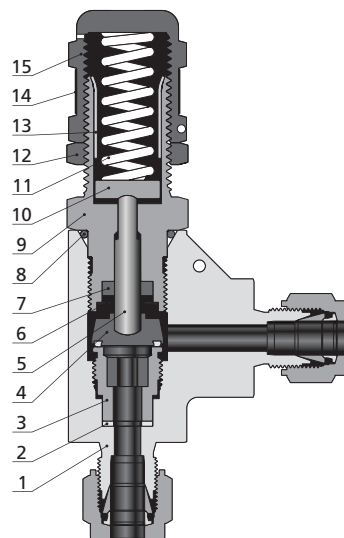

Orifice 7
0.19 in. (4.8 mm)

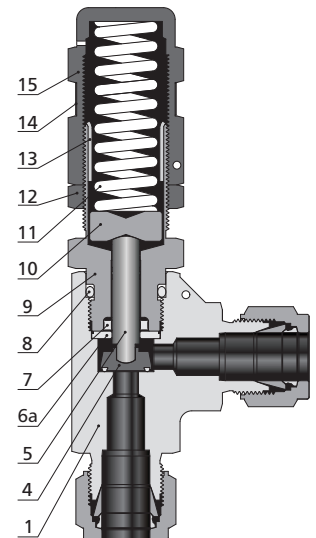

Orifice 8
0.25 in. (6.4 mm)

Note: Wetted components are listed in italics.

1. Lubricant: Silicone-based
2. Contact FITOK Group or our authorized distributors for other materials

RM Series

Component		Material Grade/ASTM Specification
1	Body	316 SS/A182
2	Stem	316 SS/A479+Fluorocarbon FKM
3	Retainer	316 SS/A479
4	Square sealing piece	Fluorocarbon FKM
5	Bonnet	316 SS/A479
6	O-ring	Fluorocarbon FKM
7	Spring Support	316 SS/A479
8	Spring	S17700 SS/AMS 5678
9	Lock Nut	17-4PH powdered metal
10	Label	Polyester
11	Bonnet Cap	316 SS/A479

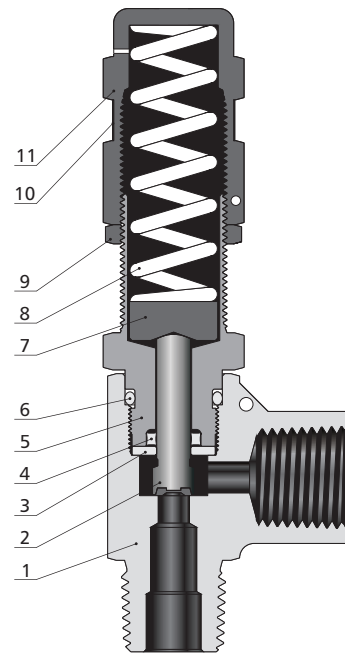

Note: Wetted components are listed in italics.

1. Lubricant: Silicone-based

2. Contact FITOK Group or our authorized distributors for other materials

Manual Override Handles

Lift the aluminum handle with hand to open the proportional relief valve without changing the set pressure.
For use on the following valves :

RV Series — set pressure range 50~1500 psig

RL Series — set pressure range 10~225 psig

RM Series— set pressure range 50~300 psig

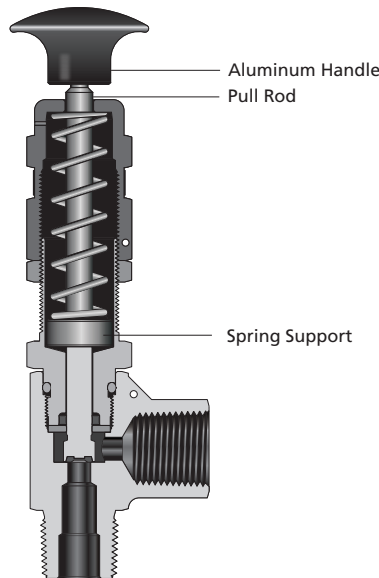

Dimensions

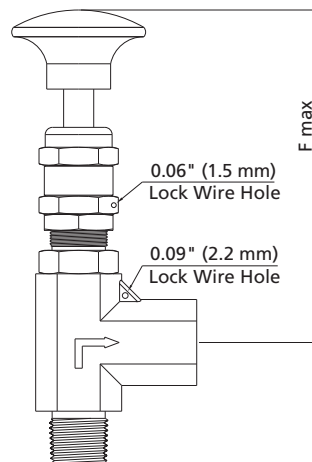
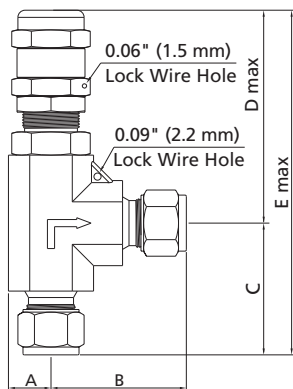

Check Valves
Relief Valves

RV Series

Basic Ordering Number	Connection Type and Size		Orifice in. (mm)	Dimensions, in. (mm)					
	Inlet	Outlet		A	B	C	D	E	F
RV□□-FL4-6-□	1/4" FITOK	1/4" FITOK	0.14 (3.6)	0.46 (11.9)	1.60 (40.6)	1.44 (36.6)	2.70 (68.6)	4.14 (105.2)	3.68 (98.0)
RV□□-FL6-6-□	3/8" FITOK	3/8" FITOK							
RV□□-FL8-6-□	1/2" FITOK	1/2" FITOK							
RV□□-ML6-6-□	6 mm FITOK	6 mm FITOK		0.46 (11.9)	1.60 (40.6)	1.44 (36.6)	2.70 (68.6)	4.14 (105.2)	
RV□□-ML8-6-□	8 mm FITOK	8 mm FITOK							
RV□□-ML12-6-□	12 mm FITOK	12 mm FITOK							
RV□□-FNS4-6-□	1/4 Female NPT	1/4 Female NPT		0.46 (11.9)	1.17 (29.7)	1.38 (34.9)	2.70 (68.6)	4.08 (103.5)	
RV□□-NS4-6-□	1/4 Male NPT	1/4 Male NPT							
RV□□-FRT4-6-□	1/4 Female BSPT	1/4 Female BSPT							

RL Series

Basic Ordering Number	Connection Type and Size		Orifice in. (mm)	Dimensions, in. (mm)					
	Inlet Size	Outlet Size		A	B	C	D	E	F
RL□□-FL4-7	1/4" FITOK	1/4" FITOK	0.19 (4.8)	0.46 (11.9)	1.60 (40.6)	1.44 (36.6)	4.14 (105.0)	3.74 (95.0)	
RL□□-ML6-7	6 mm FITOK	6 mm FITOK							
RL□□-NS4-7	1/4 Male NPT	1/4 Male NPT							
RL□□-RT4-7	1/4 Male BSPT	1/4 Male BSPT			1.17 (29.7)	1.38 (34.9)	4.08 (103.5)		
RL□□-FNS4-7	1/4 Female NPT	1/4 Female NPT							
RL□□-FRT4-7	1/4 Female BSPT	1/4 Female BSPT							
RL□□-FL8-8	1/2" FITOK	1/2" FITOK	0.25 (6.4)	0.54 (13.7)	1.83 (46.5)	1.83 (46.5)	5.92 (150.0)	4.89 (124.3)	
RL□□-ML12-8	12 mm FITOK	12 mm FITOK							
RL□□-NS8-8	1/2 Male NPT	1/2 Male NPT							1.44 (36.6)
RL□□-RT8-8	1/2 Male BSPT	1/2 Male BSPT							
RL□□-FNS8-8	1/2 Female NPT	1/2 Female NPT							
RL□□-FRT8-8	1/2 Female BSPT	1/2 Female BSPT			0.58 (14.7)				

RM Series

Basic Ordering Number	Connection Type and Size		Orifice in. (mm)	Dimensions, in. (mm)					
	Inlet Size	Outlet Size		A	B	C	D	E	F
RM□□-FL8-8-□	1/2" FITOK	1/2" FITOK	0.25 (6.4)	0.54 (13.7)	1.83 (46.5)	1.83 (46.5)	3.87 (98.4)	5.73 (145.0)	4.89 (124.3)
RM□□-ML12-8-□	12 mm FITOK	12 mm FITOK							
RM□□-NS8-8-□	1/2 Male NPT	1/2 Male NPT							
RM□□-RT8-8-□	1/2 Male BSPT	1/2 Male BSPT		0.58 (14.7)	1.44 (36.6)	1.44 (36.6)	5.31 (135.0)		
RM□□-FNS8-8-□	1/2 Female NPT	1/2 Female NPT							
RM□□-FRT8-8-□	1/2 Female BSPT	1/2 Female BSPT							

1. FITOK means FITOK double ferrule tube fittings.
2. Dimensions are shown with FITOK nuts finger-tightened. All dimensions are for reference only and are subject to change.
3. Sizes and types listed are standard. For other connection types and sizes, please contact FITOK Group or our authorized distributors.

Sealing Kit

Series	Orifice Designator	Sealing Kit Basic Ordering Number					Sealing Kit Content
		FKM	Buna-N	Neoprene	EPDM	FFKM	
RV	6	VI-RV-6	BN-RV-6	N-RV-6	E-RV-6	Z-RV-6	O-ring (3)
RL	7	RLSS-7-VI	RLSS-7-B	RLSS-7-N	RLSS-7-E	RLSS-7-Z	O-ring, square sealing piece, adhesive disc, retainer
	8	RLSS-8-VI	RLSS-8-B	RLSS-8-N	RLSS-8-E	RLSS-8-Z	O-ring, square sealing piece, adhesive disc
RM	8	RMSS-8-VI	RMSS-8-B	RMSS-8-N	RMSS-8-E	-	O-ring, square sealing piece, stem

The basic ordering number of the listed RL and RM series sealing kits specifies 316 stainless steel.
For other materials, such as alloy 400, replace SS with M in the basic ordering number, for example: RLM-7-VI

Spring Kit

Series	Orifice Designator	Spring Kit Basic Ordering Number	Set Pressure Range psig (bar)	Spring Color
RV	6	7PRV-SP6-F-B	50 to 300 (3.4 to 20.7)	Green
		7PRV-SP6-O-B	300 to 700 (20.7 to 48.3)	Orange
		7PRV-SP6-Y-B	700 to 1500 (48.3 to 103)	Yellow
		7PRV-SP6-P-B	1500 to 2500 (103 to 172)	Purple
		7PRV-SP6-W-B	2500 to 3500 (172 to 241)	White
		7PRV-SP6-J-B	3500 to 4500 (241 to 310)	Blue
		7PRV-SP6-C-B	4500 to 6000 (310 to 414)	Red
RL	7	7PRL-SP7-Y-B	10 to 255 (0.7 to 15)	Yellow
	8	7PRL-SP8-Y-B		
RM	8	7PRM-SP8-F-B	50 to 300 (3.4 to 20.7)	Green
		7PRM-SP8-O-B	300 to 700 (20.7 to 48.3)	Orange
		7PRM-SP8-Y-B	700 to 1500 (48.3 to 103)	Yellow

The content of the spring kit includes: spring and label.
To order spring kit with springs, labels, and lead seal lock wire, add "-L" to the spring kit basic ordering number.
For example: 7PRV-SP6-F-B-L.

Ordering Number Description

Valves

RVSS – FL6 – ML8 – 6Z – WM – TSF2

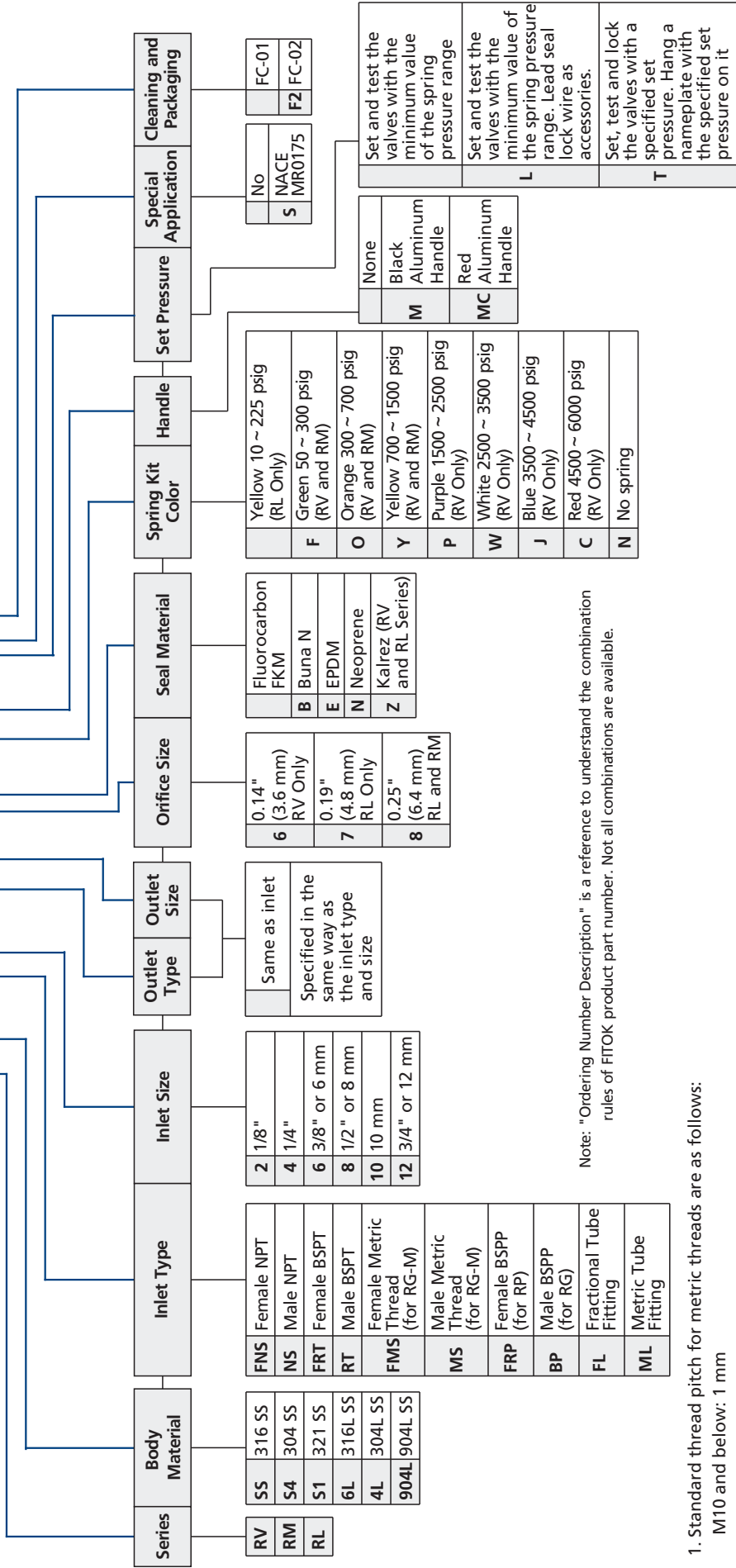

Check Valves
Relief Valves

Series	Body Material	Inlet Type	Inlet Size	Outlet Type	Outlet Size	Seal Material	Spring Kit Color	Handle	Set Pressure	Special Application	Cleaning and Packaging				
RV	SS 316 SS	FNS Female NPT	2 1/8"	Same as inlet	0.14" (3.6 mm) RV Only	Fluorocarbon FKM	Yellow 10 ~ 225 psig (RL Only)	None	None	No	FC-01				
RM	S4 304 SS	NS Male NPT	4 1/4"									Specified in the same way as the inlet type and size	B Buna N	F Green 50 ~ 300 psig (RV and RM)	Black Aluminum Handle
RL	S1 321 SS	FRT Female BSPT	6 3/8" or 6 mm	E EPDM	O Orange 300 ~ 700 psig (RV and RM)	MC Aluminum Handle	S MR0175	T							
	6L 316L SS	RT Male BSPT	8 1/2" or 8 mm						N Neoprene	Y Yellow 700 ~ 1500 psig (RV and RM)	Red Aluminum Handle				
	4L 304L SS	FMS Female Metric Thread (for RG-M)	10 10 mm	Z Kalrez (RV and RL Series)	P Purple 1500 ~ 2500 psig (RV Only)										
	904L 904L SS	MS Male Metric Thread (for RG-M)	12 3/4" or 12 mm							W White 2500 ~ 3500 psig (RV Only)					
		FRP Female BSPP (for RP)			J Blue 3500 ~ 4500 psig (RV Only)										
		BP Male BSPP (for RG)								C Red 4500 ~ 6000 psig (RV Only)					
		FL Fractional Tube Fitting			N No spring										
		ML Metric Tube Fitting													

Note: "Ordering Number Description" is a reference to understand the combination rules of FITOK product part number. Not all combinations are available.

- Standard thread pitch for metric threads are as follows:
M10 and below: 1 mm
M12 to M24: 1.5 mm
M27 and above: 2 mm
Standard thread pitch should be ignored in the ordering number, others should be specified.

- Cleaning and Packaging:
FC-01: Standard cleaning and packaging for general industrial procedures.
FC-02: Special cleaning and packaging for wetted system components to ensure compliance with product cleaning requirement of ASTM G93 Level C.
3. For proportional relief valve with a specified set pressure and a nameplate, set pressure value can be added as suffix to the part number.
The set pressure value should be within the set pressure range of the selected spring, and the following requirements should be followed:
10 psig ≤ set pressure value ≤ 500 psig, take the minimum interval of 1 psig, for example: RVSS-FL4-6-F-T-101PSIG;
500 psig ≤ set pressure value ≤ 1000 psig, take the minimum interval of 5 psig, for example: RVSS-FL4-6-O-T-505PSIG;
1000 psig ≤ set pressure value ≤ 6000 psig, take the minimum interval of 10 psig, for example: RVSS-FL4-6-Y-T-1010PSIG.