

ABEL CM

From the reciprocating positive displacement pump specialist

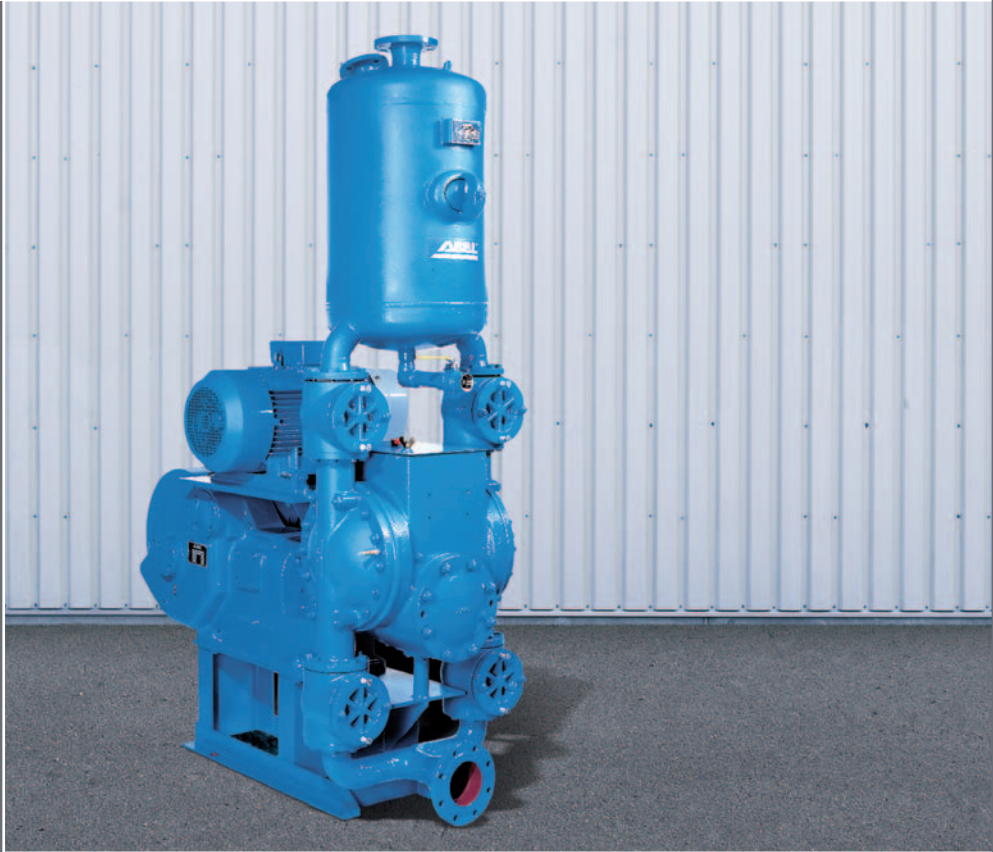

Compact Membrane (Diaphragm) Pumps

Piston Diaphragm pumps
for difficult media

ABEL CM - Performance range: up to 30 m³/h (130 GPM); up to 2.5 MPa (362 psi)

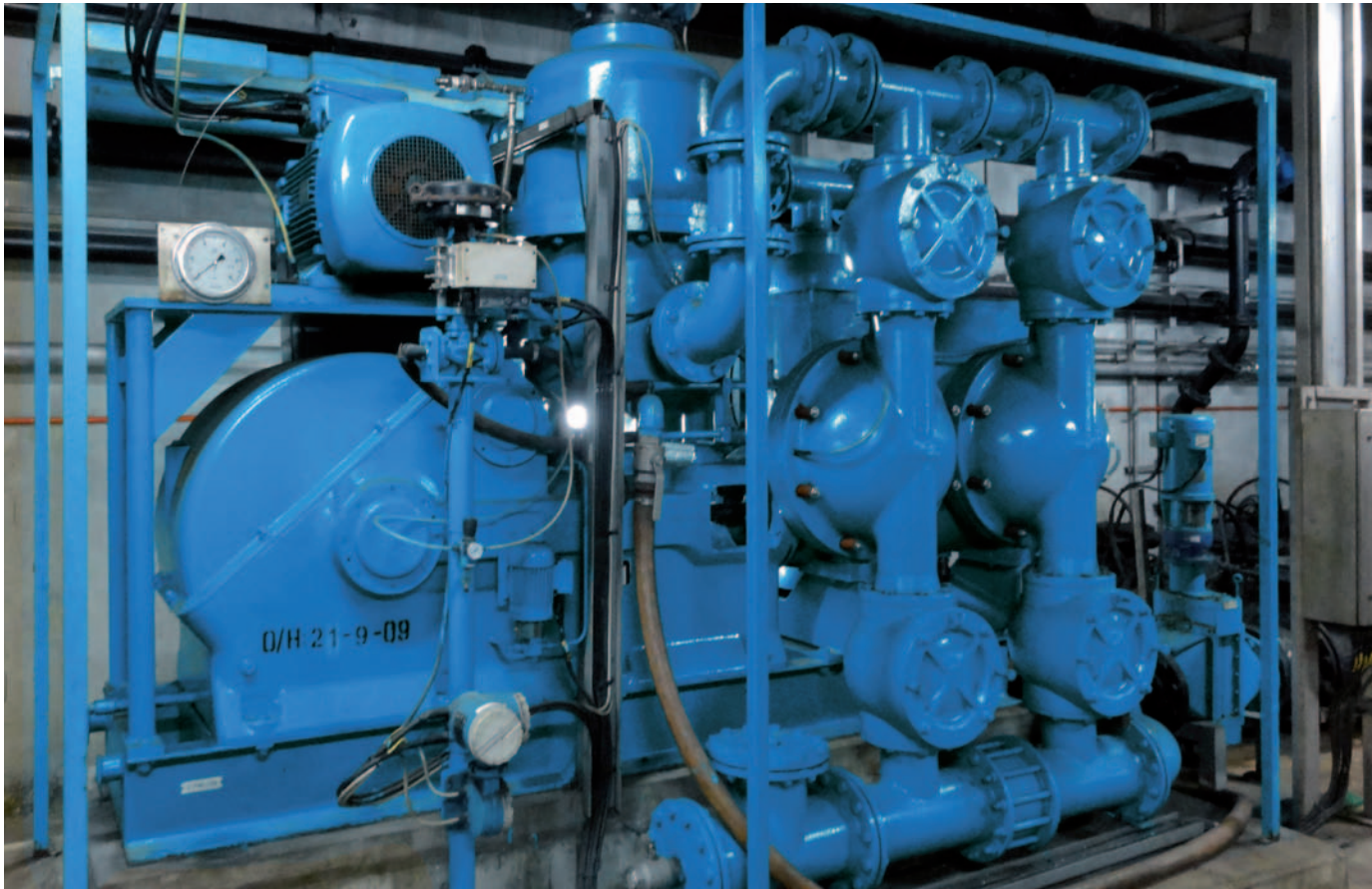

ABEL CM piston membrane pumps for raw sewage transfer in a large WWTP in Asia

ABEL CM piston membrane pumps are single or double-action specialized pumps that are used for difficult media. They are highly resistant to wear, even when used at high pressures over an extended period of time. Their true double-membrane technology offers a high degree of safety.

When used as a pump for feeding filter presses, the rugged, automatic flow rate control (which does not use complex electronics) is another impressive feature that makes it even more reliable.

ABEL CM pumps – specialists for difficult media

- for sludge transfer
- feeding filter presses, rotary kilns, or spray driers (spray dryer feed pump)
- raw sewage transfer
- transfer of abrasive, corrosive, acidic, alkaline, pigmented, viscous, and grainy media

 Available with ATEX certification.

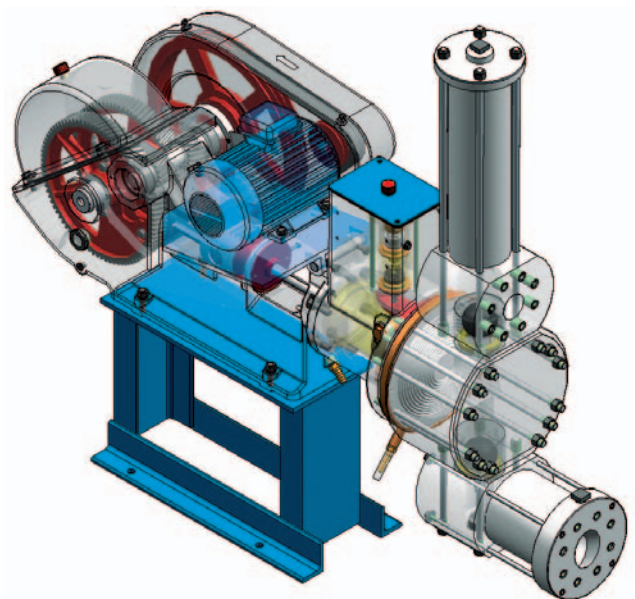

ABEL CM in plastic design for transfer of aggressive fluids

Operational reliability through double membrane technology

In the event the product or hydraulic medium penetrates into the intermediate space of the double membrane, it is immediately detected by the integrated control function before the product gets into the hydraulic media or vice versa. Alternatively, an automatic alarm is activated by an electrical control.

The advantages of ABEL CM

- operational reliability through double membrane technology
- up to 30 m³/h (130 GPM)
- up to 2.5 MPa (362 psi)
- tested design
- optimal controllability
- long life
- serviceability
- plastic design (Polypropylene wet end) available

ABEL piston membrane pumps have created the reputation of the firm ABEL as a leading manufacturer of reciprocating positive displacement pumps, making them world market leader in filter press feeding (Hydraulic Institute, 1999).

The CM technology

- optimal design to withstand high pressures
- maximum filling efficiency
- hermetically sealed
- product side without gland packings
- ball or conical valves
- valve housing with inspection openings
- visual or electrical membrane control indicator
- safety valve and automatic liquid supplement in the primary circulation
- central pressure control during filter press operation
- automatic membrane position control

Optimum design

The technical details described below that make the ABEL Compact Membrane Pumps so unparalleled in function and quality.



Ball valves with inspection opening and membrane leakage detection device



Tested, stable design. ABEL CM piston membrane pump for filter press feed



CM piston membrane pumps in a water treatment works in Northern Ireland

Valve balls for precision and durability

Through the combination of two soft materials ABEL Compact Membrane Pumps run smoothly.

In the standard version the pumps are fitted with machine-ground polyurethane valve balls of highest precision and seats made of polyethylene or polyurethane. Of course, many other combinations are available.

Controlled flow characteristics for feeding filter presses

The membrane stroke control by means of the control valve automatically adapts the flow rate to the throughput characteristics of the filter presses.

The control valve is calibrated for each application on the ABEL test stand so as to limit the final operating pressure.

Another plus for operational reliability

In many situations where the environment is not conducive to using electronic speed controls, especially in the surface refinement sector and the disposal industry, customers avoid using frequency converters for the control of filter press feed pumps. In these situations, the ABEL CM piston membrane pump proves its strength.

By utilizing a pressure dependent membrane stroke control system, the capacity of the pump is automatically reduced as the system pressure increases without the use of a frequency converter.

Valve for membrane stroke control

Double membrane

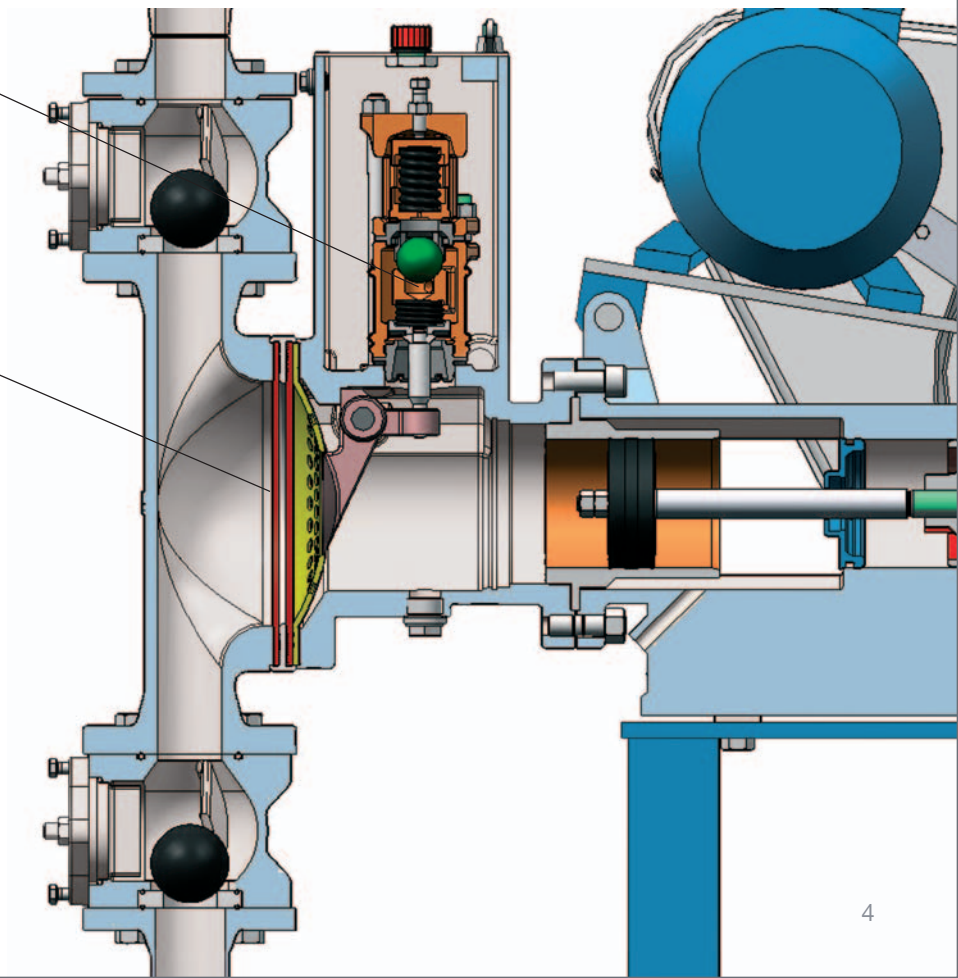

Industries and applications



ABEL CM-pump for spray dryer feed

Use of compact membrane pumps as feed pumps for spray dryers

ABEL CM piston membrane pumps feed ceramic slip with defined pressure through the spray nozzles into the drying chamber of the spray dryer.

The use of existing vertical plunger pumps caused the following problems:

- leakage in the cylinder due to highly erosive slurry
- damage of the piston caused by grain content in the slip
- high water consumption due to packing gland flushing
- difficult replacement of spare parts due to complicated design of the pumps
- difficult and messy maintenance due to the use of oil as hydraulic medium
- pulsation in the discharge pipe

ABEL CM piston membrane pumps enable the transfer of highly abrasive, even grainy suspensions by using high-strength special membranes and ball valves, which prevent the medium being pumped from coming into contact with the piston and other mechanical control elements of the pump.

The use of big-volume pulsation dampeners dependably avoids high pulsation and therefore the discontinuous discharge of the slurry over the entire pressure range.

A frequency controlled drive allows exact flow adjustment in dependence upon the nozzle wear rate and thus a pressure control and an adaption to the handling of various slip qualities to different granulates.



Waste water – sewage treatment works and pumping stations



Energy/power plants – flue gas desulphurization



Cement industry – rotary kiln feed



Steel works – transfer of pickle and scaling slurries



Diaphragm Pumps
Solids Handling Pumps
High Pressure Pumps
Marine Pumps

For North America
ABEL Pumps, L.P.
+1 (412) 741 3222
abelpumpsus@idexcorp.com

For Spain, Portugal, Central and South America
ABEL Equipos S.A.
+34 (91) 715 4848
aeq-mail@idexcorp.com