

BT Series Drum Pumps



FINISH THOMPSON INC.

BTS



Tube Length
40" (102cm)

Sealed, High Viscosity

High viscosity sealed design with PTFE screw-type lifting compressors for liquids up to 15,000 cP.

- Features:** Stainless steel tube construction
 Tube interchangeable with motors
 Up to 15,000 cP with 3 hp motor

Applications: Oils, resins, solvents*, adhesives, polymers, gear lube, glycerin

Construction Specifications

Pump Model	Construction Materials		Tube Diameter in (cm)	Discharge Size & Type	Hose Size in (cm)	Max. Temp.		Min. Temp.	
	Outer Tube	Internals				°F	°C	°F	°C
BTS	316 Stainless Steel	316 Stainless Steel, PTFE	2 (5.1)	1-1/2" Hose Barb	1-1/2 (3.8)	200	93	-20	-29

Performance Data

Maximum Flow**		Maximum Head**		Maximum Specific Gravity	Maximum Viscosity	
Electric gpm (lpm)	Air gpm (lpm)	Electric ft (m)	Air ft (m)		Electric	Air
10 (38)	10 (38)	200 (61)	200 (61)	1.8	15000 cP	15000 cP

Viscosity Data

Viscosity (cP)	800	3,000	5,000	7,000	15,000
Max Flow gpm (lpm)	10 (38)	6 (23)	6 (23)	6 (23)	6 (23)
Max Head feet (meter)	80 (24)	80 (24)	125 (38)	175 (53)	200 (61)

Note: Maximum viscosity based on 60 Hz operation.

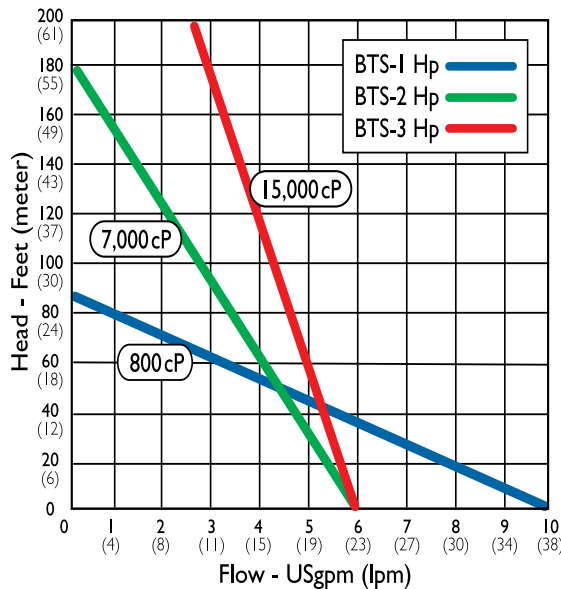

*When pumping flammables or combustibles, use explosion proof electric or air drive motors on stainless steel tubes with static protection kit.

Performance will vary with changes in fluid viscosity and specific gravity. All testing done at 60 Hz. **Performance reduced at 50 Hz. BT Series is not recommended for pumping thin water-like fluids.

Need help choosing a pump?
 Use the handy online Pump Selector at:
www.finishthompson.com.





TEFC
(M15, M16, M17, M27, M28, M29, M39, M40)
Ex-Proof TEFC
(M24X, M25X, M26X, M33X, M34X)

Air
(M18, M19, M20)

Model	Description	Certification	Electrical Requirements	Output	RPM	Maximum Viscosity cP
				kW		

TEFC (Totally Enclosed Fan Cooled), IP54 Motors

M15	Continuous duty, 12 ft. (3.5 m) cord.	*	230-460VAC/60 Hz	0.75	3,450	800
M16				1.5	1,725	7,000
M17				2.2	1,725	15,000
M27			115-230VAC/60 Hz	0.75	3,450	800
M28				1.5	1,725	7,000
M29				2.2	1,725	15,000
M39			220-380-440VAC/50-60 Hz	0.75	2,850	1,000
M40				1.5	1,425	8,500

Explosion Proof Motors

M33X	Suitable for use in hazardous areas, ideal for flammable liquids. Continuous duty rated.	*	115-230VAC/60 Hz	0.75	3,450	800
M34X				1.5	1,725	7,000
M24X			230-460VAC/60 Hz	0.75	3,450	800
M25X			230-460VAC/50-60 Hz	1.5	1,450/1,725	7,000
M26X				2.2	1,450/1,725	15,000

Air Motors^{†‡}

M18	Lightweight. Operates from customer-supplied compressed air source. Variable speed. Muffler and control valve supplied.	CE	100 psi @ 40-70 cfm	0.75	300-3,000	800
M19			100 psi @ 80-120 cfm	1.5	300-3,000	7,000
M20			100 psi @ 120-170 cfm	2.2	300-2,500	15,000

[†]An air motor is a non-electrical device meaning possibility of explosion from igniting flammables/combustibles is reduced. Air motor performance will depend upon user's system setup.

[‡]Motor suitable for hazardous areas that do not require independent certification.

*Carries independent testing laboratory approval.

Motor adapters are also available to permit installation of customer supplied NEMA or IEC motors.

Dimensions

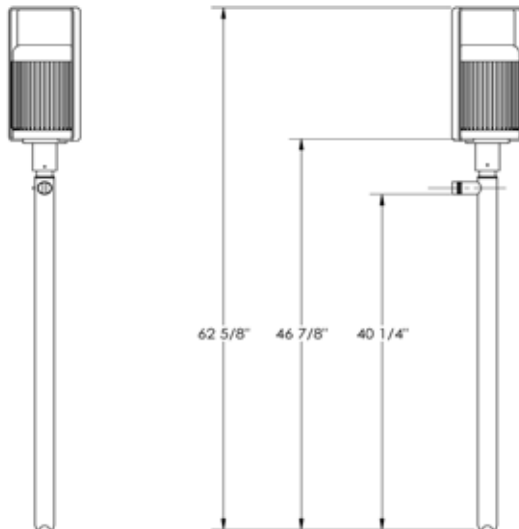

NOTE: DIMENSIONS ARE FOR REFERENCE ONLY

Accessories

Drum Adapters



Static Protection Kit



Discharge Hoses

