

MAGSON MA - size 7

Magnetically coupled centrifugal pumps
made of plastics PP



More than just pumps



MA type 7



- without shaft seal
- streamlined spiral housing made of PP
- volume flow of up to 950 l/min
- delivery head of up to 42 m.WC
- back pull-out



For all advantages of MAGSON pumps see page 9.

Characteristic curves

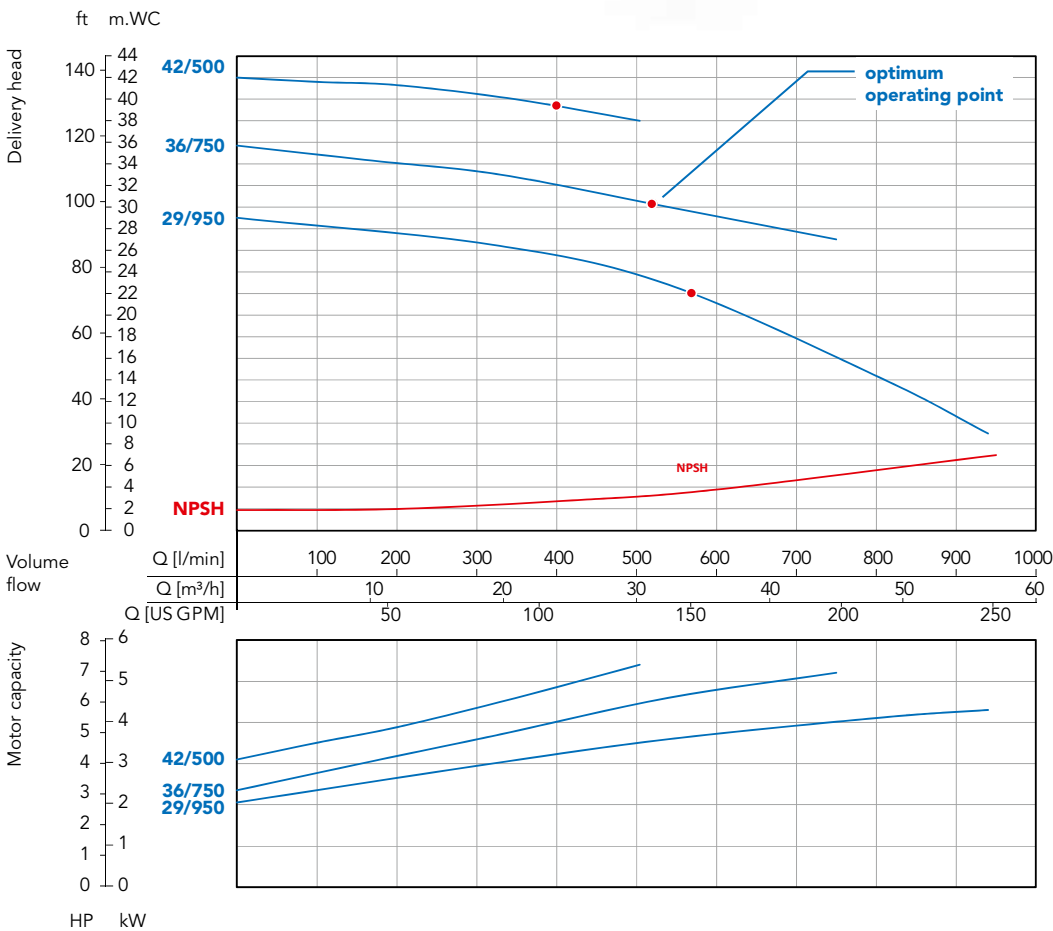

Determined with water of 20 °C;
measured values ± 10%

Technical data MA

Size	type 7		
	29/950	36/750	42/500
Material *	PP (glass-fibre reinforced)		
Max. delivery head in [m.WC] at 50 Hz	29		42
Max. volume flow in [l/min] at 50 Hz	950		500
Max. density in [g/cm ³] at 50 Hz**	1.0	1.2	1
Motor capacity in [kW]	4	5.5	5.5
Current rating (400 V, 50 Hz) in [A]	7.3	9.9	9.9
Rated speed in [rpm] at 50 Hz / 60 Hz	3000		
Suction port	DN 65		
Discharge port	DN 50		
Voltage in [V]	400 / 690		
Protection class	IP 55		
Max. flow velocity in [m/s]	suction side = 1 / discharge side = 3		
Max. temperature in [°C]	70		
Max. system pressure for PP / ETFE at 20 °C in [bar]	5		

* Material used for housing, impeller unit and rear casing: (sheath of inner magnet made of PP without fibre reinforcement)

** approx. value at max. volume flow (higher density possible when flow rate is reduced)

Dimensions in [mm]

Size	type7		
	29/950	36/750	42/500
Motor capacity in [kW]	4	5.5	5.5
Dimension L in [mm]	608	612	

Motor dimensions may differ according to manufacture.

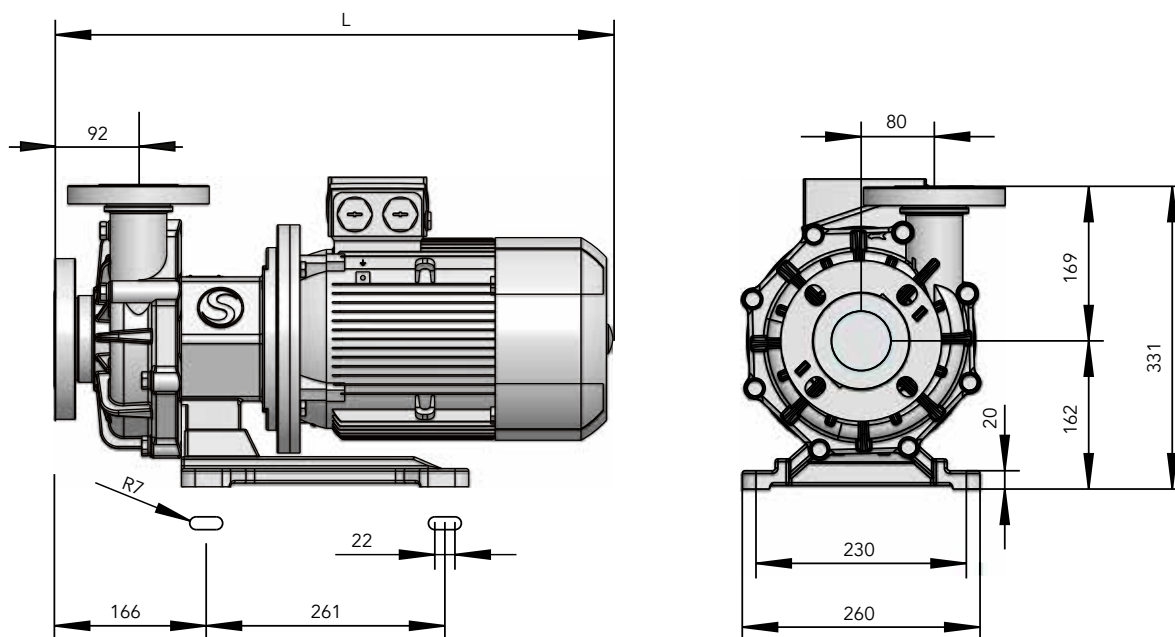



More than just pumps

Today the FLUX name is recognised around the globe as the trademark for top standards in pump technology. Everything started with the invention of the electric drum pump in 1950. Nowadays FLUX has an extensive range of products each of which can be customized. FLUX pumps are used for example in the chemical and pharmaceutical industries; in machinery and plant engineering as well as companies in electroplating, effluent treatment and the foodstuffs sector.

Whether single-product or system solution – FLUX quality is synonymous with a long service life, excellent economy and maximum safety.

In addition to the excellent product quality FLUX customers appreciate the superb level of expertise our staff has to offer as well as their genuine customer focus.

These days FLUX-GERÄTE GMBH supplies pumps to almost 100 countries around the globe.

FLUX-GERÄTE GMBH

Process Pumps & Systems

August-Horch-Strasse 2 · D-51149 Cologne
P. O. Box 920101 · D-51151 Cologne

Phone +49 2203 9394-0

Fax +49 2203 9394-48

info-process@flux-pumpen.de

www.flux-pumps.com