

Q155 Series Medium Pressure

API 674

Maximum Flow Rate: 295 l/min (78 gpm) 2674 BPD
Maximum Pressure: 241 bar (3500 psi)



WANNER
Hydra-Cell[®]
Seal-less Pump Technology



Available
to Meet
API 674

- Seal-less design eliminates leaks, hazards and the expense associated with seals and packing
- Low NPSH requirements allow for operation with a vacuum condition on the suction - positive suction pressure is not necessary
- Can operate with a closed or blocked suction line and run dry indefinitely without damage, eliminating downtime and repair costs
- Unique diaphragm design handles more abrasives with less wear than gear, screw or plunger pumps
- Hydraulically balanced diaphragms to handle high pressures with low stress
- Lower energy costs than centrifugal pumps
- Rugged construction for long life with minimal maintenance
- Compact design and double-ended shaft provide a variety of installation options

Q155 Medium Pressure Performance

Capacities

Flow					@ Pressure Rating		Pressure	
Model	Max. Input rpm	Max. Flow			psi	bar	Maximum Inlet Pressure	
		gpm	l/min	BPD			500 psi (34 bar)	
Q155K	450	78	295	2674	3000	207	Maximum Discharge Pressure	
Q155M	450	65	246	2228	3500	241	Q155K	3000 psi (207 bar)
Consult factory when operating below 200 rpm.							Q155M	3500 psi (241 bar)

Maximum Flow at Designated Pressure

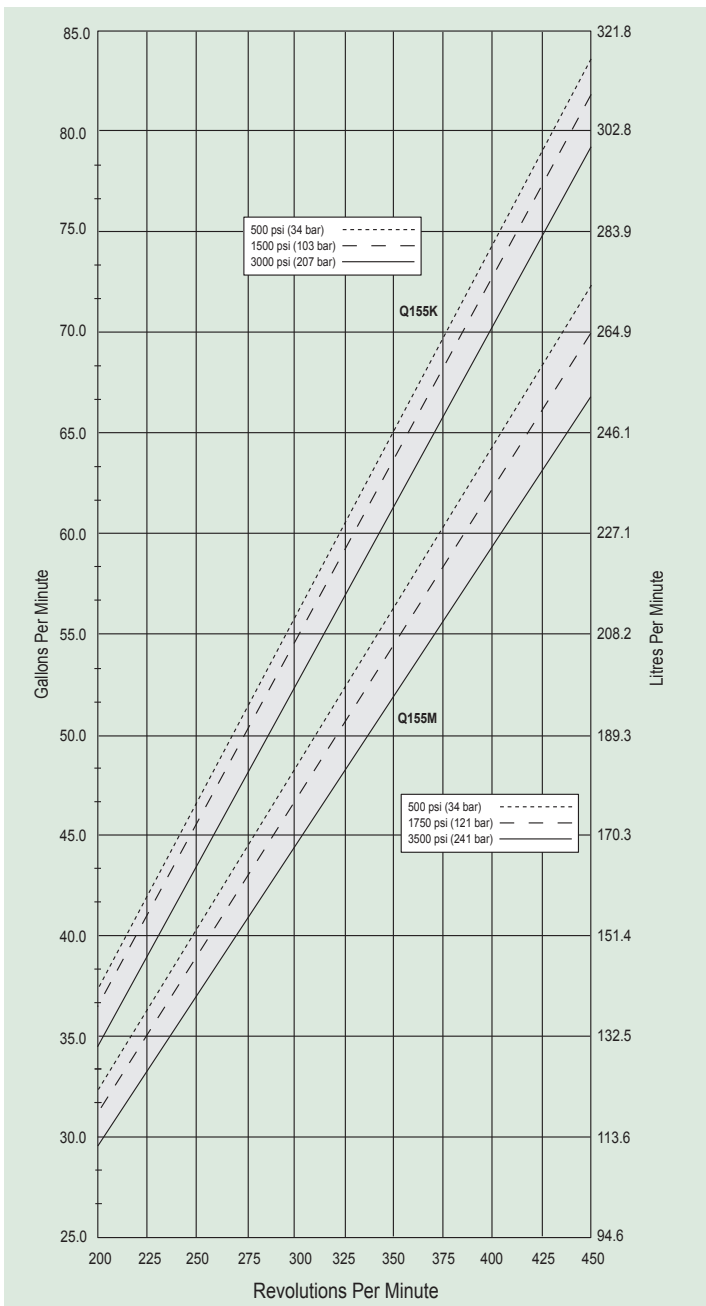

Note: Each pump complies with item 6.8.2 of API 674 across the full performance range.

Q155 Medium Pressure Specifications

Flow Capacities

Model	Pressure psi (bar)	rpm	gpm	l/min	BPD
Q155K	3000 (207)	450	78	295	2674
Q155M	3500 (241)	450	65	246	2228

Delivery

	Pressure psi (bar)	gal/rev	liters/rev
Q155K	500 (34)	0.185	0.700
	1500 (103)	0.181	0.685
	3000 (207)	0.173	0.654
Q155M	500 (34)	0.157	0.592
	1750 (121)	0.151	0.573
	3500 (241)	0.145	0.547

rpm

Maximum:	450
Minimum:	200 (Consult factory for speeds less than 200 rpm)

Maximum Discharge Pressure

Metallic Heads:	Q155K	3000 psi (207 bar)
	Q155M	3500 psi (241 bar)

Maximum Inlet Pressure 500 psi (34 bar)

Operating Temperature

Maximum:	180° F (82.2° C)
Minimum:	40° F (4.4° C)

Consult factory for temperatures outside this range

Maximum Solids Size	800 microns
Input Shaft	Left or Right Side
Inlet Ports	Weld Neck: 4" / SCH. 40 4" NPT, 4" Class 300 RF ANSI
Discharge Ports	Weld Neck: 2" / SCH. 160 2" NPT, 2" Class 2500 RTJ ANSI
Shaft Diameter	3 inch (76.2 mm)
Shaft Rotation	Uni-directional (see rotation arrows)
Oil Capacity	33.1 litres (35 US quarts) See page 5 for oil selection and specification.

Weight

Metallic Heads:	1700 lbs. (771 kg)
-----------------	--------------------

Fluid End Materials

Diaphragm Follower Screw:	316 Stainless Steel
Outlet Valve Retainer:	316 Stainless Steel
Plug-Outlet Valve Port:	316 Stainless Steel
Inlet Valve Retainer:	316 Stainless Steel

See page 5 for customer-specified fluid end materials choices.

Power End Materials

Crankshaft:	Forged Q&T Alloy Steel
Connecting Rods:	Ductile Iron
Crossheads:	12L14 Steel
Crankcase:	Ductile Iron
Bearings:	Spherical Roller/Journal (outer mains)
	Steel Backed Babbitt (crankpin)
	Bronze (wrist pin, center mains)

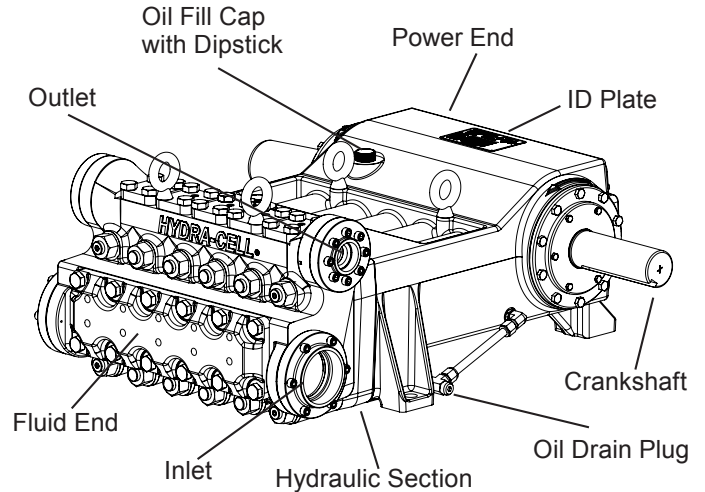

Calculating Required Horsepower (kW)*

$$\frac{\text{gpm} \times \text{psi}}{1,460} = \text{electric motor hp}^*$$

$$\frac{\text{lpm} \times \text{bar}}{511} = \text{electric motor kW}^*$$

* hp (kW) is required application power.

Attention!

When sizing motors with variable speed drives (VFD): It is very important to select a motor and a VFD rated for constant torque inverter duty service and that the motor is rated to meet the torque requirements of the pump throughout desired speed range.

Q155 Medium Pressure Dimensions

Threaded Version Inches (mm)

Front View

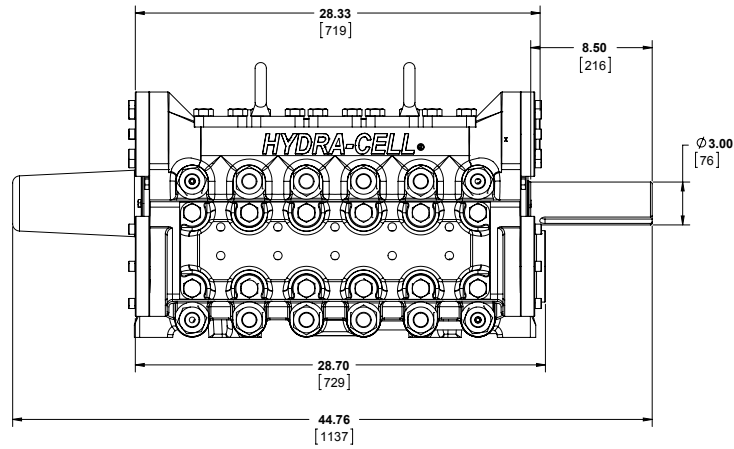

Side View

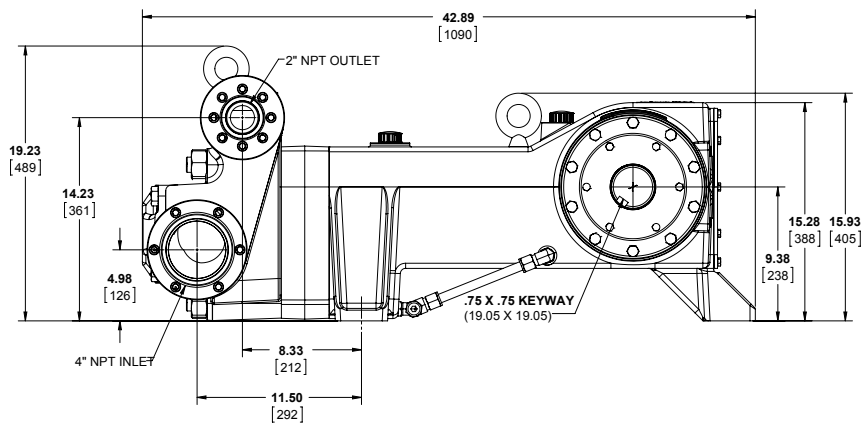

Bottom View

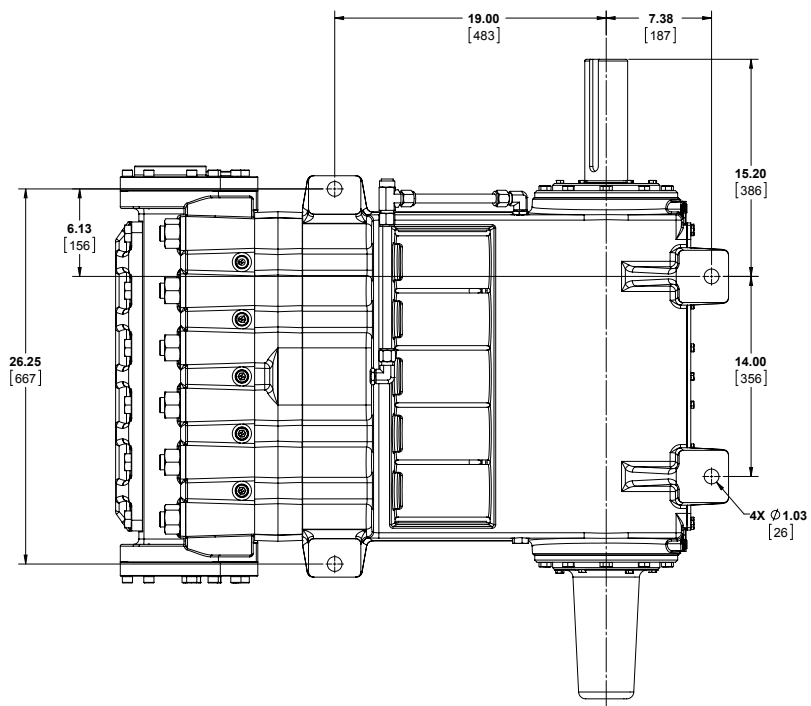

Q155 Series Medium Pressure **How to Order**

Ordering Information

1	2	3	4	5	6	7	8	9	10	11	12	13	14
Q	1	5	5										

A complete Q155 Series Medium Pressure Model contains 14 digits including 10 customer-specified design and materials options, for example: Q155MADTTTETAC.

Medium Pressure

Digit	Order Code	Description
1-4	Q155	Pump Configuration Shaft-driven API 674 - Contact Wanner International
5	K M -	Performance Max. 295 l/min (78 gpm) 2674 BPD @ 207 bar (3000 psi) Max. 246 l/min (65 gpm) 2228 BPD @ 241 bar (3500 psi) ATEX - Contact Wanner International <i>(Note: ATEX 2014/34/EU Certified, Category 2, Zone 1, Hazardous Liquids)</i>
6	A C D E F G R S T	Pump Head Version NPT Threaded Ports (Steel) Weld Neck (Steel) Weld Neck (316L Stainless Steel) Weld Neck (Hastelloy) Weld Neck (Duplex Alloy 2205) ANSI Flange Ports (Duplex Alloy 2205) ANSI Flange Ports (Steel) ANSI Flange Ports (316L Stainless Steel) ANSI Flange Ports (Hastelloy)
7	D G S T	Pump Head Material Nickel Aluminum Bronze (NAB) Duplex Alloy 2205 316 Stainless Steel Hastelloy CX2M
8	G T	Diaphragm & O-ring Material FKM Buna-N
9	D H N T	Valve Seat Material Tungsten Carbide* 17-4 Stainless Steel Nitronic 50 Hastelloy C
10	D F N T	Valve Material Tungsten Carbide* 17-4 Stainless Steel Nitronic 50 Hastelloy C

Digit	Order Code	Description
11	E T	Valve Springs Elgiloy Hastelloy C
12	H M P S T	Valve Spring Retainers 17-7 PH Stainless Steel PVDF Polypropylene 316 SST Hastelloy C
13	A B E H	Hydra-Oil 10W30 standard-duty oil 40-wt. Food-contact oil 15W50 high-temp severe-duty synthetic oil
14	C O X Y	Oil Level Monitor Cover Float switch, normally closed Float switch, normally open Float switch, explosion proof, normally closed No switch

Note: The Oil Level Monitor Cover is an assembly that replaces the previous back cover on Q155 Series pumps. It contains a float switch assembly that can trigger an alarm or shutdown when pre-defined levels of high or low oil are reached. It may also be ordered without a float switch cover.

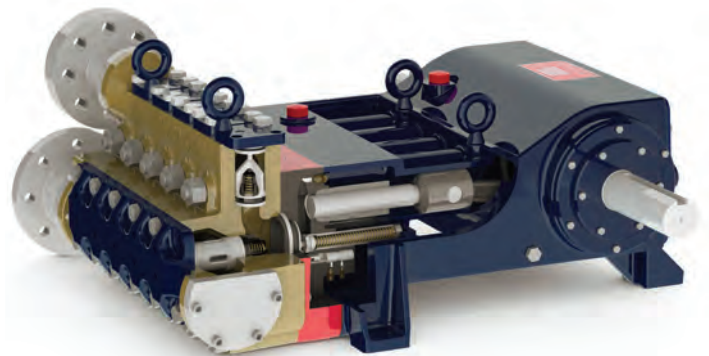

*Tungsten Carbide valve seat and disc are a matched set and must be purchased together.



WANNER ENGINEERING - WORLD HEADQUARTERS & MANUFACTURING
Minneapolis USA
t: (612) 332-5681
e: sales@wannereng.com

WANNER PUMPS
Kowloon HONG KONG
t: +852 3428 6534
e: sales@wannerpumps.com

WANNER INTERNATIONAL
Hampshire UK
t: +44 (0) 1252 816847
e: sales@wannerint.com

WANNER ENGINEERING
Latin American Office
t: +55 (11) 4081-7098
e: sales@wannereng.com

WANNER PUMPS
Shanghai CHINA
t: +86-21-6876 3700
e: sales@wannerpumps.com