

**Annex to the OPERATION AND  
INSTALLATION MANUAL  
of the ALMATEC pump series:  
E-Series, Chemicor und Biocor**

**Option Code BS  
Barrier Chamber System**

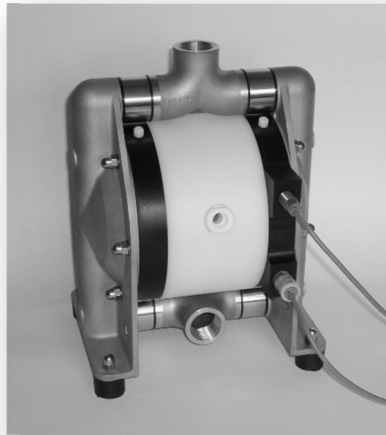

**Original Instruction**  
Read carefully before pump installation

## CONTENTS

	Page
Introduction .....	2
Usage of a barrier chamber system (option codes BS1/BS3) .....	2
Replacement of the barrier liquid .....	3
Spare part lists and exploded views of the different pump series .....	4
E-Series .....	4
Chemicor .....	6
Biocor .....	7
Wiring diagram sensor/controller .....	8

## INTRODUCTION

**This manual merely serves as an addition to the manual for the pumps of the E-Series, Chemicor and Biocor. Each person working on the ALMATEC air-operated diaphragm pumps concerning installation, start-up, handling or maintenance has to read this annex and in addition the standard pump manual completely and in an attentive way and has to follow all mentioned procedures and safety notes.**

## USAGE OF A BARRIER CHAMBER SYTEM (option codes BS1/BS3)

The ALMATEC Barrier Chamber System is designed comply with high safety standards and is available for the ALMATEC pumps of the E-Series, Chemicor and Biocor series. It can be supplied in two versions:

BS1 Barrier Chamber System with sensors, also applicable in Ex-zones as well

BS3 Barrier Chamber System complete with sensors and controllers, also applicable in Ex-zones as well

The single diaphragm is replaced by a tandem arrangement of two diaphragms and a barrier chamber of conductive PE in between. The barrier chamber is standard-wise filled with a non-conductive liquid (De-ionised water). On request the barrier chamber can also be filled with a conductive liquid (for instance a water-glycol-mixture). To ensure the correct transfer of the pressure from the driving air, the barrier chambers have to be filled completely. Therefore, they are monitored by liquid sensors. After loosening the plug the barrier liquid can be refilled.

In case a diaphragm breaks, the conductivity of the barrier liquid rises which is registered by the conductivity sensors. The minimum required conductivity of 22  $\mu$ S covers a wide range of media. Otherwise, the operating scheme can just be inverted - conductive barrier liquid and monitoring a decrease in conductivity. If so, the conductivity sensors have to be adjusted accordingly. A tuning screw at the front side of the sensor allows its adjustment to a conductive barrier liquid. Attention: It must be considered, that the usage of a highly conductive barrier liquid the sensitivity of the systems is strongly reduced.

The filling sensors installed react on both conductive and non-conductive barrier liquids, therefore these need not be adjusted to the liquid.

The sensors can be connected to either controllers available on site (code BS1) or to the controllers supplied with the pump code BS3. A wiring diagram and technical data can be found on the controllers themselves as well as on the following pages. For further details, please refer to the data of the manufacturer of the components. The controllers have to be connected according to the valid guidelines and have to be installed in a suitable cabinet.

The max. permitted operation temperature for pumps equipped with a barrier chamber system is limited to 70°C for pumps made of PE and 80°C for pumps made of PTFE.

### **Replacement of the barrier liquid**

After using for some time the De-ionised water can be polluted with germs that may have an influence on the liquid's conductivity. In this case the water needs to be replaced.

To replace the barrier liquid, the housing bolts of the pump must be loosened (see disassembly remarks of the pump manual for details) until the diaphragms can be lifted off the barrier chamber with a thin tool without sharp edges. This allows to empty the barrier chamber completely. In case the barrier fluid has been contaminated by the fluid pumped, the relating safety measures according to the safety data sheet have to be respected. It must be made sure that the barrier chamber is free of residues before refilling. If necessary, the barrier chamber must be taken out for cleaning and rinsing. After the pump is reassembled (see pump manual for assembly advises tightening torques for the housing bolts), the refill has to be carried out using the filling hole normally closed by the plug and the O-ring. It is neither recommended nor sensible to empty the barrier chamber via the filling hole, as remains of fluid would stay within the system.

## SPARE PART LISTS AND EXPLODED VIEWS OF THE DIFFERENT PUMP SERIES

### E-Series: E10 / E15 / E25 / E40 / E50

Pump size					E 10	E 15	E 25	E 40	E 50
Code	Item	Pc	Description	Material	Part-No.	Part-No.	Part-No.	Part-No.	Part-No.
BS1	5	4	Sleeve, barrier chamber, code E..	PE	-	2 15 112 51	2 25 112 51	2 40 112 51	2 50 112 51
			Sleeve, barrier chamber, code F..	PE conductive	-	2 15 112 55	2 25 112 55	2 40 112 55	2 50 112 55
			Sleeve, barrier chamber, code T..	PTFE	2 10 112 69	2 15 112 69	2 25 112 69	2 40 112 69	2 50 112 69
			Sleeve, barrier chamber, code U..	PTFE conductive	2 10 112 68	2 15 112 68	2 25 112 68	2 40 112 68	2 50 112 68
	19	*	Housing bolt, barrier chamber, cpl.	1.4305	7 10 120 22	7 15 120 22	7 25 120 22	7 40 120 22	7 50 120 22
	21	2	Set screw, shaft, barrier chamber	1.4305	-	9 10 223 22	9 12 224 22	9 16 225 22	9 20 226 22
	39	2	Spacer	PETP	2 10 078 84	2 15 078 84	2 25 078 84	-	-
	40	2	Spacer bolt	1.4301	2 10 079 22	-	-	-	-
	41	2	Barrier chamber	PE conductive	7 10 076 55	7 15 076 55	7 25 076 55	7 40 076 55	7 50 076 55
	42	2	Conductivity sensor	diverse	7 00 074 99	7 00 074 99	7 00 074 99	7 00 074 99	7 00 074 99
	43	2	O-ring, conductivity sensor	FKM	9 12 506 74	9 12 506 74	9 12 506 74	9 12 506 74	9 12 506 74
	44	2	Plug GPN 730	PA	730 R 1/4	730 R 1/4	730 R 1/4	730 R 1/4	730 R 1/4
	45	2	O-ring, plug	FKM	9 13 575 74	9 13 575 74	9 13 575 74	9 13 575 74	9 13 575 74
	46	2	Inner diaphragm	EPDM	1 10 231 72	1 15 131 72	1 25 131 72	1 40 131 72	1 50 131 72
47	2	Liquid sensor, Namur	diverse	1 00 673 99	1 00 673 99	1 00 673 99	1 00 673 99	1 00 673 99	
48	2	O-ring, liquid sensor	FKM	9 09 618 74	9 09 618 74	9 09 618 74	9 09 618 74	9 09 618 74	
BS3	-	1	as BS 1, but with: Level controller	diverse	1 00 370 99	1 00 370 99	1 00 370 99	1 00 370 99	1 00 370 99
	-	1	Conductivity controller	diverse	1 00 175 99	1 00 175 99	1 00 175 99	1 00 175 99	1 00 175 99

\* E 10: 4 pieces; E 15 and E 25: 6 pieces; E 40 and E 50: 8 pieces



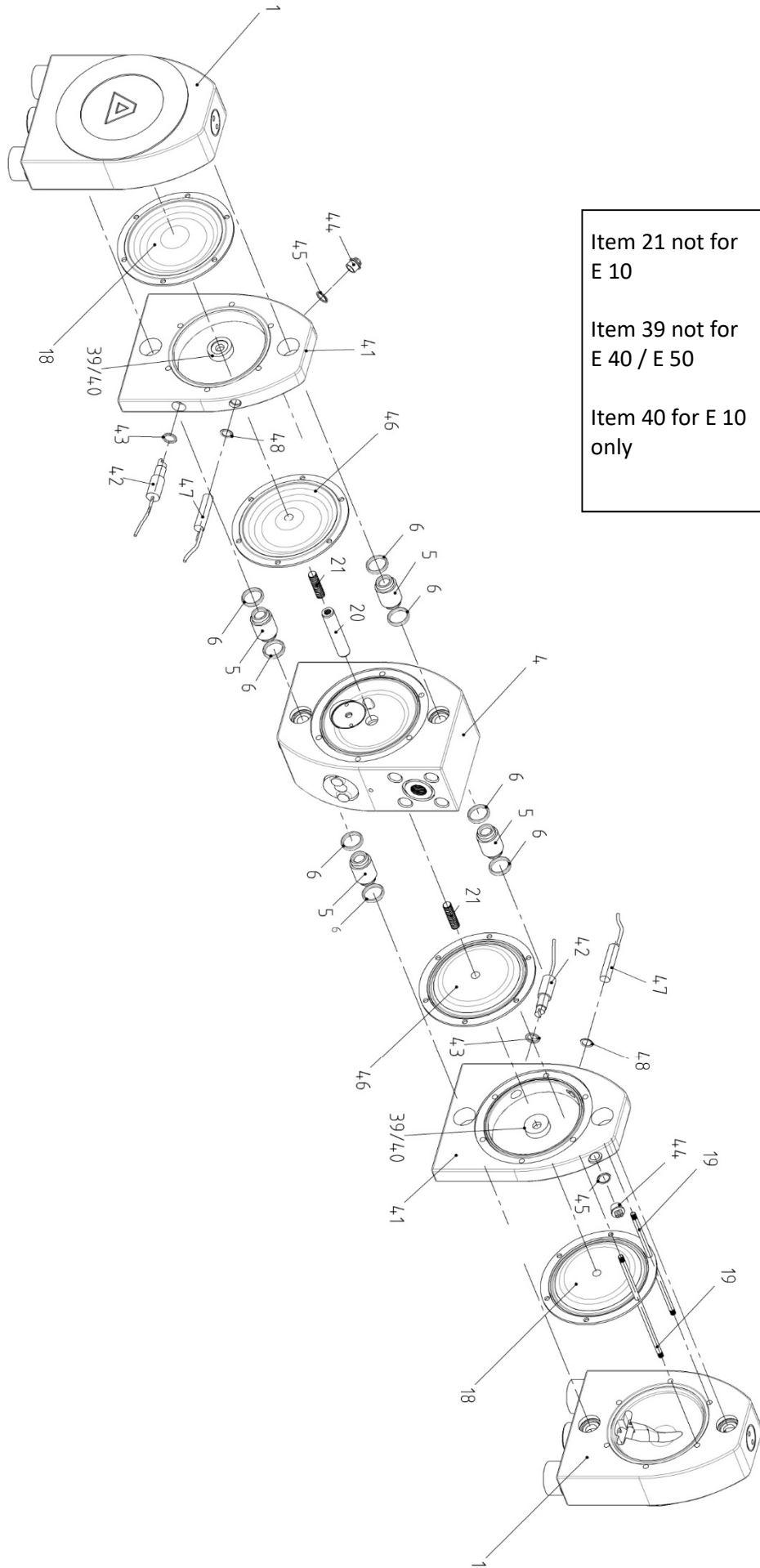

## Chemisor Series: AD20 / AD32 / AD50

Pump size					AD 20	AD 32	AD 50
Code	Item	Pc.	Description	Material	Part-No.	Part-No.	Part-No.
BS 1	8	*	Housing bolt, separation chamber, cpl.	1.4305	5 20 920 22	5 32 920 22	5 50 920 22
	13a	2	Set screw, shaft, barrier chamber	1.4305	9 10 223 22	9 12 224 22	9 16 225 22
	37	2	Separation chamber ring	PE-leitfähig	5 20 976 55	5 32 976 55	5 50 976 55
	38	4	O-ring, plug	EPDM	9 03 509 72	9 03 509 72	9 03 509 72
	39	4	Plug	PA	1 10 077 53	1 10 077 53	1 10 077 53
	40	4	Port extension	1.4571	5 20 913 24	5 32 913 24	5 50 913 24
	41	4	O-ring, ports, inside (code .E.)	EPDM	9 24 537 72	9 36 539 72	9 54 542 72
			O-ring, ports, inside (code .N.)	NBR	9 24 537 71	9 36 539 71	9 54 542 71
			O-ring, ports, inside (code .T.)	PTFE	9 24 537 60	9 36 539 60	9 54 542 60
	42	4	O-ring, ports, outside	EPDM	9 28 512 72	9 42 540 72	9 62 543 72
	43	2	Inner diaphragm	EPDM	1 15 131 72	1 25 131 72	1 40 131 72
	44	2	Liquid sensor	diverse	1 00 673 99	1 00 673 99	1 00 673 99
	45	2	O-ring, liquid sensor	FKM	9 09 618 74	9 09 618 74	9 09 618 74
	47	2	Spacer	PETP	2 15 078 84	2 25 078 84	-
	48	2	Conductivity sensor	diverse	7 00 074 99	7 00 074 99	7 00 074 99
	49	2	O-ring, conductivity sensor	FKM	9 12 506 74	9 12 506 74	9 12 506 74
BS 3		1	as BS 1, but with:				
	-		Level controller	diverse	1 00 370 99	1 00 370 99	1 00 370 99
	-	1	Conductivity controller	diverse	1 00 175 99	1 00 175 99	1 00 175 99

\* Für AD 20 und AD 32: 6 Stück; für AD 50: 8 Stück je Pumpe

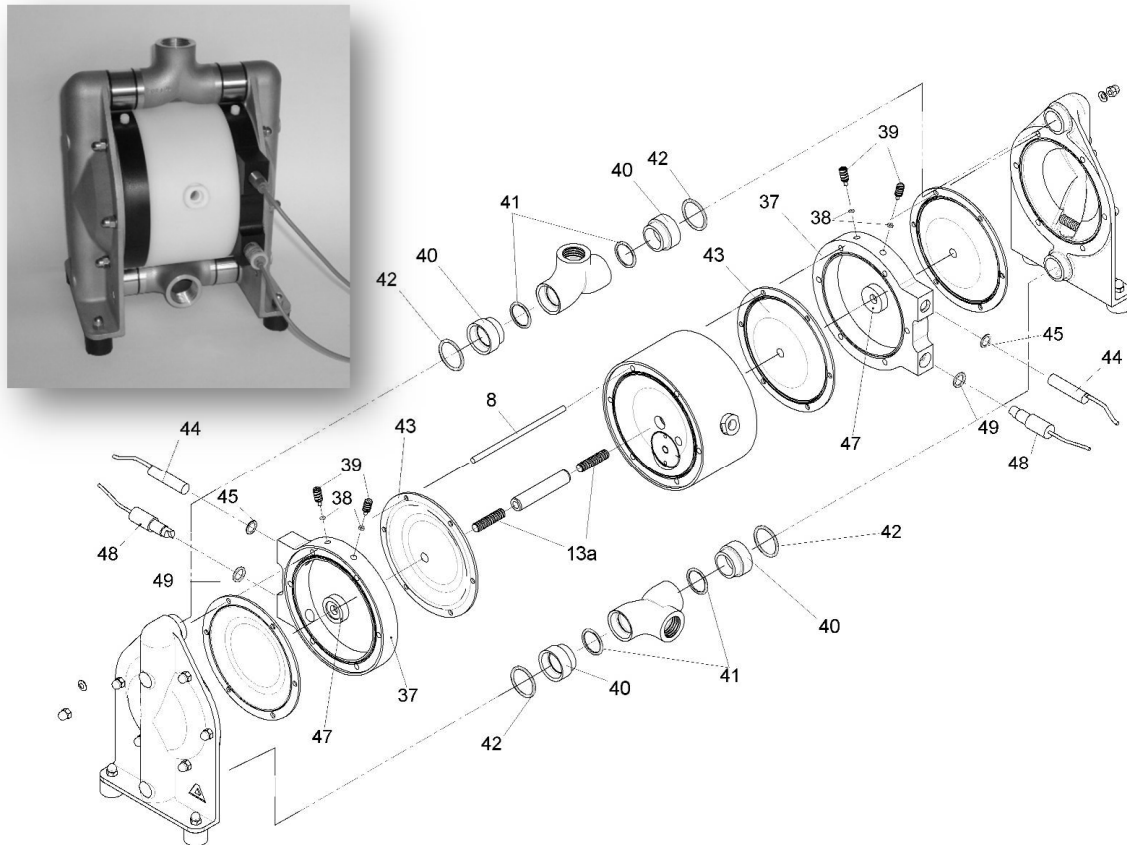

**Biocor Series: B20 / B 32**

Pump size					B 20	B 32
Code	Item	Pc.	Description	Material	Part-No.	Part-No.
BS1	13	1	Shaft	1.4301	2 15 330 22	5 32 245 22
	14	2	Set screw, shaft, barrier chamber	1.4305	9 10 223 22	9 12 224 22
	20	1	Center block	PE conductive	1 15 240 55	1 25 240 55
	22	1	PERSWING P® air control system, cpl.	PETP	2 15 001 84	2 15 001 84
	40	2	Barrier chamber ring	PE conductive	5 20 876 55	5 32 876 55
	43	2	Conductivity sensor	diverse	7 00 074 99	7 00 074 99
	43a	4	O-ring, conductivity sensor	FKM	9 12 506 74	9 12 506 74
	44	4	O-ring, plug	EPDM	9 03 509 72	9 03 509 72
	45	2	Plug	PA	1 10 077 53	1 10 077 53
	46	2	Inner diaphragm	EPDM	1 15 131 72	1 25 131 72
	47	2	Spacer	PETP	5 20 178 84	-
	48	2	Liquid sensor	diverse	1 00 673 99	1 00 673 99
	49	2	O-ring, liquid sensor	FKM	9 09 618 74	9 09 618 74
	BS3			as BS 1, but with:		
-		1	Level controller	diverse	1 00 370 99	1 00 370 99
-		1	Conductivity controller	diverse	1 00 175 99	1 00 175 99

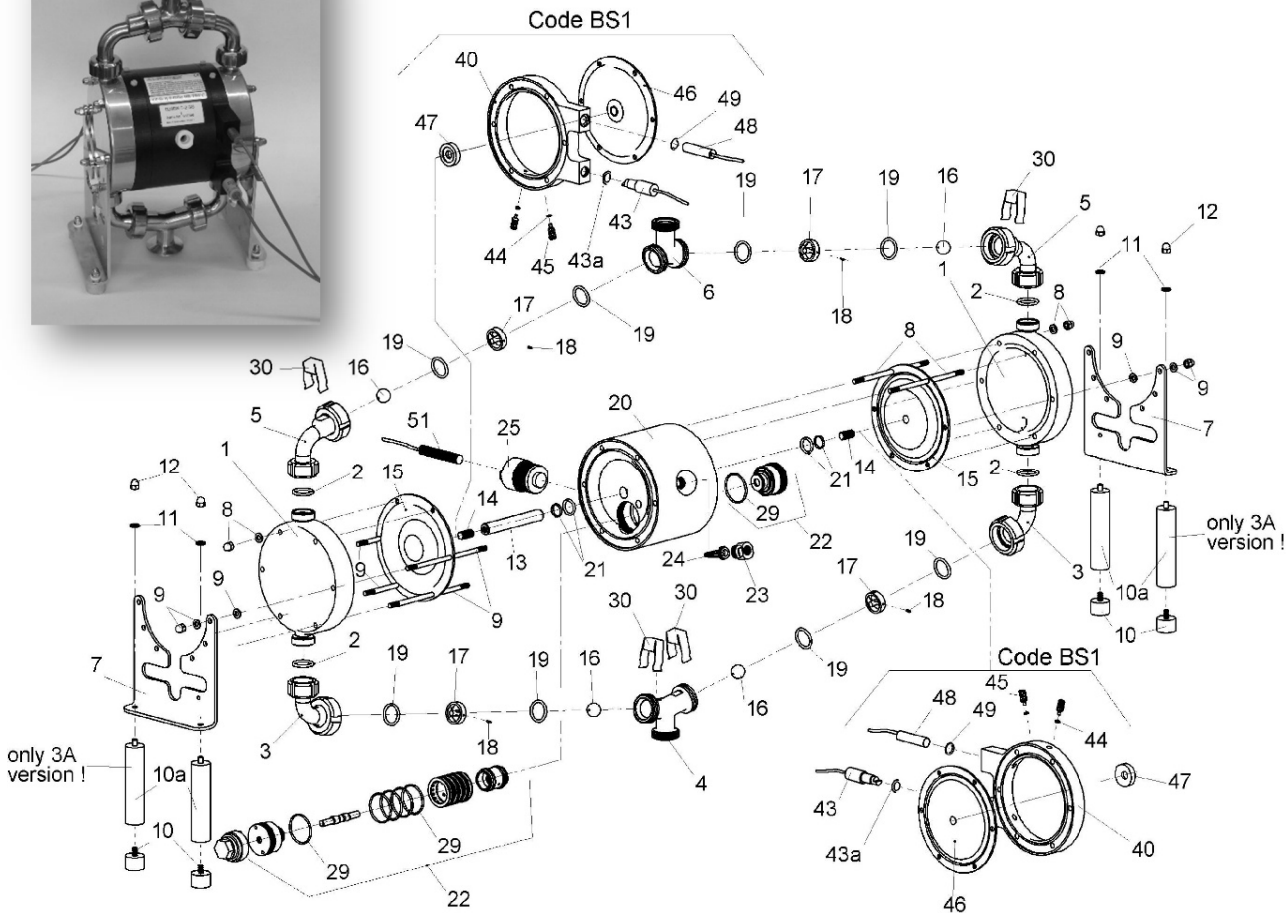

## WIRING DIAPHRAGM SENSOR / CONTROLLER



**Filling sensor**

**Part-No.:**  
1 00 673 99



**Conductivity sensor**

**Part-No.:**  
7 00 074 99

**brown = Plus**  
**blue = Minus**

**brown = Plus**  
**blue = Minus**

**Connections to level controller**  
**N-132/2-01**

Sensor 1:  
Clamp 10 = Plus  
Clamp 11 = Minus

Sensor 2:  
Clamp 14 = Plus  
Clamp 15 = Minus

Voltage:  
230 V AC / 115 V AC  
Clamp 9 = N  
Clamp 7 = L

**Connections to conductivity controller**  
**FTW 325**

Sensor 1:  
Clamp 9 = Plus  
Clamp 7 = Minus

Sensor 2:  
Clamp 8 = Plus  
Clamp 7 = Minus

Voltage:  
230 V AC  
Clamp 2 = N  
Clamp 1 = L



Subject to change without notice, 01/2018

**ALMATEC Maschinenbau GmbH**  
Carl-Friedrich-Gauss-Str. 5 · 47475 Kamp-Lintfort · Germany  
Telephone ++49.2842.9610 · Telefax ++49.2842.96140  
<http://www.almatec.de> · e-mail: [info@almatec.de](mailto:info@almatec.de)