

Installation, Operation & Maintenance Manual

Models: E02, E05, E12, E25, E75, E125

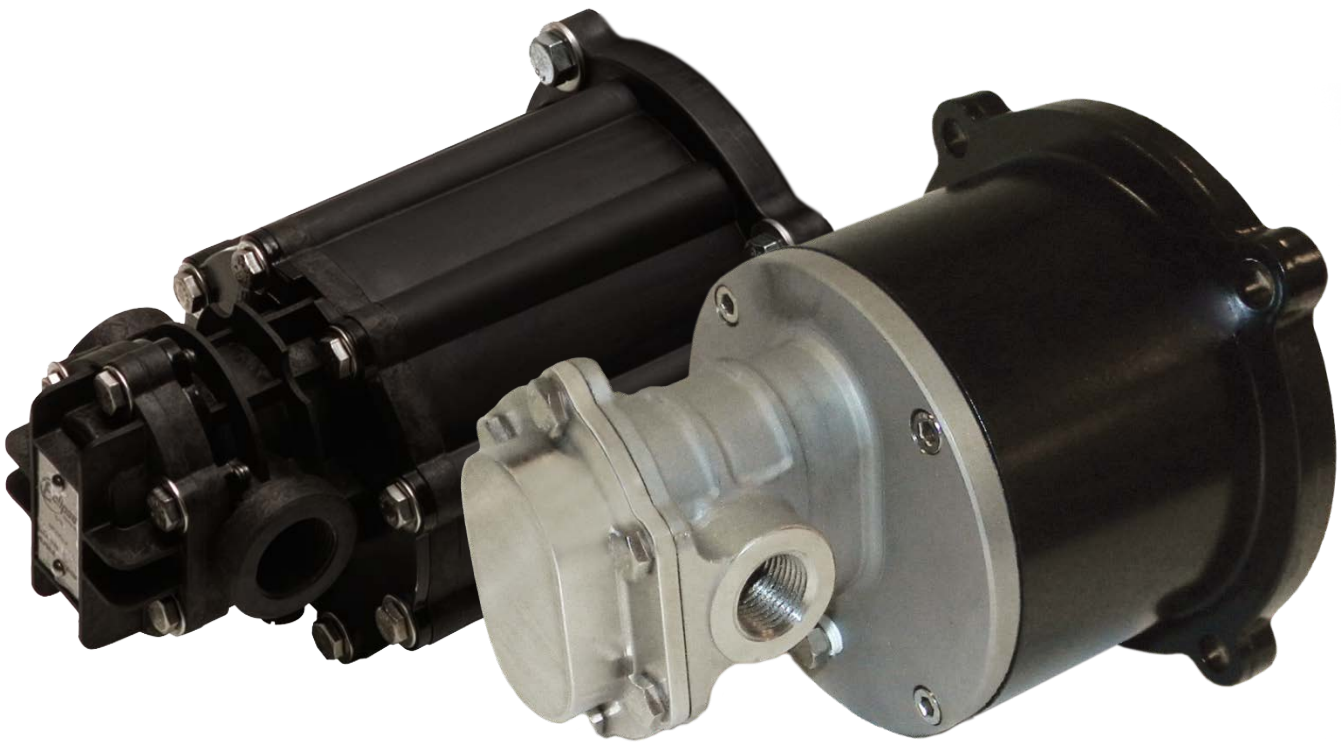

Bulletin: IOM-ECL-3500 Rev I

ECLIPSE[®]
EXTERNAL GEAR
METERING PUMP

Pulsafeeder® Factory Service Policy

Should you experience a problem with your Eclipse pump, first consult the troubleshooting guide in this installation, operation and maintenance manual. If the problem is not covered or cannot be solved, please contact your local Pulsafeeder Distributor or our Technical Services Department for further assistance.

Trained technicians are available to diagnose your problem and arrange a solution. Solutions may include purchase of replacement parts or returning the unit to the factory for inspection and repair. All returns require a Return Authorization number to be issued by Pulsafeeder. Parts purchased to correct a warranty issue may be credited after an examination of original parts by Pulsafeeder. Warranty parts returned as defective, which test good, will be sent back freight collect. No credit will be issued on any replacement electronic parts.

Any modifications or out-of-warranty repairs will be subject to bench fees and costs associated with replacement parts.

Pulsafeeder's Factory Service Policy is maintained online. Please source this document at this URL: <http://www.pulsa.com/pulsa-docs/Pulsafeeder-EPO-Limited-Warranty-Statement.pdf>

Warranty

Pulsafeeder warrants its Eclipse products to be free of defects in material and workmanship under normal use and service for a period of one year from the date of shipment from Pulsafeeder's factory in Rochester, New York, USA. Any modifications or out-of-warranty repairs will be subject to bench fees and costs associated with replacement parts.

Trademarks

Eclipse® is a registered trademark of Pulsafeeder, Inc.

Pulsafeeder® is a registered trademark of Pulsafeeder, Inc.

Viton® is a registered trademark of DuPont Performance Elastomers L.L.C.

Kalrez® is a registered trademark of E.I. du Pont de Nemours and Company.

Kynar® is a registered trademark of Arkama, Inc.

Copyright ©2005/2006 Pulsafeeder Inc. All rights reserved.

Information in this document is subject to change without notice. No part of this publication may be reproduced, stored in a retrieval system or transmitted in any form or any means electronic or mechanical, including photocopying and recording for any purpose other than the purchaser's personal use without the written permission of Pulsafeeder Inc.

Conventions

The following Conventions are used in this document.



A WARNING DEFINES A CONDITION THAT COULD CAUSE DAMAGE TO BOTH THE EQUIPMENT AND THE PERSONNEL OPERATING IT. PAY CLOSE ATTENTION TO ANY WARNING.



Notes are general information meant to make operating the equipment easier.

Revision History

- Rev A Release Date August 2005, first revision
- Rev B Release Date December 2005
Updates and corrections to various text throughout
New *figure 47* showing motor adapter
Update Specifications and add information on page 44
Update BOM, all models
Add motor rotation vs. flow direction diagram (*figure 2b*)
Add O-ring reference chart (*Section 18*)
- Rev C/C2 Release Date December 2006
Added new information for model E10
Updated flow curves for all models
Minor updates to Specification pages, remove KalRez O-ring options
- Rev D Release December 2006
Model E10 now upgraded to E12, new flow curves, update text
- Rev E Release May 2009
Model E125 added, new flow curves, update text
- Rev F Release June 2012
Eclipse Hypo Series added, updated text and pictures
Updated KOPkits to new part number format
- Rev G Release September 2014
Updated parts listing and removed the Tefzel housings
- Rev H Release March 2015
Updated branding, release Eclipse Metallic, updated flow curves
- Rev I Release May 2016
Updated Eclipse Metallic content, diagrams, and organization.

Table of Contents

PULSAFEEDER® FACTORY SERVICE POLICY.....	I
TRADEMARKS	I
CONVENTIONS	I
1. INTRODUCTION	1
1.1 General Description	1
1.2 Safety Considerations	2
1.3 Liability Exclusions	2
1.4 Handling and Lifting	2
1.5 Recycling and End of Product Life	3
2. EQUIPMENT INSPECTION AND STORAGE	3
3. ATEX DIRECTIVE 2014/34/EU	4
4. INSTALLATION	10
4.1 General Installation.....	10
4.2 Pump Orientation and Motor Direction	11
5. EQUIPMENT SETUP AND OPERATION	12
6. MAINTENANCE OVERVIEW	13
6.1 Recommended Spares - KOPkits.....	13
6.2 Maintenance Precautions for Magnet-driven Equipment:	14
ECLIPSE NON-METALLIC PUMPS	15
7. DISASSEMBLY/ASSEMBLY, ECLIPSE 02 NON-METALLIC	15
7.1 Disassembly	15
7.2 Assembly	18
8. DISASSEMBLY/ASSEMBLY, ECLIPSE 05/12 AND ECLIPSE	23
25 NON-METALLIC	23
8.1 Disassembly	23
8.2 Assembly	26
9. DISASSEMBLY/ASSEMBLY, ECLIPSE 25/75/125 NON-METALLIC	30
9.1 Disassembly	30
9.2 Assembly	34
10. PUMP MODEL IDENTIFICATION – NON-METALLIC	40
10.1 KOPkit Part Number Identification – Non-Metallic	41
11. PARTS DIAGRAM AND LIST, ECLIPSE 02 NON-METALLIC.....	42
12. PARTS DIAGRAM AND LIST, ECLIPSE 05 NON-METALLIC	45
13. PARTS DIAGRAM AND LIST, ECLIPSE 12 NON-METALLIC.....	48
14. PARTS DIAGRAM AND LIST, ECLIPSE 25 NON-METALLIC.....	51
15. PARTS DIAGRAM AND LIST, ECLIPSE 75 NON-METALLIC.....	55
16. PARTS DIAGRAM AND LIST, ECLIPSE 125 NON-METALLIC	59
ECLIPSE METALLIC PUMPS.....	63
17. DISASSEMBLY/ASSEMBLY, ECLIPSE 02.....	63
17.1 Disassembly	63
17.2 Assembly.....	66
18. DISASSEMBLY/ASSEMBLY, ECLIPSE 05/12 AND ECLIPSE.....	69
25 METALLIC 69	
18.1 Disassembly.....	69
18.2 Assembly.....	73
19. DISASSEMBLY/ASSEMBLY, ECLIPSE 75/125 METALLIC.....	77
19.1 Disassembly.....	77
19.2 Assembly.....	79
20. PUMP MODEL IDENTIFICATION – METALLIC.....	83
20.1 KOPkit Part Number Identification - Metallic	84
21. PARTS DIAGRAM AND LIST, ECLIPSE 02 METALLIC.....	85

22. PARTS DIAGRAM AND LIST, ECLIPSE 05 METALLIC.....	88
23. PARTS DIAGRAM AND LIST, ECLIPSE 12 METALLIC.....	91
24. PARTS DIAGRAM AND LIST, ECLIPSE 25 METALLIC.....	94
25. PARTS DIAGRAM AND LIST, ECLIPSE 75 METALLIC.....	97
26. PARTS DIAGRAM AND LIST, ECLIPSE 125 METALLIC.....	100
27. INSPECTION AND WEAR LIMITS	103
27.1 Service and Replacement Limits	104
28. TROUBLESHOOTING	105
29. SPECIFICATIONS	107
29.1 General Specifications	111
29.2 Torque Specifications.....	112
30. DIMENSIONAL DRAWINGS	113
30.1 Eclipse 02 Non-Metallic	113
30.2 Eclipse 02 Metallic	114
30.3 Eclipse 05 Non-Metallic	115
30.4 Eclipse 05 Metallic	116
30.5 Eclipse 12 Non-Metallic	117
30.6 Eclipse 12 Metallic	118
30.7 Eclipse 25 Non-Metallic	119
30.8 Eclipse 25 Metallic	120
30.9 Eclipse 75/125 Non-Metallic	121
31. PERFORMANCE CURVES.....	122
31.1 Eclipse02.....	122
31.2 Eclipse 05.....	123
31.3 Eclipse 12.....	124
31.4 Eclipse 25.....	125
31.5 Eclipse 75.....	126
31.6 Eclipse 125.....	127

1. Introduction

1.1 General Description

Pulsafeeder's Eclipse Series pumps safely handle hazardous, highly corrosive, explosive or toxic chemicals. The Eclipse Series pumps provide safe, leak-free service because the magnetic coupling eliminates the need for traditional sealing methods, such as mechanical seals or packing.

Eclipse Series external gear pumps mount to standard NEMA 56C, 143/145TC and 182/184TC motors and IEC 63, 80, 100 and 112 B3/B14 metric flanged (C-face) motors. This enables the pumps to be close coupled, which provides greater assembled strength, completely isolated enclosure of all moving parts, and compact design. This also eliminates the need for special base plate mounting, shaft couplings and guards, complicated drives, and pump bearing lubrication and maintenance, while minimizing plant real estate for optimum pump installation.

All Eclipse Series pumps transmit rotational torque from the motor shaft to the pump shaft by means of a magnetic drive coupling. A drive magnet assembly attached to an electric motor shaft rotates around a closed end containment shell or "containment can" which seals against the pump center housing with a static o-ring. Inside the can an encapsulated driven magnet assembly is mounted on the end of the pump shaft. As the drive magnet assembly rotates, lines of magnetic flux or force cause the driven magnet assembly to rotate which causes the pump shaft to rotate.

All magnetic drive couplings are designed for satisfactory operation of the pump. The magnetic couplings have an integral safety feature that allows them to "decouple" if the coupling torque limit is exceeded. This situation might occur if foreign material were to jam the pump gears or if unusually high torque was developed on pump start-up. Eclipse Series pumps use permanent rare earth Neodymium Iron magnets that can run decoupled without losing their magnetic strength provided magnet temperatures do not exceed 450°F (232°C).



If the pump is allowed to run dry for an extended period of time decoupled, high temperatures could be generated through opposing magnetic forces that ultimately would cause the loss of magnetic strength.

Eclipse Series pumps feature continuous operation over wide temperature and pressure variations, constant volume pulsation free flow, the ability to handle wide viscosity variations, and ease of inspection and maintenance. Specific limitations are covered in this manual and summarized in **Section 11** Specifications.

To achieve successful operation and maximum life from your pump, make sure that the pump selection and materials are compatible with the service and operating conditions of your application.

Pumping fluids containing abrasives should be avoided, as accelerated pump wear will result. Eclipse Series gear pumps are designed to handle clear fluids at varying viscosities. Reference the performance curves in **Section 20** for specific values.



IT IS NOT RECOMMENDED TO ALLOW THE PUMP TO RUN DRY. THIS CAN CAUSE EXCESSIVE PUMP WEAR OR FAILURE.

1.2 Safety Considerations

The Eclipse series pumps yield both mechanical and hydraulic capabilities. In consideration of safety, the user should be mindful of the following considerations in regards to personal, nearby personnel, and environmental safety. Please consider the following prior to the installation and operation of an Eclipse pump.

1. Read and understand all related instructions and documentation before attempting to install or maintain this equipment.
2. Observe all special instructions, notes, and cautions.
3. Act with care and exercise good common sense and judgment during all installation, adjustment, and maintenance procedures.
4. Ensure that all safety and work procedures and standards that are applicable to your company and facility are followed during the installation, maintenance, and operation of this equipment.
5. As a positive displacement pump, an Eclipse Series pump will continue to build pressure if the fluid pathway is closed or blocked and can result in excessive and unsafe casing pressure or pump failure.



ECLIPSE SERIES PUMPS CONTAIN POWERFUL MAGNETS; PLEASE USE EXTREME CAUTION IN AREAS WHERE MAGNETS ARE IDENTIFIED. THESE MAGNETS CAN BE HARMFUL TO PACEMAKERS, CELL PHONES, CREDIT CARDS & LAPTOPS. THE RECOMMENDED DISTANCE TO MINIMIZE IMPACT IS AT LEAST 3 FEET (1 METER). STAY AT LEAST 20 FEET (6 METERS) AWAY IF YOU HAVE A PACEMAKER.



NEVER PLACE FINGERS OR HANDS INTO ANY PART OF THE PUMP WHILE THE PUMP IS RUNNING.

1.3 Liability Exclusions

Pulsafeeder, Inc. is unable to monitor the observance of the instructions given in this manual, nor verify the actual working conditions and installation of the equipment, the correct operation and maintenance of the equipment and accessories. An incorrect installation, or misuse of the equipment, may cause serious damage and may pose a danger to persons or property. Any anomalies must be reported to the maintenance supervisor. The user is not authorized to tamper with the machine for any reason.



ATTEMPTS TO DISASSEMBLE, MODIFY OR TAMPER IN GENERAL BY UNAUTHORIZED PERSONNEL WILL VOID THE GUARANTEE AND WILL RELEASE PULSAFEEDER, INC. FROM ANY LIABILITY FOR DAMAGE CAUSED TO PERSONS OR PROPERTY RESULTING FROM SUCH ACTIONS.

Pulsafeeder, Inc. is considered released from any liability in the following cases:

- Improper installation
- Improper use of the equipment by non-professional or inadequately trained operators
- Use not in compliance with regulations in the Country of use
- Lack of maintenance or improperly performed
- Use of non-original spare parts or incorrect parts for the model in question
- Total or partial failure to observe the instructions
- Exceptional environmental events

1.4 Handling and Lifting

Boxes, crates, pallets or cartons may be unloaded using fork lift vehicles or slings dependent on their size and construction. A crane must be used for all pumps in excess of 25 kg (55 lb). Fully trained personnel must carry out lifting, in accordance with local regulations. Slings, ropes and other lifting gear should be positioned where they cannot slip and where a balanced lift is obtained.

1.5 Recycling and End of Product Life

At the end of the service life of an Eclipse pump or its parts, the materials and parts should be recycled or disposed of using an environmentally acceptable method and following all local requirements. If the product contains substances that are harmful to the environment, these should be removed and disposed of in accordance with current regulations. This also includes the liquids and/or gases that may be used in the "seal system" or other utilities.

Make sure that hazardous substances are disposed of safely and that the correct personal protective equipment is used. The safety specifications must be in accordance with the current regulations at all times.

2. Equipment Inspection and Storage

 **NOTE** Check all equipment for completeness and accuracy against the order and for any evidence of shipping damage. Shortages or damage should be reported immediately to the freight carrier and to your Pulsafeeder representative or distributor.

Storage of an Eclipse pump for up to 12 months is considered short term. The recommended storage procedures are:

- Leave pump in original shipping carton.
- Store indoors in a dry ambient atmosphere. Avoid temperature variations.
- Leave all shipping plugs in place.
- Contact the motor manufacturer for specific motor storage information.

These instructions should be read carefully by the personnel responsible for installation, operation and maintenance of the equipment and kept in a convenient place for ready reference. It is recommended that a copy of the order documents be kept with this manual as well as a written record of the pump model and serial number, which is on the nametag attached to the pump.

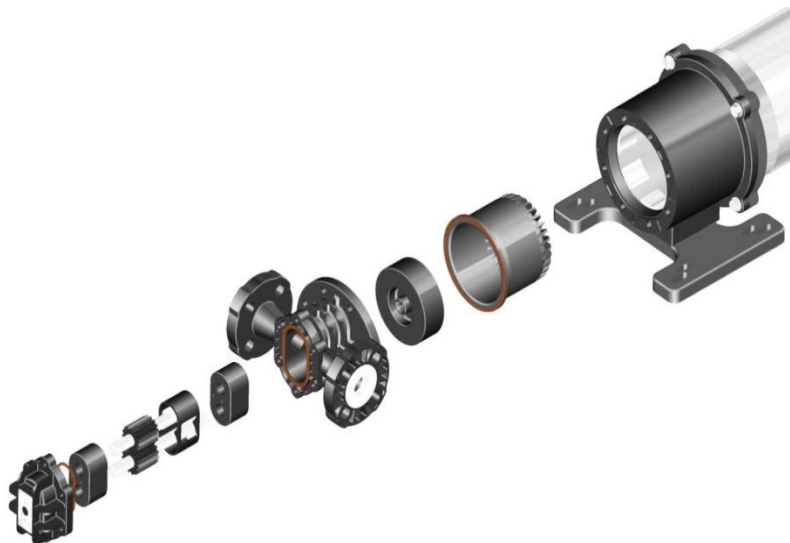

Figure 1 – Parts view of a Non-Metallic E75/125

3. ATEX Directive 2014/34/EU

Eclipse IOM Addendum Potentially Explosive Atmospheres

NP550110-IOM REV D, pages 4 - 9

3/30/2016

Scope

This section of the Installation, Operation and Maintenance Manual includes all the necessary additional information to be considered when installing these pump models in a potentially explosive environments (Group II, Category 2, G & D).

Models included in the assessment

E, EH, CMD Series Eclipse Magnetically driven gear pumps

Description of Equipment

The general product description for this equipment is positive displacement external gear pumps. They are supplied as mechanically sealed and magnetically driven versions.

Intended Usage of the Equipment

Eclipse gear pumps are intended to be used to transfer various fluids. With proper sensors or feedback devices, they can also be used to meter fluids.

Pulsafeeder has decided to construct the pumps to meet the requirements for Group II, category 2 equipment. To meet Category 2 equipment requirements, all possible ignition sources that can occur in normal operation of the pumps and additionally, those that can become effective as a result of malfunctions expected to occur in service must be considered. As the pumps are not intended to meet the requirements of category I, potential ignition sources arising from rare malfunctions can be neglected.

Reference Standards

- 2006/42/EC – Machine Safety Directive
- 2014/34/EU – ATEX – Equipment Intended for Use in Potentially Explosive Atmospheres
- BS EN ISO 12100:2010 Safety of machinery - General principles for design – Risk assessment and risk reduction
- BS EN 1127-1:2011 Explosive atmospheres - Explosion prevention and protection – Part I: Basic concepts and methodology
- EN 60529 Degrees of protection provided by enclosures (IP Code)

Equipment

Equipment in Group II, Category 2, is intended for use in areas in which explosive atmospheres caused by gases, vapors, mists or air/dust mixtures are likely to occur.

G & D Atmospheres

- In G type Explosive atmosphere (Gas, vapor, mist) equipment is suitable for use in **Zone 1** areas.
- In D type Explosive atmosphere (Dust) equipment is suitable for use in **Zone 21** areas.

Temperature Class

Temperature class **TX** based on ambient and pumped fluid temperature. Different temperature classes can be achieved based on fluid and ambient temperatures (see chart).

Temperature Class and Maximum Liquid Temperatures

Temperature Class	Maximum Surface Temperature C Permitted (Dust)	Max. Liquid or Ambient Temperature C		Comments
		Sealed Pumps	Magnetic Drive	
T1	450	260	230	Fluid temperatures are limited by pump construction
T2	300	225	225	
T3	200	145	145	
T4	135	90	90	
T5	100	65	65	
T6	85	50	50	Normal class rating

* Maximum Temperature Class for Eclipse Series Pumps is T6.

Technical Support & Service

For technical support or service contact:
Pulsafeeder Inc.

2883 Brighton Henrietta Townline Road
Rochester, New York
14623
USA
(585) 292-8000

Protective Earth Ground Symbol

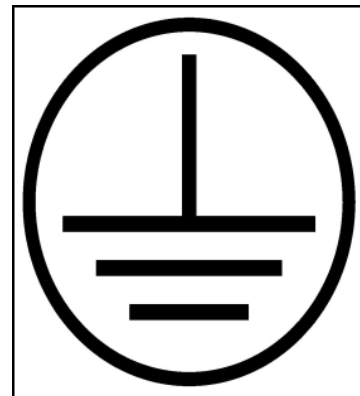

Sample Tag



II 2G TX II 2D TX
Tech. File Ref.: XXXXXXXX-XXX Mfg. Date: XX/XX/XX
Mfg. Location: Rochester, NY USA 14623-2909

Additional Equipment Recommended

Additional equipment such as a Power Monitor, Temperature probe and a Flow meter should be fitted at all times when using a pump in a potentially explosive atmosphere. The pump / unit must also be "Earth Grounded" at all times. (When an ATEX approved pump is requested, a "Ground" contact point is provided or identified by the protective earth ground symbol. The electrical installation must conform to all location relevant codes.

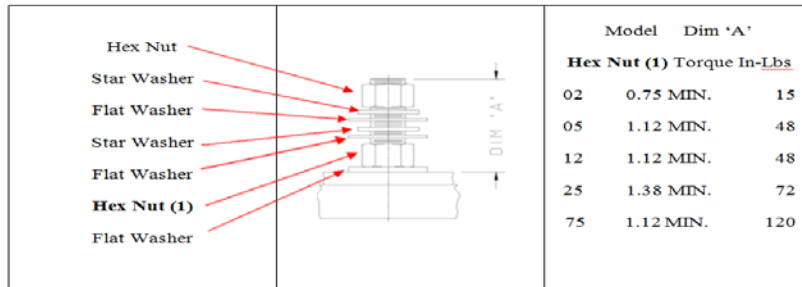

Figure A – Metallic Pump Grounding

A pump should never be "Run Dry" especially in Potentially Explosive Atmospheres.

General Usage Precautions

1. The pump must be "Earth Grounded" at all times to prevent Electrostatic charge build up. (When an ATEX approved pump is requested, a "Ground" contact point is provided or identified by the protective earth ground symbol. The electrical installation must conform to all location relevant codes.
2. The pump must not be used beyond its ratings and if the original operating conditions change, it is the users responsibility to check with Pulsafeeder if the pump is still acceptable for the new operating conditions.
3. Pulsafeeder will only consider the pump safe for the purpose and duty conditions originally specified by the purchaser. Pulsafeeder will not accept responsibility for pump failure or personal injury arising from miss-application of the product.
4. In the event of any one of the following conditions occurring the pump should be shut down and the cause investigated and rectified.
 - Unaccountable rise in discharge pressure
 - Release of liquid from the pressure relief mechanism
 - Excessive noise emissions
 - Unaccountable rise in operating temperature
 - Excessive power consumption
 - Loss of flow
5. Unauthorized modification or use of components other than original Pulsafeeder spares revokes any liability for consequences, which may result.
6. A pressure relief method must be used at the discharge of the pump to provide over pressure protection. For ATEX Potentially Explosive Atmospheres, a "Return to tank type piping system" is recommended to prevent high temperatures due to recycled fluid.
7. Pumps can not be driven by belts or chains.
8. Lubricate Power frames if used with the appropriate lubricant specified in the standard instructions.
9. Check any gear reducers, motor, couplings, etc for instructions and lubricate as recommended.
10. Packing should not be used in potentially explosive environments. Packing adjustment is critical to prevent high surface temperatures. Packing must leak to cool itself.

11. Care must be exercised on the initial start of a new pump to prevent dry running. The pump cannot tolerate dry run for more than a few seconds. Even after initial break in, pumps must not run dry as high temperatures can happen very quickly.
12. Inspecting the pump for internal wear regularly. Look for signs of heavy grooving, galling, twisting or breakage. These are the signs that rapid wear has taken place. This is a good indication that the pump may not be a good match for the service conditions. Rapid wear could result in unexpected failure that could be the source of ignition of the explosive environment.
13. The purchaser/user must ensure that all maintenance work including disassembly and reassembly is carried out by authorized and qualified personnel, who are sufficiently trained in the operation of the pump.
14. Due to the tight internal tolerances of a gear pump the most reliable way of repairing a pump is by the use of a Kopkit, which contains all the normal wear parts to restore the pump to like new condition.
15. Make sure that heavy deposits of dust are not allowed to accumulate. Clean pump periodically.
16. Don't run the pump faster or at a higher pressure than rated.
17. Don't flush the pump with steam or air without protecting against shaft rotation due to the gears in the pump being forced to turn like a turbine.
18. The use of a power, pressure and temperature monitoring of the pump and system is highly recommended.
19. Refer to the provided temperature table for information relating to ambient and fluid temperatures.
20. Properly vent or flush the pump of fluids or gasses before disassembling for service.
21. Obtain, read and keep maintenance instructions furnished with the pump.

Normal Operation

Potential Ignition Source	Measures to take to prevent the source from becoming effective
Frictional Ignition	<p>All moving parts in the pumps are submersed in the pumped fluid which acts as a lubricant and coolant. Do not run the pump dry.</p> <p>Packing is not recommended for Explosive environments due to the possibility of high temperature in the area of the stuffing box due to misadjustment. If packing is used, thermal monitoring is required to meet ATEX requirements</p>

Potential Ignition Source	Measures to take to prevent the source from becoming effective
Pump Bearings	<p>Verify pump turns freely</p> <p>The use of a strainer is recommended</p> <p>The use of bearing flushing is recommended</p> <p>The bearing housings need to be examined for signs of overheating, abnormal noise, or discoloration on a daily basis. Alternatively continuous temperature monitoring can be fitted and set to trip the drive power at 10 C above normal baseline temperature</p> <p>Monitor pump frequently when pumping non-lubricating fluids</p>
Power Frame Bearings	Check lubricant level weekly and monitor for leaks daily
Dust deposits on pump	Regular cleaning is needed to prevent deposits from accumulating in a thickness great enough to become an ignition hazard
Static electricity discharge	<p>The pump must be grounded (bonded) at the "Protective Earth Ground" location marked on the pump</p> <p>Vent cavities to prevent Oxygen / Air build up</p>
High Temperature	<p>Recommend Temperature monitors</p> <p>Recommend Flow indicator</p> <p>Recommend Power monitor</p> <p>Recommend Pressure switch</p>
Couplings	If a coupling is used, it must be ATEX approved for the environment
Reducers	If a reducer is used, it must be ATEX approved for the environment
Use of Electric Motor	If an electric motor is used as a driver for the pump, it must be ATEX approved for the environment

Expected Malfunction

<p>Potential Ignition Source</p>	<p>Measures to take to prevent the source from becoming effective</p>
<p>Dry Run</p>	<p>All moving parts in the pumps are submersed in the pumped fluid which acts as a lubricant and coolant. Do not run the pump dry.</p> <p>Recommend Power monitor Recommend Flow indicator Recommend Pressure switch Recommend Temperature monitors</p>
<p>Pump Bearings</p>	<p>Max. radial wear on bearings is .13 mm (.005 in) Monitor pump daily when pumping non-lubricating fluids for high temperatures at bearing bosses Every 1000 hours inspect the pump for wear and rebuild with a Kopkit if necessary Typical life of the pump bearings is 2000 hours. Regular maintenance and good record keeping will provide a more accurate service interval</p>
<p>Power Frame Bearings</p>	<p>Check condition of lip seals for the power frame every month to insure lubricant containment</p>
<p>High Temperature</p>	<p>Recommend Temperature monitors Recommend Flow indicator Recommend Pressure switch Recommend Power monitor</p>

4. Installation



Pump installation site should provide easy access for routine maintenance and protect the pump from environmental elements and from leaks or drips from nearby process equipment.

4.1 General Installation

See Figure 2a for typical installation diagram and **Section 4.1.1** for recommended accessories.

- Keep suction piping system short and straight to minimize friction loss to the pump. Make sure that the pump will not run dry. Flooded suction or gravity fed fluid to pump inlet is preferred.
- Arrange all suction piping and fittings to prevent formation of air pockets. Make sure all joints are airtight.
- Flush and blow out all suction lines prior to mating to pump. Use nipples and unions on both the suction and discharge sides of the pump for ease of maintenance.
- Do not force, bend, or spring either suction or discharge piping when mating up to the pump. Use supports or hangers at intervals as required in an effort to compensate for piping strain due to vector forces and bending forces. When necessary, install thermal expansion joints or accessories so minimal piping strain is placed upon the pump.
- If flexible suction lines are used, be sure their selection and installation will prevent wall collapse which will result in a starved suction condition.
- When taking suction from a tank or vessel, avoid entry of sludge or solids into suction line by placing suction line inlet above maximum expected level of solids.
- Discharge lines should be fitted with a properly sized pressure relief valve to protect both pump and discharge system. The pressure relief valve outlet should be piped back to the supply tank.

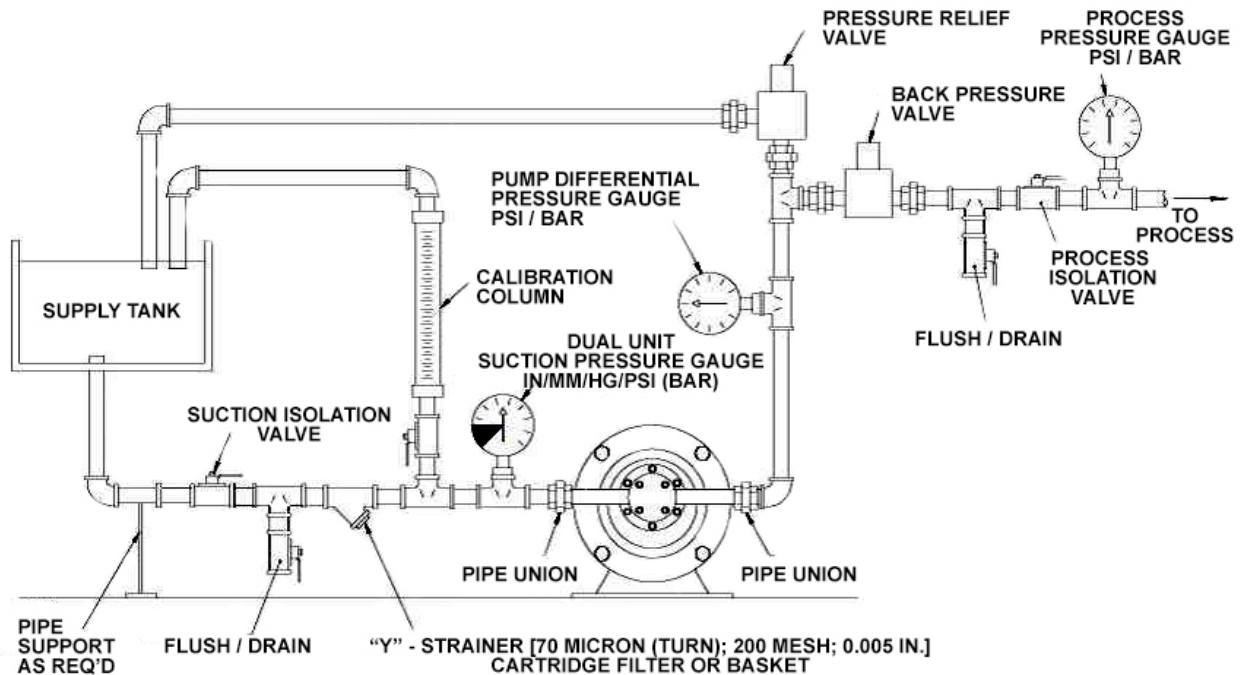

Figure 2a – General Installation

4.1.1 Recommended Accessories

- 70 micron Y strainer
 - Dual unit gage (Hg / psi)
 - Differential pressure gage
 - Pressure relief valve (field adjustable)
 - Back pressure valve (field adjustable)
- If start-up screens are used be sure they do not clog and starve suction. Start-up screens should be removed prior to placing system into regular operation.
 - Installation of vacuum and pressure gauges in the suction and discharge piping is recommended to properly monitor system operation.
 - When a by-pass system is used to control flow from the pump, the bypassed fluid should be piped back to the supply source to prevent heat build-up due to recirculation cavitation. If it is absolutely necessary to pipe by-pass back to the pump suction line, the point of entry should be at least ten times the diameter of the suction pipe away from the suction inlet. Provision for cooling should be made in the event of excessive heat buildup through fluid recirculation.
 - Use only full-bore ball valves or gate valves in the suction piping. If suction strainers are used, select a size to minimize pressure drop and can be easily cleaned and maintained.
 - The pump is designed to self-prime if fluid is supplied at the pump inlet. If foot valves are used, flapper type valves are recommended and should be sized to minimize friction loss.
 - Back pressure valves provide a known, continuous, pressure to the pump. This improves flow stability, measurement, and regulation.



Failure to install and properly set a pressure relief valve (according to manufacturer's specifications) can lead to pump failure and unsafe operating conditions.

4.2 Pump Orientation and Motor Direction

- Bolt the pump motor down firmly to mounting surface. Provide for air movement and circulation over electric motor to enhance proper cooling.
- Direction of flow is dependent on direction of motor rotation. Reversing the motor direction, and therefore the drive shaft rotation direction, reverses flow. This will also change which port is the suction and which is the discharge, see Figure 2b. Since the Eclipse Series pumps can be installed both horizontally (standard) and vertically, it is very important to identify the suction pipe connection which will determine the required motor rotation.
- Wire the motor in accordance with local, national, and motor manufacturer requirements.
- When installed horizontally, make sure the pump housing drain is on the bottom of the pump. If the pump is installed with the drain facing upwards, the rotation of the motor will be incorrect and either needs to be reversed or the pump orientation corrected. Reference the pump drawings in **Section 19** for drain location. If the pump is mounted vertically, the drain plug will be on the left or right side of the pump.

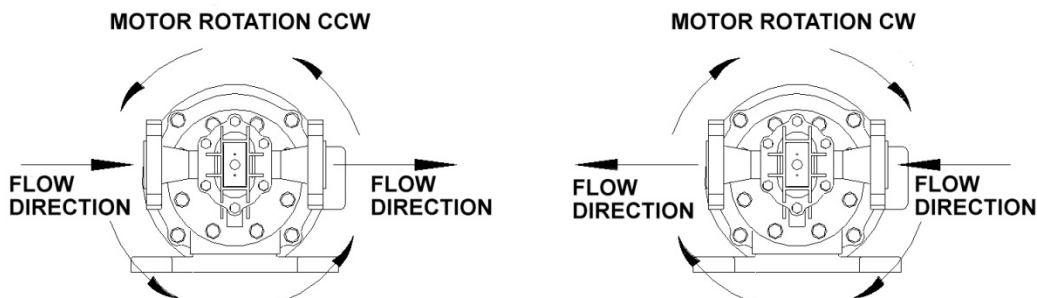



Figure 2b – Flow vs. Motor Rotation

5. Equipment Setup and Operation

- ✓ **Check Hardware Torque** - Hardware and fasteners can loosen during transportation and installation. All pump hardware should be torqued according to the table in **Section 29.2** before operation. Pump hardware should also be checked on a regular basis, especially if the pump is subject to temperature variations or cycling that might cause it to loosen during operation.

 **NOTE** All internal rotating components are wetted, lubricated, and cooled by the process fluid. All pumps should be fully wetted and primed prior to regular operation. It is not recommended that any magnetically driven pump be run dry. This condition can cause significant temperature increases resulting in premature damage to the gears and liner from lack of lubrication and/or vaporization of liquid in the pump.

- ✓ **Confirm Flow Direction** - As noted in **Section 4.2**, Eclipse Series pumps are bi-directional; the direction of flow is determined by the direction of motor rotation. Refer to Figure 2b.
- ✓ **Adjust PRV** - As a safety precaution, a pressure relief valve by-pass system is highly recommended (see **Section 4.1.1**). Ideally, the pressure relief valve is set for a low pressure at start-up to allow the pump to flood with liquid and evacuate air quickly. It can then be re-adjusted to a setting appropriate to the application.
- ✓ **Open Valves** - Prior to operation, make sure all suction piping is air tight and clean of debris. Start pump with discharge and suction valves open and check for proper operation. Excessive noise or vibration is an indication of harmful cavitation, which may be due to insufficient NPSH (Net Positive Suction Head).

 **NOTE** Do not operate the pump against a closed or blocked discharge. Operation against closed or blocked discharge can also result in excessive and unsafe casing pressure. This can also cause the magnetic drive to decouple. This can result in damage to the casing parts and/or containment can. If decoupling occurs, stop the motor and restart after the obstruction has been cleared.

 **WARNING** ALL MAGNETIC DRIVE COUPLINGS HAVE A SPECIFIC MAXIMUM TORQUE LIMIT. IF THIS TORQUE IS EXCEEDED THE DRIVE WILL DECOUPLE. OPERATION IN THE DECOUPLED MODE SHOULD BE AVOIDED AS HIGH TEMPERATURES COULD BE GENERATED.

- ✓ **Performance** – Review the performance curves in **Section 31** to reference the expected flow, pressure, and power characteristics for each Eclipse Series pump. Verify that these predicted working conditions correspond to the application. For information and safety precautions specific to a motor speed controller or any other accessories, please refer to the appropriate IOM.

 **NOTE** Eclipse Metallic 75/125 Power frames are shipped without oil. Use Standard motor oil: SAE 10W-30, 10W-40, or 5W-30.

6. Maintenance Overview

Accurate records from the early stages of pump operation will indicate the type and levels of required maintenance. Regular inspections and detailed maintenance records of past performance can be invaluable for determining future preventative maintenance intervals. For motor maintenance instructions consult the motor manufacturer.

Where pumped fluids may solidify, crystallize, or precipitate, provisions should be made to thoroughly flush pump and piping prior to periods of shutdown. Pay particular attention to proper flushing and draining of the magnetic coupling area because this area may not completely self-drain.



WARNING

BEFORE PERFORMING ANY MAINTENANCE REQUIRING PUMP DISASSEMBLY, BE SURE TO FLUSH AND DRAIN PUMP THOROUGHLY WITH A NEUTRALIZING FLUID. WEAR PROTECTIVE CLOTHING AND HANDLE EQUIPMENT WITH PROPER CARE.

DISCONNECT THE POWER SOURCE TO THE MOTOR BEFORE PERFORMING ANY MAINTENANCE.

Whenever gear pumps exhibit reduced flow rates, inability to maintain pressures, noisy or otherwise abnormal operation, first refer **Section 28 Troubleshooting** to determine potential causes and remedies. If the problem cannot be resolved, inspect the pump for wear or damage. Eclipse Series gear pumps can be easily opened for cleaning and inspection without disturbing piping connections by removing the pump front cover. Quite often, original hydraulic performance can be restored by simply changing the KOPkit, as described in **Section 6.1**.



NOTE

In the event of an unexpected pump stoppage, first ensure the environment is safe to approach the pump and system, following all local procedures and precautions and refer to Section 28 Troubleshooting. Follow appropriate power disconnect and Lockout/Tagout procedures.

6.1 Recommended Spares - KOPkits

All Eclipse gear pumps are designed for easy access to the regularly serviced internal components. These components are part of the Keep on Pumping kit, or KOPkit. The KOPkit provides an easy means to keep the right parts for your Eclipse Series pump close at hand. The basic Eclipse Series KOPkit consists of the following parts, which are recommended as typical spare parts.

- Drive Gear & Shaft Assembly 1 each
- Idler Gear and Shaft Assembly 1 each
- Housing Liner 1 each
- Bearings 2 each
- O-rings 1 – 2 each

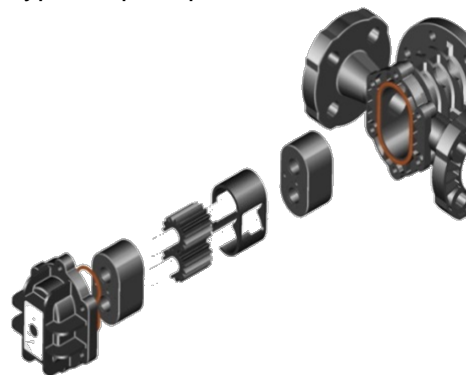

Figure 3 – KOPkit Components

KOPkit Identification

The model number stamped on the pump nameplate identifies the pump type and other details.

Refer to the model number chart in Section 10 for non-metallic pumps and Section 20 for metallic if you are unsure of exactly what type of pump you have, or when ordering parts or KOPkits.

Always refer to the full model and serial number in any correspondence with your Pulsafeeder representative. Drawings and consolidated bill of materials for each size pump are included in this manual. Recommended spare parts are identified on the consolidated bill of materials.

The KOPkit for an Eclipse pump can be installed without removing the pump from service. The pump can be disassembled while still connected to the process lines. Take precautions to ensure the pump is safe to work on.

Refer to **Section 27 Inspection and Wear Limits** for internal pump component description of wear and dimensional limits.

6.2 Maintenance Precautions for Magnet-driven Equipment:

- Non-magnetic tools and non-magnetic work surfaces are recommended to perform any disassembly or maintenance of the pump.
- Do not wear a wristwatch in the vicinity of the drive or driven magnets, wristwatches may be damaged by the transmission of magnetic flux.
- The strong magnetic field will damage credit cards, security badges, or other magnetic data strips. Keep them a safe distance from the magnets.



TAKE PRECAUTIONS IN HANDLING PUMP MAGNETS IF YOU HAVE PROSTHETIC DEVICES, METAL OR MEDICAL INSERTS, OR PACEMAKER INSTALLED IN YOUR BODY. CONSULT YOUR PHYSICIAN FOR GUIDANCE IN HANDLING MAGNETS.

- Completely flush and drain pump prior to pump disassembly.
- The exposed magnets on the drive magnet assembly are very fragile and will chip easily. Use extreme care in handling them.
- Take care to avoid magnetic particles or objects from attaching themselves to the drive magnets. It is difficult to remove small particles, and larger objects could be attracted with enough force to break the magnets.



Magnets (both drive and driven) can attract small particles of debris during handling. Always visually inspect the magnetic parts of the pump for cleanliness during re-assembly. Wipe carefully to remove debris, particles, or other small parts without damaging the surface of the magnets.



BE CAREFUL DURING DISASSEMBLY AND REASSEMBLY OF THE DRIVE AND DRIVEN MAGNET ASSEMBLIES. THE MAGNETIC ATTRACTION FORCES ARE HIGH, AND WHEN THE MAGNETS COME CLOSE TOGETHER THERE IS A STRONG TENDENCY TO SNAP TOGETHER SUDDENLY, POTENTIALLY CAUSING INJURY TO FINGERS OR FLESH.



DO NOT MACHINE THE MAGNETS OR MAGNET CARRIERS IN THE DRIVE OR DRIVEN MAGNET ASSEMBLIES. THE MAGNETIC DUST THAT WOULD BE PRODUCED IS HIGHLY FLAMMABLE.



The following sections of the IOM review disassembly and assembly of the Eclipse pump on a service bench. If you are working on your Eclipse pump in the field, the same procedures are used except that your pump will be horizontally mounted, whereas the illustrations in the IOM sections show the pumps in a vertical position.

ECLIPSE NON-METALLIC PUMPS

7. Disassembly/Assembly, Eclipse 02 Non-metallic

 **WARNING** BEFORE PERFORMING ANY MAINTENANCE REQUIRING PUMP DISASSEMBLY, BE SURE TO RELIEVE PRESSURE FROM THE PIPING SYSTEM, ISOLATE THE PUMP FULLY USING THE APPROPRIATE SHUTOFF/BLOCKING DEVICES, AND, WHERE HAZARDOUS PROCESS MATERIALS ARE INVOLVED, RENDER THE PUMP SAFE TO PERSONNEL AND THE ENVIRONMENT BY CLEANING AND CHEMICALLY NEUTRALIZING AS APPROPRIATE. WEAR PROTECTIVE CLOTHING AND EQUIPMENT AS REQUIRED.

7.1 Disassembly

- Close all suction and discharge valves.
 - Disconnect power source to motor. Follow local Lockout/Tagout procedures.
 - Flush and drain pump
 - Remove piping (optional for KOPkit).
 - The can area will not fully drain and will contain some process fluid.
 - Refer to the Parts Diagram and List in **Section 11**.
1. Remove the motor mounting hardware and slide the entire pump straight off the motor (optional for KOPkit).

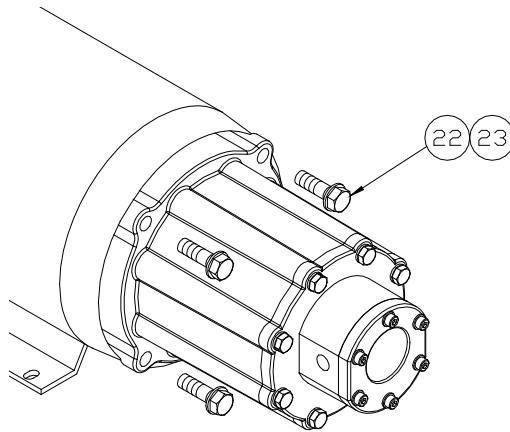

Figure 4 – Non-metallic

2. Place pump assembly (motor spool down) on the work surface.

3. Remove the front cover hardware and remove front cover as shown.

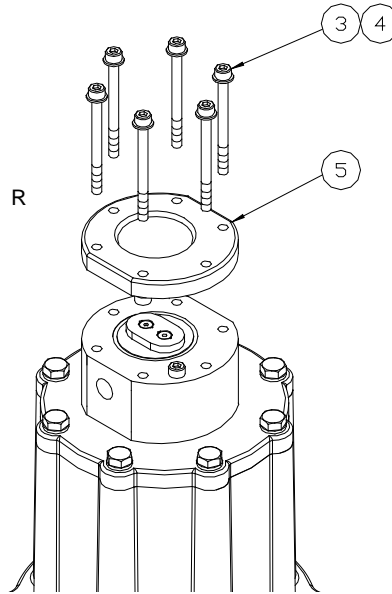

Figure 5 – Non-metallic

4. Remove bearings, gear/shaft assemblies, and housing liner as shown. These parts, along with the O-rings make up a standard Eclipse Series KOPkit. Check parts for wear and replace with a KOPkit as required.

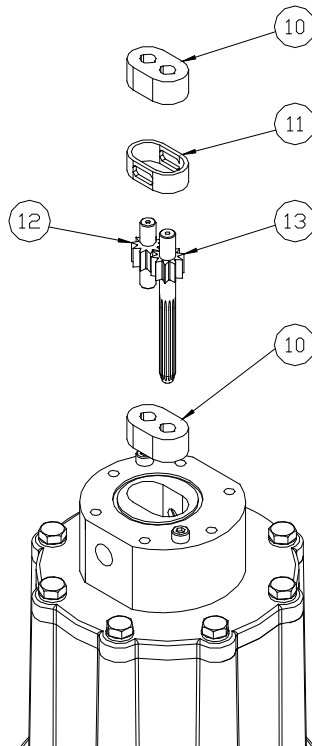

Figure 6 – Non-metallic

5. Remove the hardware to detach the center housing

- Remove all O-rings from the center housing and front cover. Non-metallic pumps have a total of three O-rings.

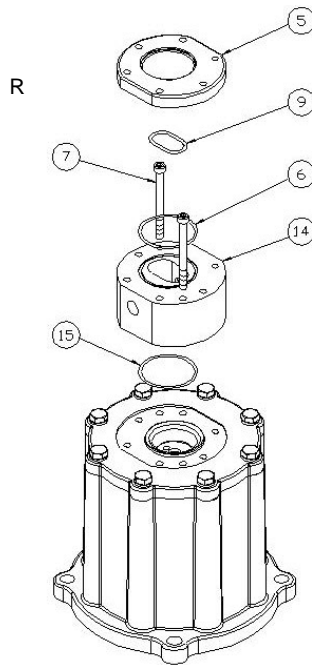

Figure 7 – Non-metallic

- Remove the mounting hardware holding the adapter plate to the motor spool and detach the adapter plate.
- Remove driven magnet assembly and containment can from adapter plate or spool as shown.

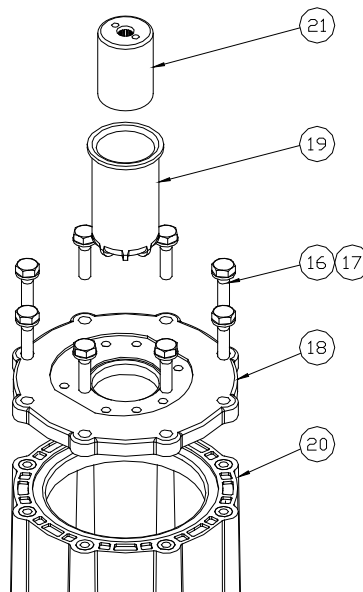

Figure 8 – Non-metallic



BE CAREFUL DURING DISASSEMBLY AND REASSEMBLY OF THE DRIVE AND DRIVEN MAGNET ASSEMBLIES. THE MAGNETIC ATTRACTION FORCES ARE HIGH, AND WHEN THE MAGNETS COME CLOSE TOGETHER THERE IS A STRONG TENDENCY TO SNAP TOGETHER SUDDENLY, POTENTIALLY CAUSING INJURY TO FINGERS OR FLESH.

9. Remove drive magnet assembly from the motor by loosening the setscrew in the magnet hub and slide off the motor shaft. Retain the key from the motor shaft.
10. If required for non-metallic pumps, the magnet hub (item 25) can be separated from the drive magnet (item 24) by removing the four screws (item 27).

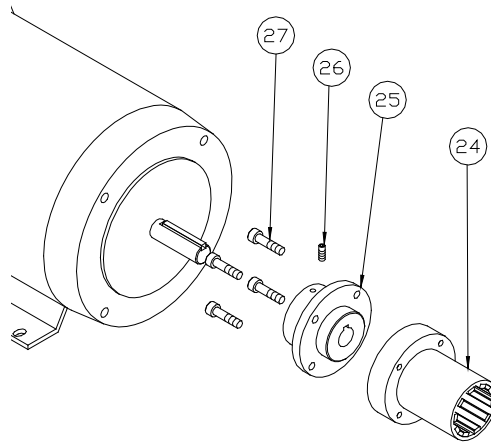

Figure 9 – Non-metallic

7.2 Assembly

1. Place motor spool flat on work surface. For non-metallic pumps, align “molded-in” flats on the spool adapter plate with any two of the motor mounting bolt holes on the motor spool as shown.
2. Set in place and install mounting bolts and washers. Tighten these bolts to the torque specified in **Section 29.2**. Always tighten fasteners in a progressive “crisscross” pattern.
3. Install the containment can into the spool or adapter plate until it is properly seated into the assembly.
4. Install the driven magnet assembly into the containment can. For non-metallic pumps the driven magnet is symmetrical and can be inserted with either end facing out (orientation does not matter).

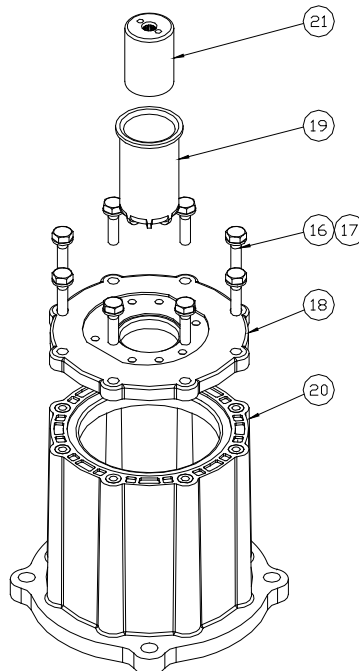

Figure 10 – Non-metallic

5. Inspect all O-rings to be sure there is no damage such as pinching prior to assembly.

6. Install O-rings into grooves on both sides of the center housing. Some O-ring lubricant may help keep the O-rings in place during assembly. Be sure both O-rings are fully seated into housing grooves.

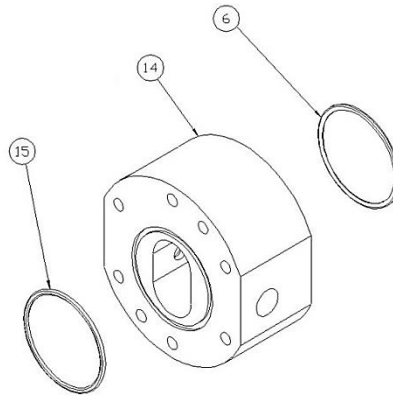

Figure 11 – Non-metallic

7. Place the center housing with O-rings installed onto the spool or adapter plate (open bore facing out), aligning the flat sides on the center housing to the flat sides on the spool adapter plate as shown on the non-metallic option. If the non-metallic center housing does not sit flat, rotate 180° until it seats into place.
8. Secure the center housing using two bolts in holes as shown in Figure 12. Tighten these bolts to the torque specified in **Section 29.2**. Always tighten fasteners in a progressive “crisscross” pattern.

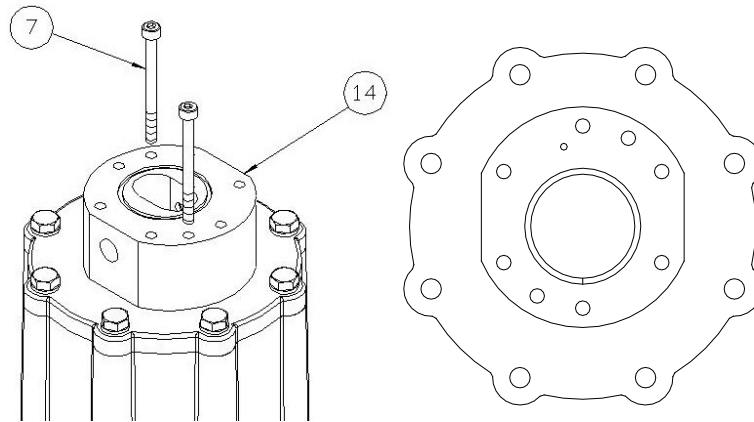

Figure 12 – Non-metallic

9. Insert a bearing into the center housing and slide to the bottom of the housing. Bearings are symmetrical and orientation does not matter.
10. Install the housing liner and slide until it seats against the first bearing. Install the idler gear into the top hole in bearing until the gear seats against the first bearing.
11. Install the drive gear, splined-end first, into the assembly until it bottoms out against the bearing. The shaft may have to be rotated slightly to properly fit the splined-end into the drive magnet and gear to the idler gear assembly.
12. Insert the second bearing into the housing bore until it rests against the housing liner. Bearings are symmetrical and orientation does not matter.

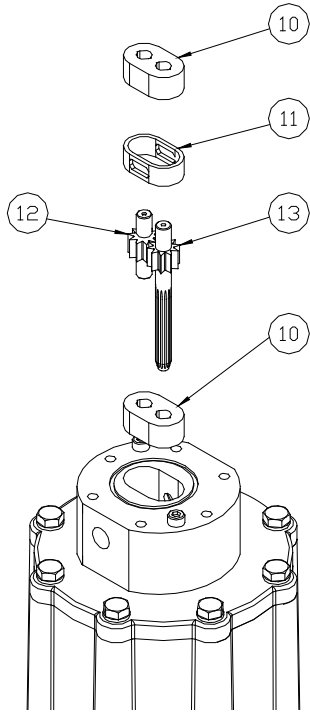

Figure 13 – Non-metallic

13. For non-metallic pumps, install the spacer O-ring into front cover as shown. Some o-ring lubricant may help keep the O-rings in place during assembly

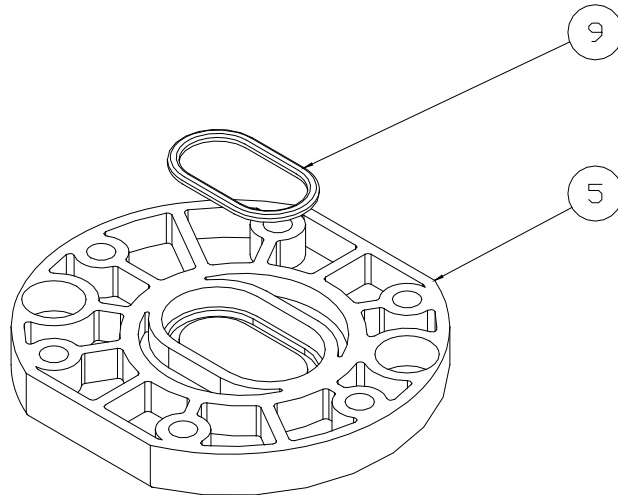

Figure 14 – Non-metallic

14. Install front cover. Tighten the bolts to the torque specified in **Section 29.2**. Always tighten fasteners in a progressive “crisscross” pattern.

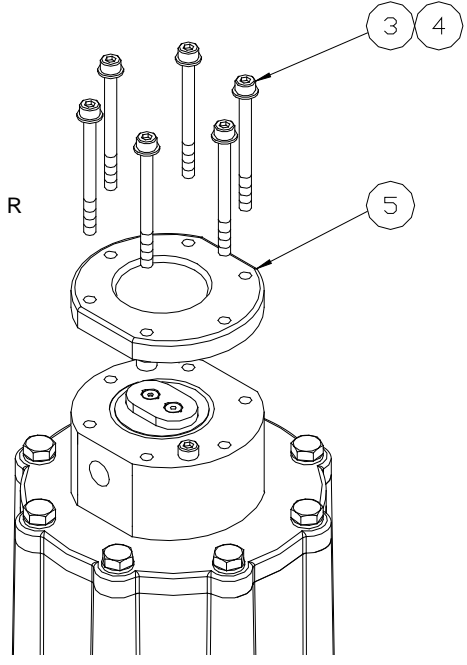

Figure 15 – Non-metallic

15. For non-metallic pumps with IEC frame motors, if the pump was removed from the motor, install the motor adaptor plate (item 31) onto the motor face using the four bolts and washers (items 29 and 30). Always tighten fasteners in a progressive “crisscross” pattern.

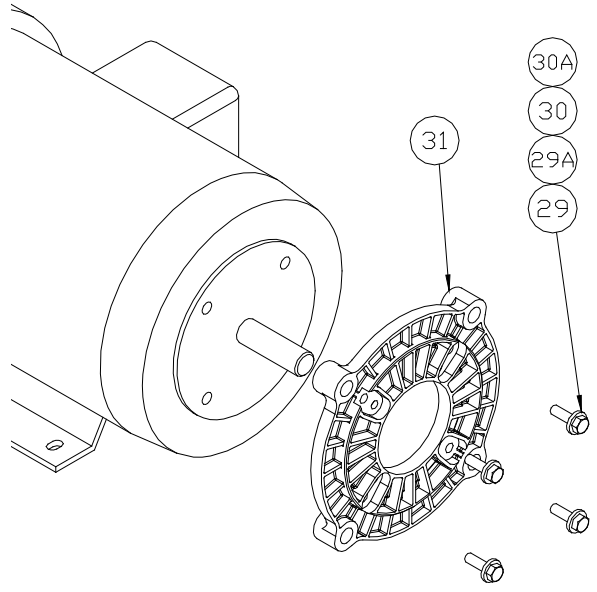

Figure 16 – Non-metallic

16. Secure the magnet hub (item 25) to the drive magnet (item 24) using the four screws (item 27) if disassembled on a non-metallic pump. Always tighten fasteners in a progressive “crisscross” pattern.

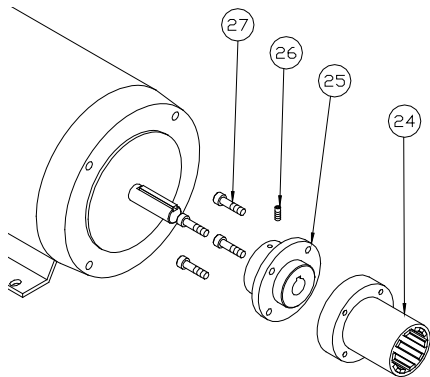

Figure 17 – Non-metallic

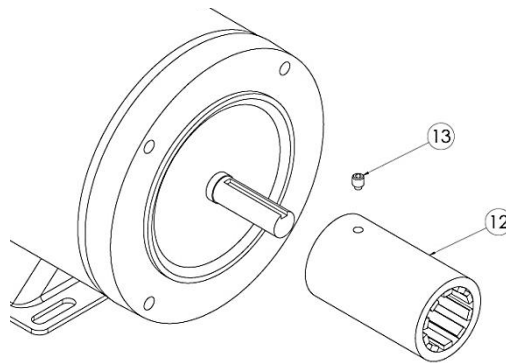

Figure 17 – Non-metallic



WARNING

BE CAREFUL DURING DISASSEMBLY AND REASSEMBLY OF THE DRIVE AND DRIVEN MAGNET ASSEMBLIES. THE MAGNETIC ATTRACTION FORCES ARE HIGH, AND WHEN THE MAGNETS COME CLOSE TOGETHER THERE IS A STRONG TENDENCY TO SNAP TOGETHER SUDDENLY, POTENTIALLY CAUSING INJURY TO FINGERS OR FLESH.

17. Align the keyway and slide the drive magnet onto the motor shaft until the end of the motor shaft is flush with face of the drive magnet motor or hub as shown in Figure 18. Secure with the setscrew. Application of a no-seize compound on the shaft and key will make future maintenance easier.

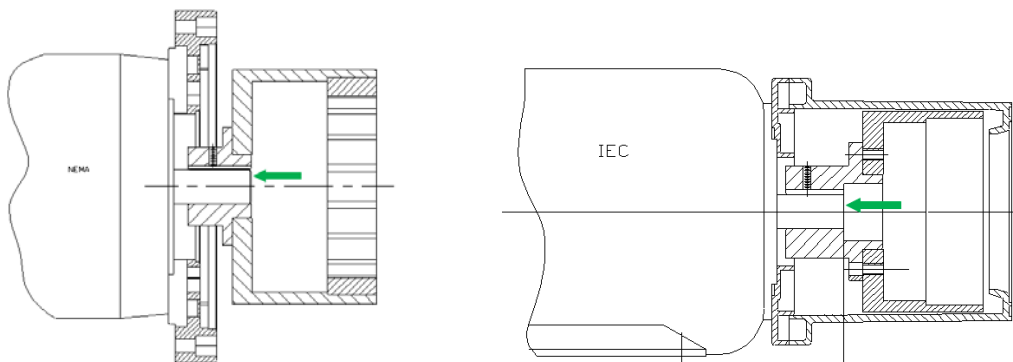

Figure 18

18. Complete assembly by replacing the assembled pump onto the motor, using care not to allow fingers to get pinched when the magnets attract. Secure the pump to the motor with the mounting hardware. Always tighten fasteners in a progressive “crisscross” pattern.

8. Disassembly/Assembly, Eclipse 05/12 and Eclipse 25 Non-metallic



BEFORE PERFORMING ANY MAINTENANCE REQUIRING PUMP DISASSEMBLY, BE SURE TO RELIEVE PRESSURE FROM THE PIPING SYSTEM, ISOLATE THE PUMP FULLY USING THE APPROPRIATE SHUTOFF/BLOCKING DEVICES, AND, WHERE HAZARDOUS PROCESS MATERIALS ARE INVOLVED, RENDER THE PUMP SAFE TO PERSONNEL AND THE ENVIRONMENT BY CLEANING AND CHEMICALLY NEUTRALIZING AS APPROPRIATE. WEAR PROTECTIVE CLOTHING AND EQUIPMENT AS REQUIRED.

8.1 Disassembly

- Close all suction and discharge valves.
 - Disconnect power source to motor. Follow local Lockout/Tagout procedures.
 - Flush and drain pump
 - Remove piping (optional for KOPkit).
 - The can area will not fully drain and will contain some process fluid.
 - Refer to the Parts Diagram and List in **Section 12, 13, and 14**.
1. Remove the motor mounting hardware and slide the entire pump straight off the motor (optional for KOPkit).

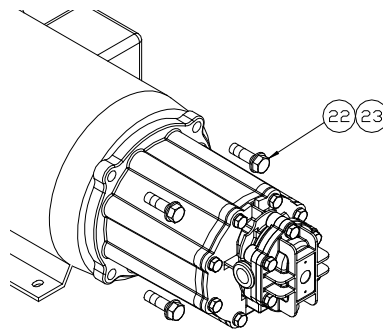

Figure 19 – Non-metallic E05/E12

2. Place pump assembly (motor spool down) on the work surface.
3. Remove all the front cover hardware and remove front cover as shown.

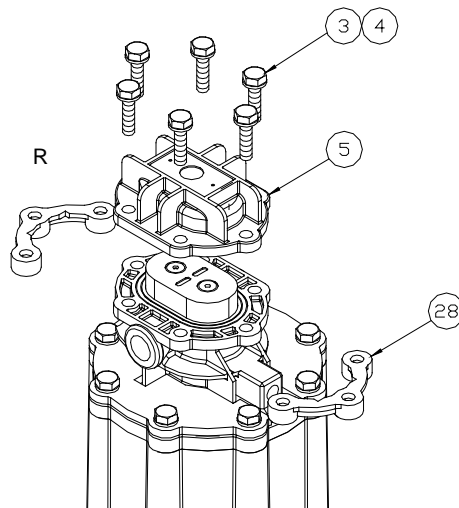

Figure 20 – Non-metallic

4. Remove bearings, gear/shaft assemblies, and housing liner as shown. These parts, along with the O-rings make up a standard Eclipse Series KOPkit. Check parts for wear and replace with a KOPkit as required.

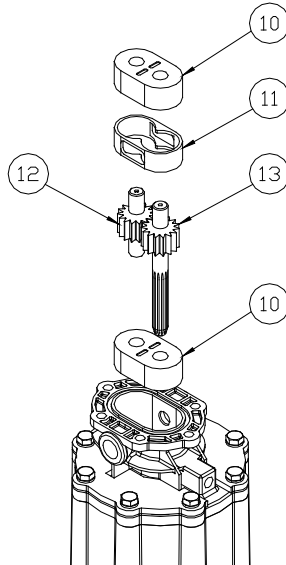

Figure 21 – Non-metallic

5. Remove the hardware holding the center housing to the motor spool. Remove the center housing and retaining plates for non-metallic pumps.
6. Remove all O-rings from the center housing and front cover. There are two O-rings in the center housing and one in the front cover as shown.

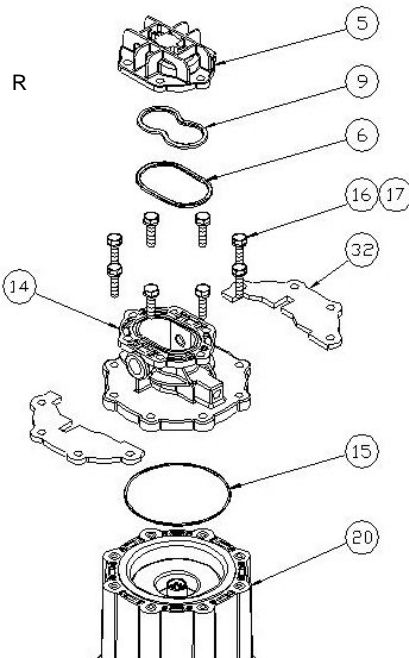

Figure 22 – Non-metallic

7. Remove driven magnet assembly and containment can from the motor spool.

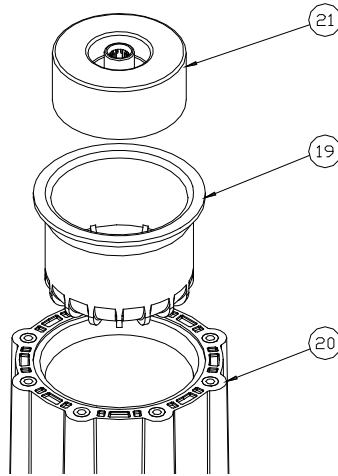

Figure 23 – Non-metallic



WARNING

BE CAREFUL DURING DISASSEMBLY AND REASSEMBLY OF THE DRIVE AND DRIVEN MAGNET ASSEMBLIES. THE MAGNETIC ATTRACTION FORCES ARE HIGH, AND WHEN THE MAGNETS COME CLOSE TOGETHER THERE IS A STRONG TENDENCY TO SNAP TOGETHER SUDDENLY, POTENTIALLY CAUSING INJURY TO FINGERS OR FLESH.

8. Remove drive magnet assembly from the motor by loosening the setscrew in the magnet hub and slide off the motor shaft. Retain the key from the motor shaft.
9. If required on non-metallic pumps, the magnet hub (item 25) can be separated from the drive magnet (item 24) by removing the four screws (item 27).
10. For E25 metallic pumps, the motor adaptor (item 14) must be removed first. Loosen the set screw in drive magnet assembly through the motor spool (item 19)

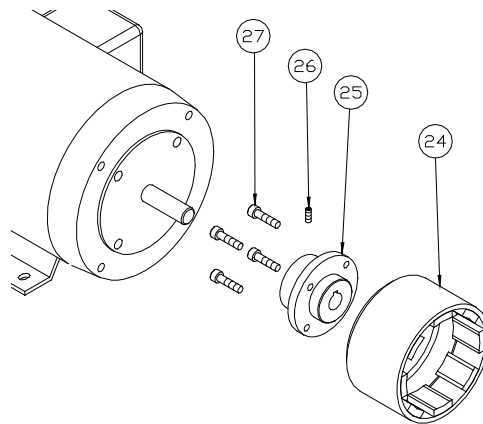

Figure 24 – Non-metallic E05/E12



WARNING

BE CAREFUL DURING DISASSEMBLY AND REASSEMBLY OF THE DRIVE AND DRIVEN MAGNET ASSEMBLIES. THE MAGNETIC ATTRACTION FORCES ARE HIGH, AND WHEN THE MAGNETS COME CLOSE TOGETHER THERE IS A STRONG TENDENCY TO SNAP TOGETHER SUDDENLY, POTENTIALLY CAUSING INJURY TO FINGERS OR FLESH.

8.2 Assembly

1. Place motor spool or adaptor flat on work surface.
2. Insert the containment can and driven magnet into the motor spool as shown. Non-metallic pump driven magnets are symmetrical and orientation does not matter.

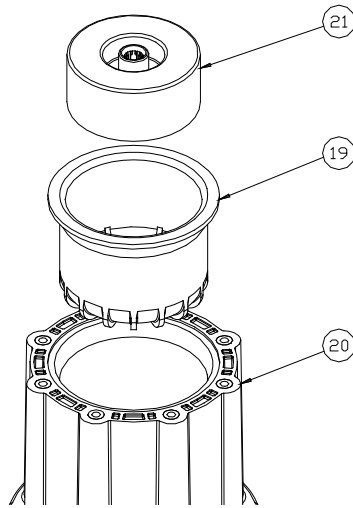

Figure 25 – Non-metallic

3. Inspect all O-rings to be sure there is no damage such as pinching prior to assembly.
4. Install O-rings into each side of the center housing as shown. Some O-ring lubricant may help keep the O-rings in place during assembly. Be sure both O-rings are fully seated into housing grooves.

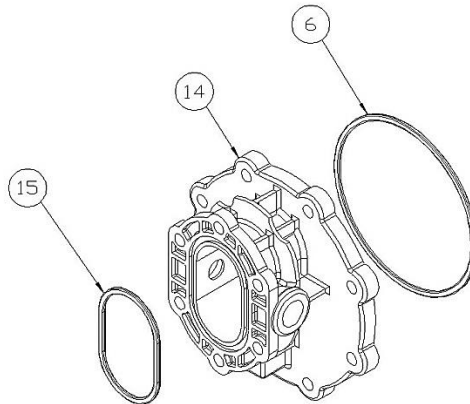

Figure 26 – Non-metallic

- Place the center housing, with O-rings, onto the motor spool or adaptor, aligning the port connections between any set of motor spool bolt holes as shown. Add the retaining plates for non-metallic pumps. Secure with the center housing hardware. Tighten these bolts to the torque specified in **Section 29.2**. Always tighten fasteners in a progressive “crisscross” pattern.

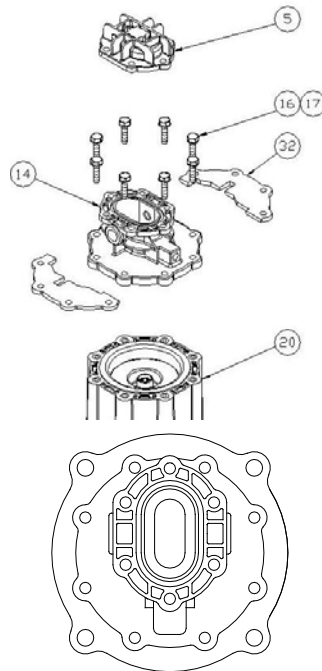

Figure 27 – Non-metallic

- Insert a bearing into center housing and slide to bottom of bore. Pump bearings are symmetrical and orientation does not matter. Install the housing liner and slide until it seats against the first bearing. Install idler gear into the top hole in bearing until the gear seats against the first bearing or wear plate.
- Install the drive gear, splined-end first, into the assembly until it bottoms out against the bearing or wear plate. The shaft may have to be rotated slightly to properly fit the splined-end into the drive magnet and mesh gear teeth with the idler gear.
- Insert the second bearing into the housing bore until it rests against the housing liner.

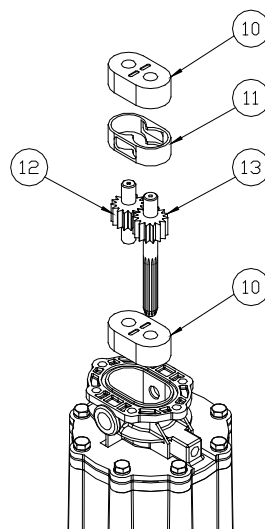

Figure 28 – Non-metallic

9. Install the spacer O-ring into the front cover as shown. Some O-ring lubricant may help keep the O-rings in place during assembly.

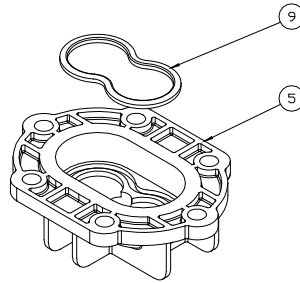

Figure 29 – Non-metallic

10. Place the front cover with O-ring onto the assembled pump. Secure with the front cover hardware. For non-metallic pumps, the flat side of the nut plates (item 28) mates against the back of the center housing flange. Tighten these bolts to the torque specified in **Section 29.2**. Always tighten fasteners in a progressive “crisscross” pattern.

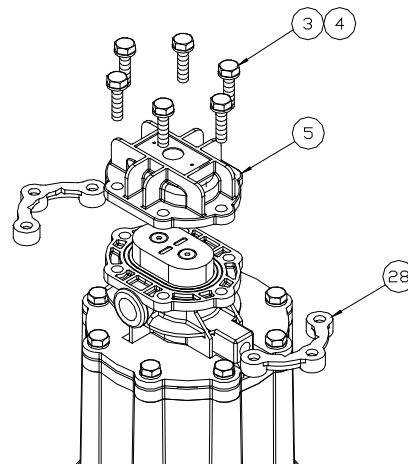

Figure 30 – Non-metallic

11. For non-metallic pumps with IEC frame motors, if the pump was removed from the motor, install the motor adaptor plate (item 31) onto the motor face using the four bolts and washers (items 29 and 30). Always tighten fasteners in a progressive “crisscross” pattern.

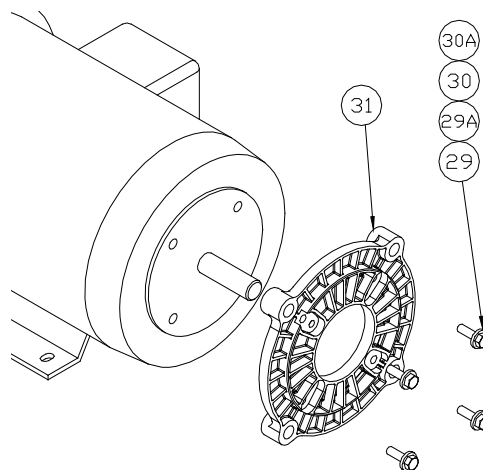

Figure 31 – Non-metallic

12. Secure the magnet hub (item 25) to the drive magnet (item 24) using the four screws (item 27) if disassembled on a non-metallic pump. Always tighten fasteners in a progressive “crisscross” pattern.

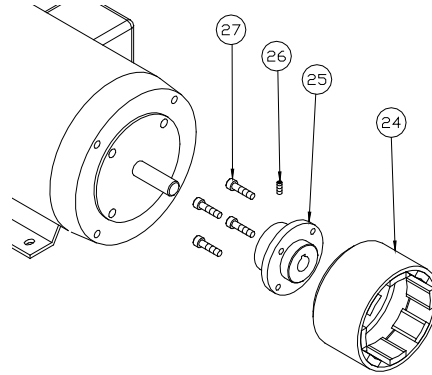

Figure 32 – Non-metallic



BE CAREFUL DURING DISASSEMBLY AND REASSEMBLY OF THE DRIVE AND DRIVEN MAGNET ASSEMBLIES. THE MAGNETIC ATTRACTION FORCES ARE HIGH, AND WHEN THE MAGNETS COME CLOSE TOGETHER THERE IS A STRONG TENDENCY TO SNAP TOGETHER SUDDENLY, POTENTIALLY CAUSING INJURY TO FINGERS OR FLESH.

13. Align the keyway, and slide the drive magnet onto the motor shaft until the end of the motor shaft aligns with faces of the drive magnet motor hub as shown below. Secure with the setscrew. Application of a no-seize compound on the shaft and key will make future maintenance easier.

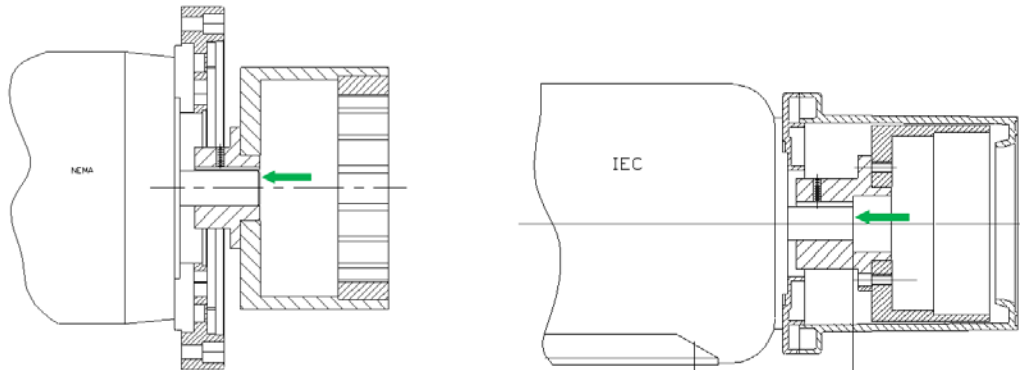

Figure 33

14. Complete assembly by replacing the assembled pump onto the motor, using care not to allow fingers to get pinched when the magnets attract. Secure the pump to the motor with the four bolts and washers. Always tighten fasteners in a progressive “crisscross” pattern.

9. Disassembly/Assembly, Eclipse 25/75/125 Non-Metallic



WARNING

BEFORE PERFORMING ANY MAINTENANCE REQUIRING PUMP DISASSEMBLY, BE SURE TO RELIEVE PRESSURE FROM THE PIPING SYSTEM, ISOLATE THE PUMP FULLY USING THE APPROPRIATE SHUTOFF/BLOCKING DEVICES, AND, WHERE HAZARDOUS PROCESS MATERIALS ARE INVOLVED, RENDER THE PUMP SAFE TO PERSONNEL AND THE ENVIRONMENT BY CLEANING AND CHEMICALLY NEUTRALIZING AS APPROPRIATE. WEAR PROTECTIVE CLOTHING AND EQUIPMENT AS REQUIRED.



NOTE

Eclipse Metallic 75/125 Power frames are shipped without oil. Use Standard motor oil: SAE 10W-30, 10W-40, or 5W-30.

9.1 Disassembly

- Close all suction and discharge valves.
- Disconnect power source to motor. Follow local Lockout/Tagout procedures.
- Flush and drain pump
- Remove piping (optional for KOPkit).
- The can area will not fully drain and will contain some process fluid
- Refer to the Parts Diagram and List in **Section 14, 15, and 16**.

1. Remove the motor mounting hardware and slide the entire pump straight off the motor (optional for KOPkit).

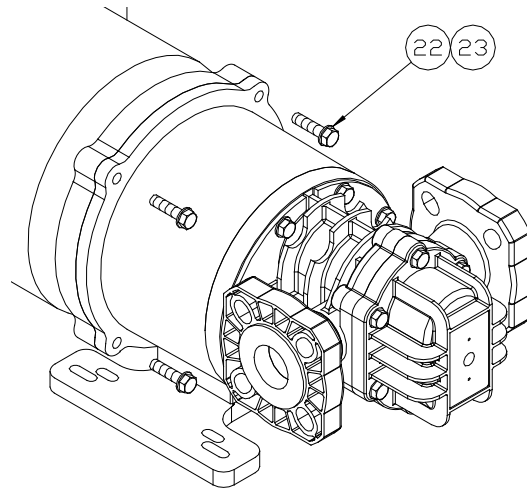

Figure 34 – Non-metallic

2. Place pump assembly (motor spool down) on the work surface.
3. Remove the front cover hardware and remove front cover as shown. If required for non-metallic pumps, the mounting base (item 32) can be detached by removing the four bolts and washers (items 33, 34) as shown.

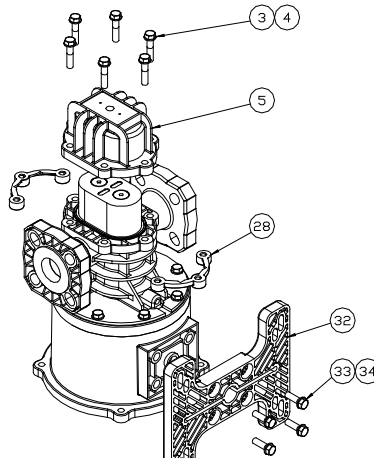

Figure 35 – Non-metallic

- Remove bearings, gear/shaft assemblies, and housing liner as shown. These parts, along with the O-rings make up a standard Eclipse Series KOPkit. Check parts for wear and replace with a KOPkit as required.

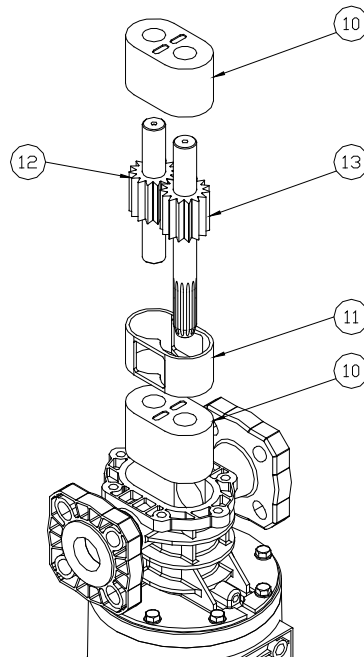

Figure 36 - Non-metallic

- Remove the hardware holding the center housing to the motor spool or power frame housing. Detach the center housing and retaining plates for non-metallic pumps.
- Remove all O-rings from the center housing and front cover. There is one o-ring in the center housing and two in the front cover as shown.

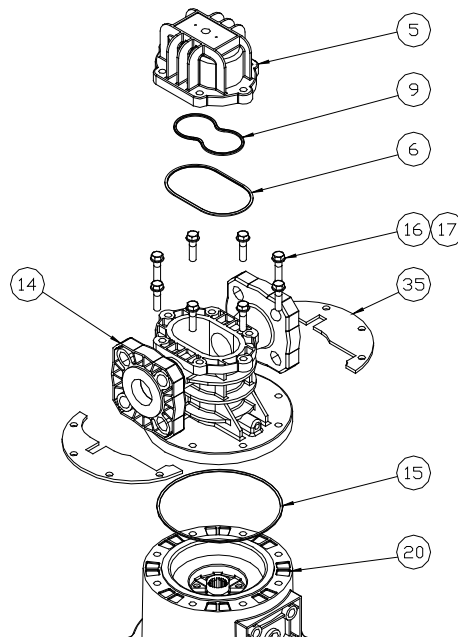

Figure 37 – Non-metallic

- For non-metallic pumps remove driven magnet assembly (item 21) and containment can (item 19) from the motor spool (item 20) as shown.

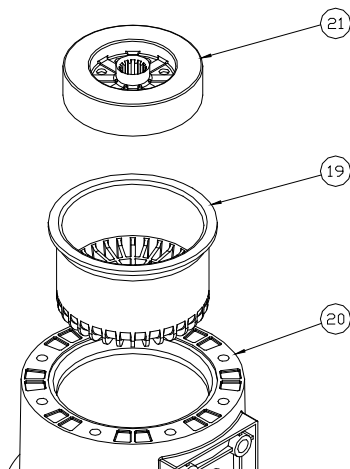

Figure 38 – Non-metallic

- For non-metallic pumps, remove drive magnet assembly from the motor by loosening the setscrew in the magnet hub and slide off the motor shaft. Retain the key from the motor shaft.
- The magnet hub can be separated from the drive magnet by removing the four screws and detaching.



WARNING

BE CAREFUL DURING DISASSEMBLY AND REASSEMBLY OF THE DRIVE AND DRIVEN MAGNET ASSEMBLIES. THE MAGNETIC ATTRACTION FORCES ARE HIGH, AND WHEN THE MAGNETS COME CLOSE TOGETHER THERE IS A STRONG TENDENCY TO SNAP TOGETHER SUDDENLY, POTENTIALLY CAUSING INJURY TO FINGERS OR FLESH.

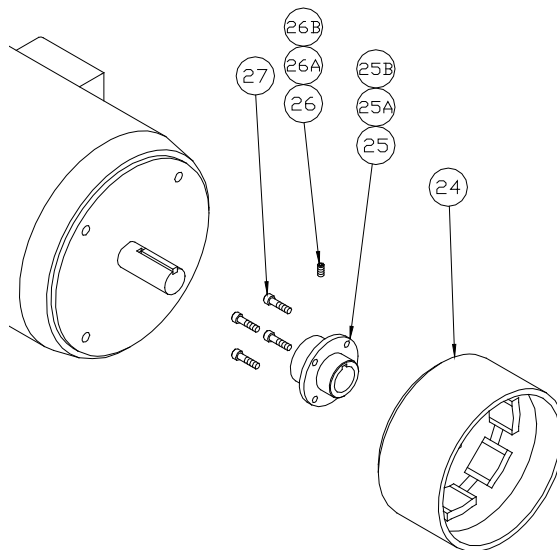

Figure 39 – Non-metallic

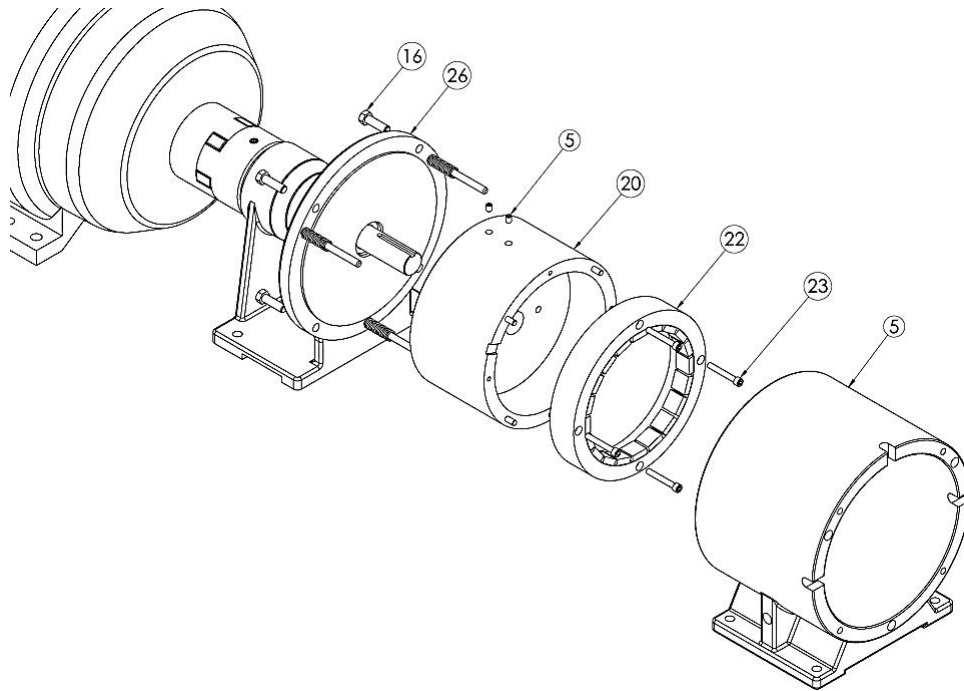

Figure 39 – Non-metallic

9.2 Assembly

1. Place motor spool or adaptor flat on work surface.
2. For non-metallic pumps, insert containment can (item 19) and driven magnet (item 21) into motor spool (item 20) as shown. The driven magnet is symmetrical and orientation does not matter.
3. Install o-ring (item 15) into the back side of the center housing (item 14) as shown. Some o-ring lubricant may help keep O-rings in place during assembly. Be sure the o-ring is fully seated into housing groove.

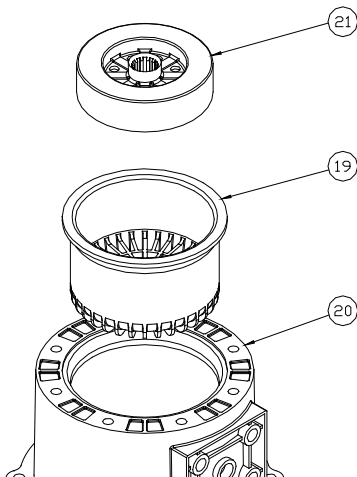

Figure 40 – Non-metallic

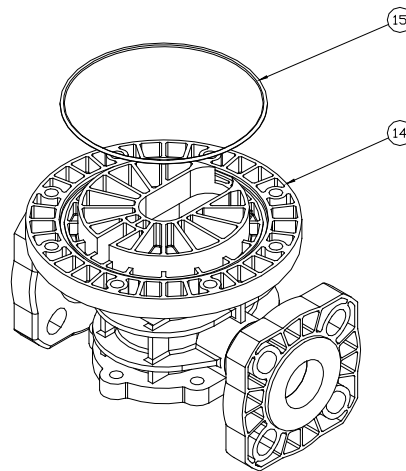

Figure 41 – Non-metallic

4. Install O-ring (item 11) into the back side of the center housing (item 1). Some O-ring lubricant may help keep O-rings in place during assembly.
5. Then install the can and magnet with the containment can ring (item 25) and bolts (item 24) onto the center housing.



Inspect all O-rings to be sure there is no damage such as pinching prior to assembly.

- Place the center housing onto the motor spool or adaptor, aligning the port connections with the pump baseplate as shown. Add the two retaining plates for non-metallic pumps. Secure with center housing hardware. Tighten bolts to the torque specified in **Section 29.2**. Always tighten fasteners in a progressive “crisscross” pattern.

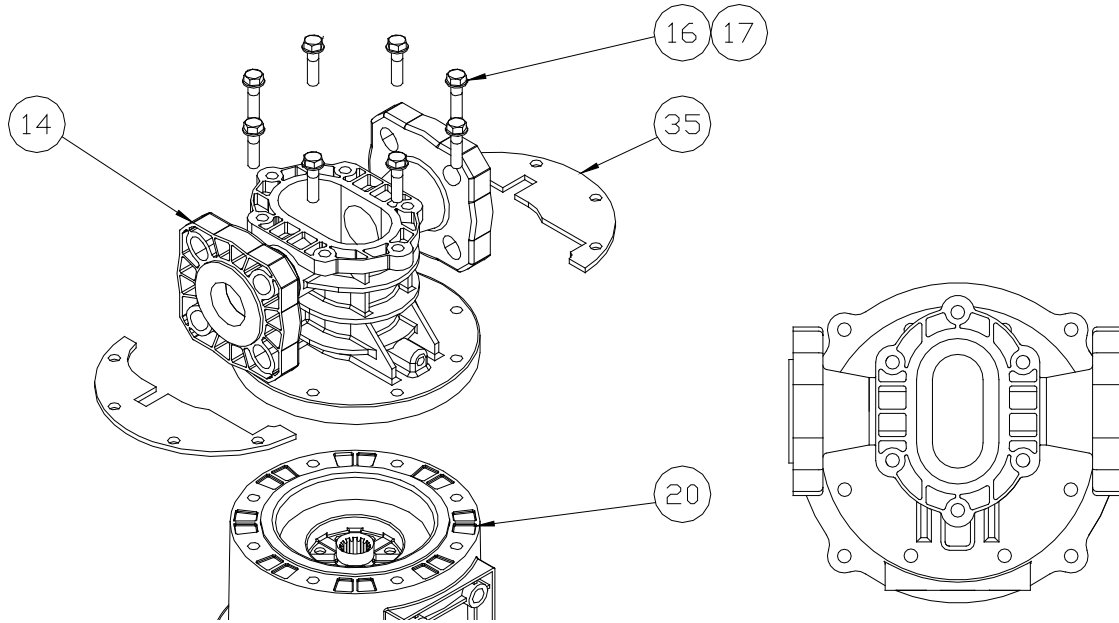

Figure 42 – Non-metallic

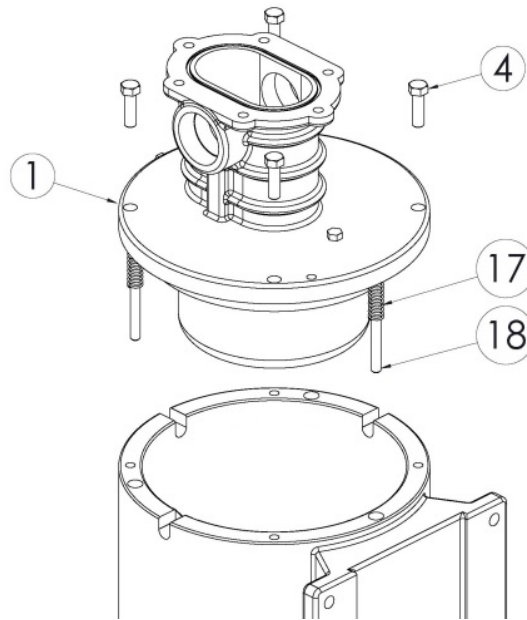

Figure 42 – Non-metallic

- Insert a bearing into center housing and slide to bottom of bore. Bearings are symmetrical and orientation does not matter. Install the housing liner and slide until it seats against the first bearing. Install idler gear into the top hole in the bearing until the gear seats against the first bearing.
- Install the drive gear splined-end first into the assembly until it bottoms out against the bearing. The shaft may have to be rotated slightly to properly fit the splined-end into the drive magnet and mesh gear teeth with the idler gear.

9. Insert the second bearing into the housing bore until it rests against the housing liner. Bearings are symmetrical and orientation does not matter.

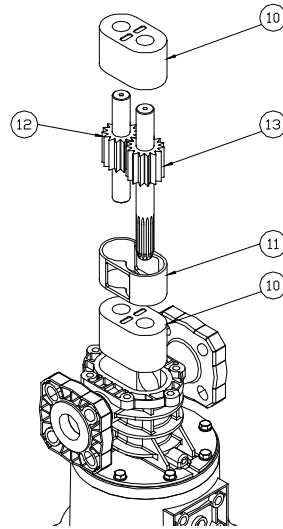

Figure 43 – Non-metallic

10. Install the two O-rings into the front cover as shown. Some O-ring lubricant may help keep the O-rings in place during assembly.

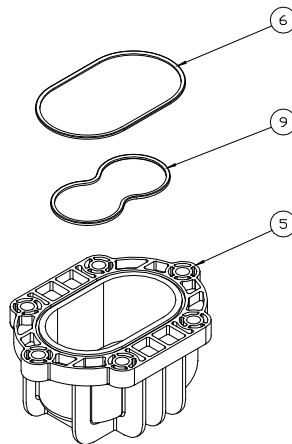

Figure 44 – Non-metallic

11. Place the front cover with O-ring onto the assembled pump. Secure with the front cover hardware. For non-metallic pumps, flat side of the nut plates (item 28) mates against the back of the center housing flange. Tighten bolts to the torque specified in **Section 29.2**. Always tighten fasteners in a progressive “crisscross” pattern.

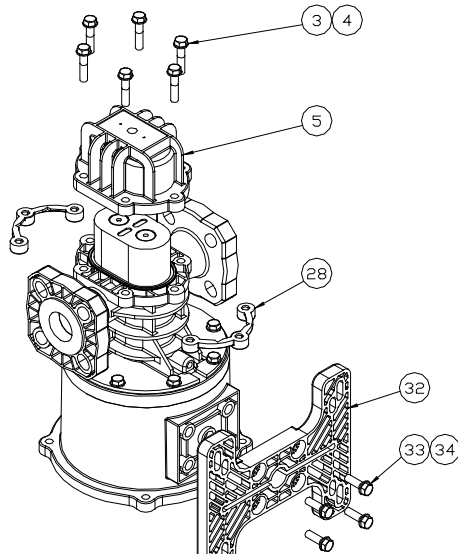

Figure 44 – Non-metallic

12. If removed from non-metallic pumps, secure the mounting base (item 32) to the motor spool (item 20) using the four bolts and washers (items 33, 34) as shown. Always tighten fasteners in a progressive “crisscross” pattern.
13. If removed from non-metallic pumps, install the motor adaptor plate (item 18) onto the motor face using the four bolts and washers (items 29 and 30). Always tighten fasteners in a progressive “crisscross” pattern.

NOTE: E125 May use (2) Adaptor Plates, ref #18.

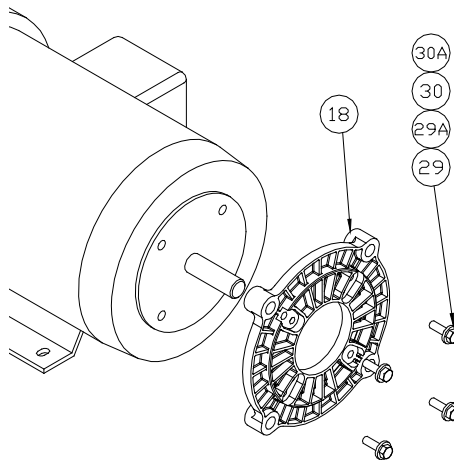

Figure 45 – Non-metallic

14. Secure the magnet hub to the drive magnet using the four screws. Always tighten fasteners in a progressive “crisscross” pattern.

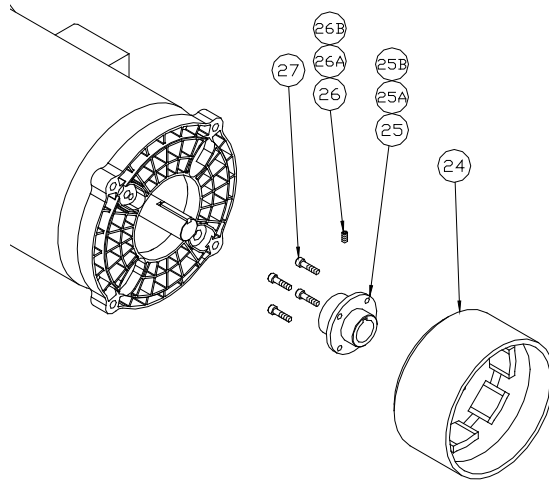

Figure 46 – Non-metallic



WARNING

Be careful during disassembly and reassembly of the drive and driven magnet assemblies. The magnetic attraction forces are high; and, when the magnets come close together, there is a strong tendency to snap together suddenly, potentially causing injury to fingers or flesh.



NOTE

Eclipse Metallic 75/125 Power frames are shipped without oil. Use Standard motor oil: SAE 10W-30, 10W-40, or 5W-30.

15. Align the keyway, and slide the drive magnet onto the motor shaft until the end of the motor shaft aligns with faces of the drive magnet motor hub as shown below. Secure with the setscrew. Application of a no-seize compound on the shaft and key will make future maintenance easier.
16. Complete assembly by replacing the assembled pump onto the motor or power frame, using care not to allow fingers to get pinched when the magnets attract. Secure the pump with the appropriate hardware. Always tighten fasteners in a progressive “crisscross” pattern.

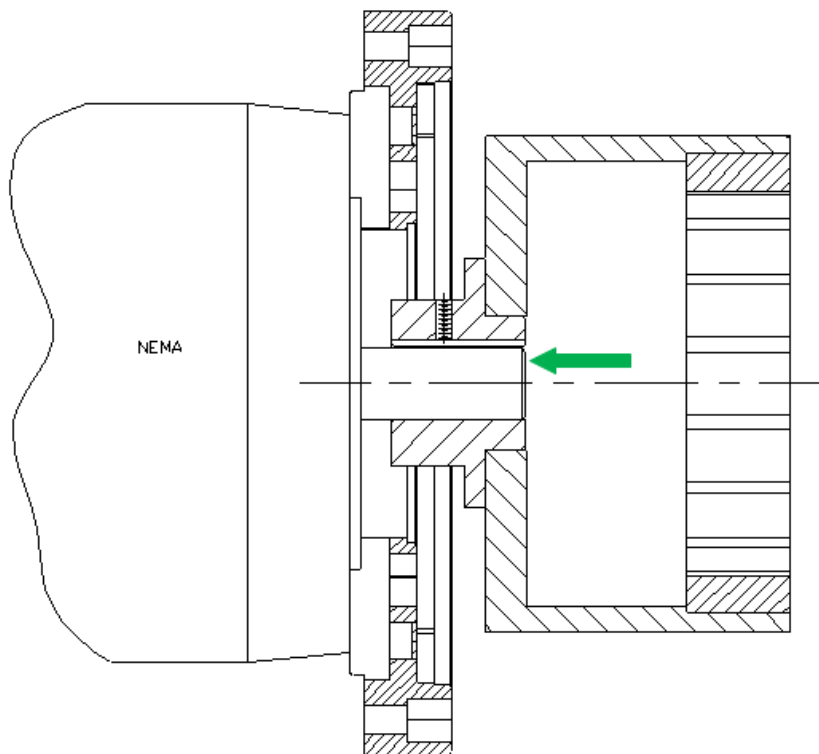

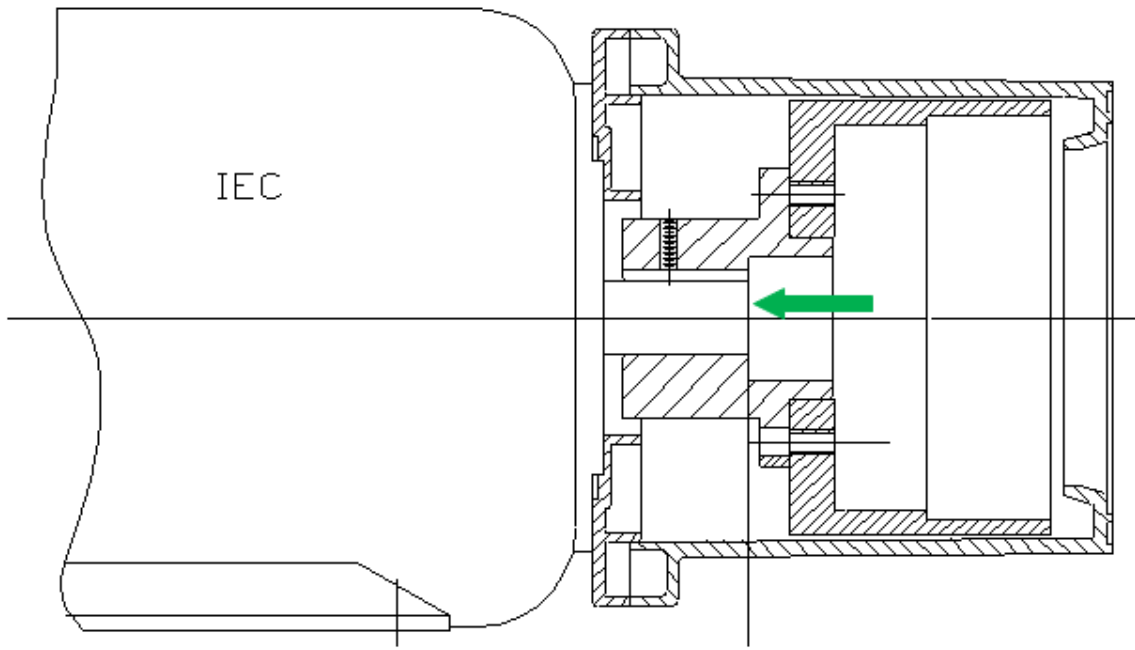

Figure 47

10. Pump Model Identification – Non-Metallic

Position	Code	Specifies	Options	Available Pump Size
1	E	Model	E – Eclipse	All – Non-metallic
2 and 3	02, 05, 12, 25, 75, 125	Pump Size	02 – Max. Capacity .4 gpm (1.5 lpm) 05 – Max. Capacity 1.7 gpm (6.3 lpm) 12 – Max. Capacity 3.4 gpm (12.9 lpm) 25 – Max. Capacity 7.4 gpm (28.0 lpm) 75 – Max Capacity 22 gpm (83.3 lpm) 125 – Max Capacity 33 gpm (125 lpm)	
4	K, M, N,	Base Material	K – PVDF, FNPT M – PVDF, BSPT N – PVDF, FLANGED	02, 05, 12* 02, 05, 12* 25*, 75*, 125*
5	L, B	Bearings	L – Carbon-92 B – Silicon Carbide	All All
6	V, E, K, U	O-rings	V – Viton A E – EPDM K – Kalrez Grade 4079	All All All
7	F, O, H, J K, L, P, R, W, Y	Motor Mounting	F – NEMA 56C O – NEMA 143/5TC-182/4C H – IEC 63 B3/B14 J – IEC 71 B3/B14 K – IEC 80 B3/B14 L – IEC 90 B3/B14 P – IEC 100/112 B3/B14 R – NEMA 182-184TC W – NEMA 213TC – 215TC Y – Less Mounting Kit (includes drive magnet)***	02, 05, 12, 25, 75 All 02, 05, 12 02, 05, 12 02, 05, 12, 25, 75 25, 75 25, 75, 125 75, 125 75, 125 All
8	-		Dash	All
9	X, N	Options	X – Ceramic shafts and Teflon gears A – Bearing Flush Port N – Wet end only (use when Position 7 = Y)*** B – Combination of 9 th position options “A” & “N” X-ATEX – Option X with ATEX Directive** A-ATEX – Option A with ATEX Directive** N-ATEX – Option N with ATEX Directive** B-ATEX – Option B with ATEX Directive**	All All All All All All All All

***Export restrictions apply to these sizes in these material choices.**

ATEX Directive - CE Ex II 2G T6 II 2D T6, refer to **Section 3

***Complete pump model number with Position 7, Code “Y” includes the drive magnet, less motor mounting kit. Option code “N” is only available in conjunction with Position 7, Code “Y”, which excludes the drive magnet.

10.1 KOPkit Part Number Identification – Non-Metallic

Position	Code	Specifies	Options
1	E	Model	E – Eclipse
2 and 3	02, 05, 12, 25, 75, 125	Pump Size	02 – Max. Capacity .4 gpm (1.5 lpm) 05 – Max. Capacity 1.3 gpm (4.9 lpm) 12 – Max. Capacity 3.2 gpm(12.1 lpm) 25 – Max. Capacity 6.5 gpm (24.6 lpm) 75 – Max Capacity 20 gpm (75 lpm) 125 – Max Capacity 33 gpm (125 lpm)
4	X	Base Material	X – All base material types
5	L, B	Bearings	L – Carbon-92 B – Silicon Carbide
6	V, E, K, U	O-rings	V – Viton A E – EPDM K – Kalrez Grade 4079
Suffix	-LTE, -STD -PRO	Kit Selection*	-LTE Liners, Gears, Cover O-ring -STD Liners, Gears, Bearings, O-rings -PRO Liners, Gears, Bearings, O-rings, Hardware

*Kits always contain ceramic shafts and Teflon gears

11. Parts Diagram and List, Eclipse 02 Non-Metallic

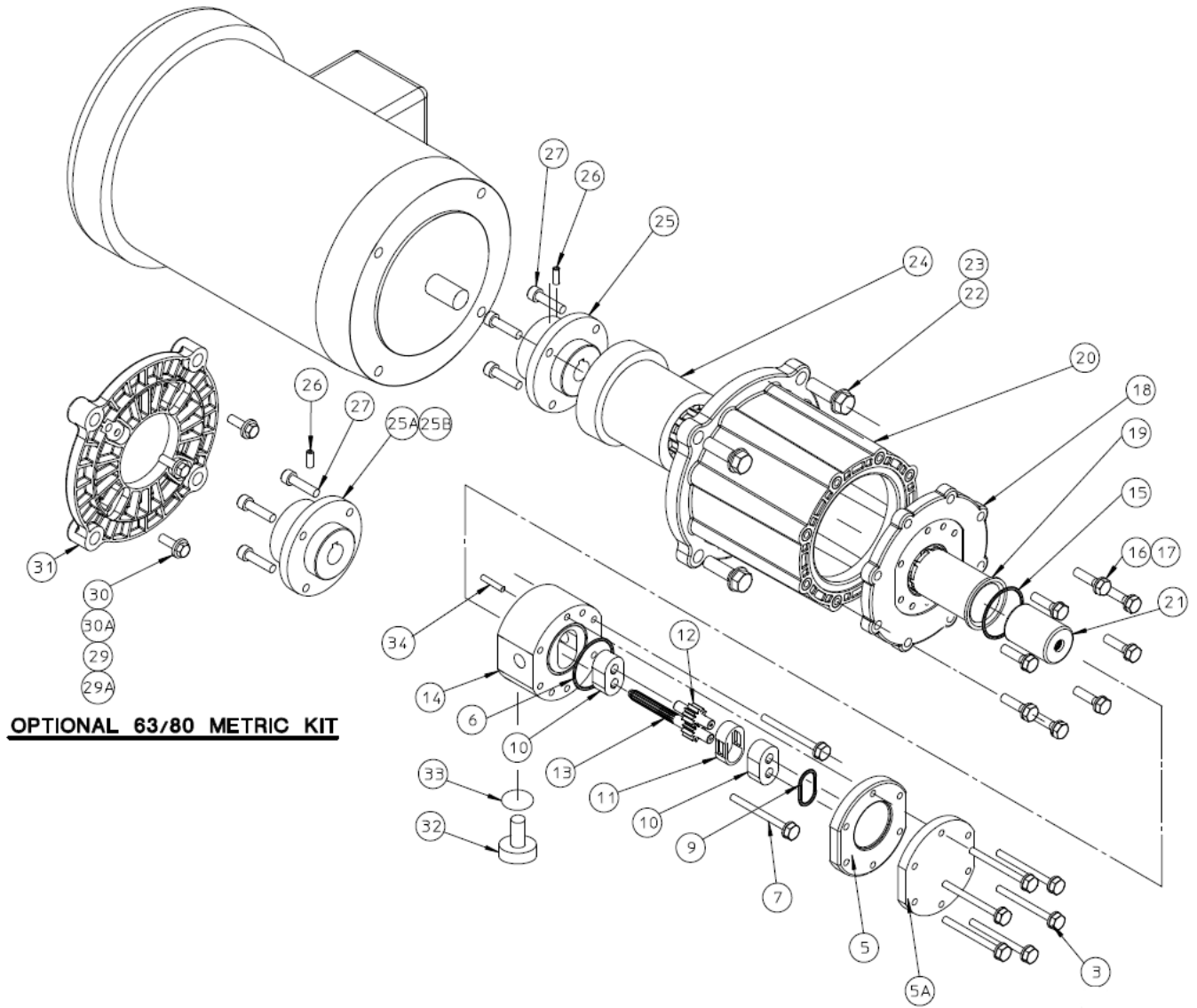

Eclipse Pump Series Size 02 Non-Metallic Parts Diagram Key

Position 1, 2, 3, 4 – Base Pump Material/Ports

Item	Description	Quantity
N/S	Name Plate	1
3	Screw	6
5	Cover, Front	1
5A	Plate, Cover Reinforcement	1
7	Screw	2
14	Housing, Center FNPT	1
	Housing, Center FBSPT	1
16	Bolt	8
17	Washer	8
18	Adapter, Can	1
19	Can, Containment	1
20	Adapter, Spool	1
21	Driven Magnet Assembly	1
24	Drive Magnet	1
32	Plug, Drain	1
34	Roll Pin	1

Position 5 – Bearing Materials

Item	Description	Quantity
10	Bearing	2
	Bearing	2
11	Liner, Housing	1
12	Gear Assembly, Idler	1
13	Gear Assembly, Drive	1

Position 6 – O-Ring Material Selection

Item	Description	Quantity
6	O-ring Cover	1
9	O-ring Compression	1
15	O-ring Containment Can	1
33	O-ring Drain Plug	1

Position 7 - NEMA C-Face and IEC B34 Metric Frame Magnetic Coupling Arrangement

56C NEMA frame components

Item	Description	Quantity
22	Bolt	4
23	Washer	4
25	Coupling Hub	1
26	Set Screw	1
27	Screw	4
Motor Mount Kit #	E02XXXF	

143TC-182C NEMA frame components

Item	Description	Quantity
22	Bolt	4
23	Washer	4
25	Coupling Hub	1
26	Set Screw	1
27	Screw	4
Motor Mount Kit #	E02XXXO	

63 IEC B34 frame components

Item	Description	Quantity
22	Bolt	4
23	Washer	4
25A	Coupling Hub	1
26A	Set Screw	1
27	Screw	4
29	Bolt	4
30	Washer	4
31	Adapter, Motor	1
Motor Mount Kit #	E02XXXH	

71 IEC B34 frame components

Item	Description	Quantity
22	Bolt	4
23	Washer	4
25A	Coupling Hub	1
26A	Set Screw	1
27	Screw	4
29	Bolt	4
30	Adapter, Motor	1
Motor Mount Kit #	E02XXXJ	

80 IEC B34 frame components

Item	Description	Quantity
22	Bolt	4
23	Washer	4
27	Screw	4
25B	Coupling Hub	1
26B	Set Screw	1
29A	Bolt	4
30A	Washer	4
31	Adapter, Motor	1
Motor Mount Kit #	E02XXXXK	

KOPKit Suffix Selection Bill of Materials

Item	Description – LTE	Quantity
6	O-ring Cover	1
11	Liner, Housing	1
12	Gear Assembly, Liner	1
13	Gear Assembly Drive	1

Item	Description – STD	Quantity
6	O-ring Cover	1
9	O-ring Compression	2
10	Bearing	2
11	Liner, Housing	1
12	Gear Assembly, Liner	1
13	Gear Assembly, Drive	1

Item	Description - PRO	Quantity
6	O-ring Cover	1
9	O-ring Compression	2
10	Bearing	2
11	Liner, Housing	1
12	Gear Assembly, Liner	1
13	Gear Assembly, Drive	1
6	Bolt	6

12. Parts Diagram and List, Eclipse 05 Non-metallic

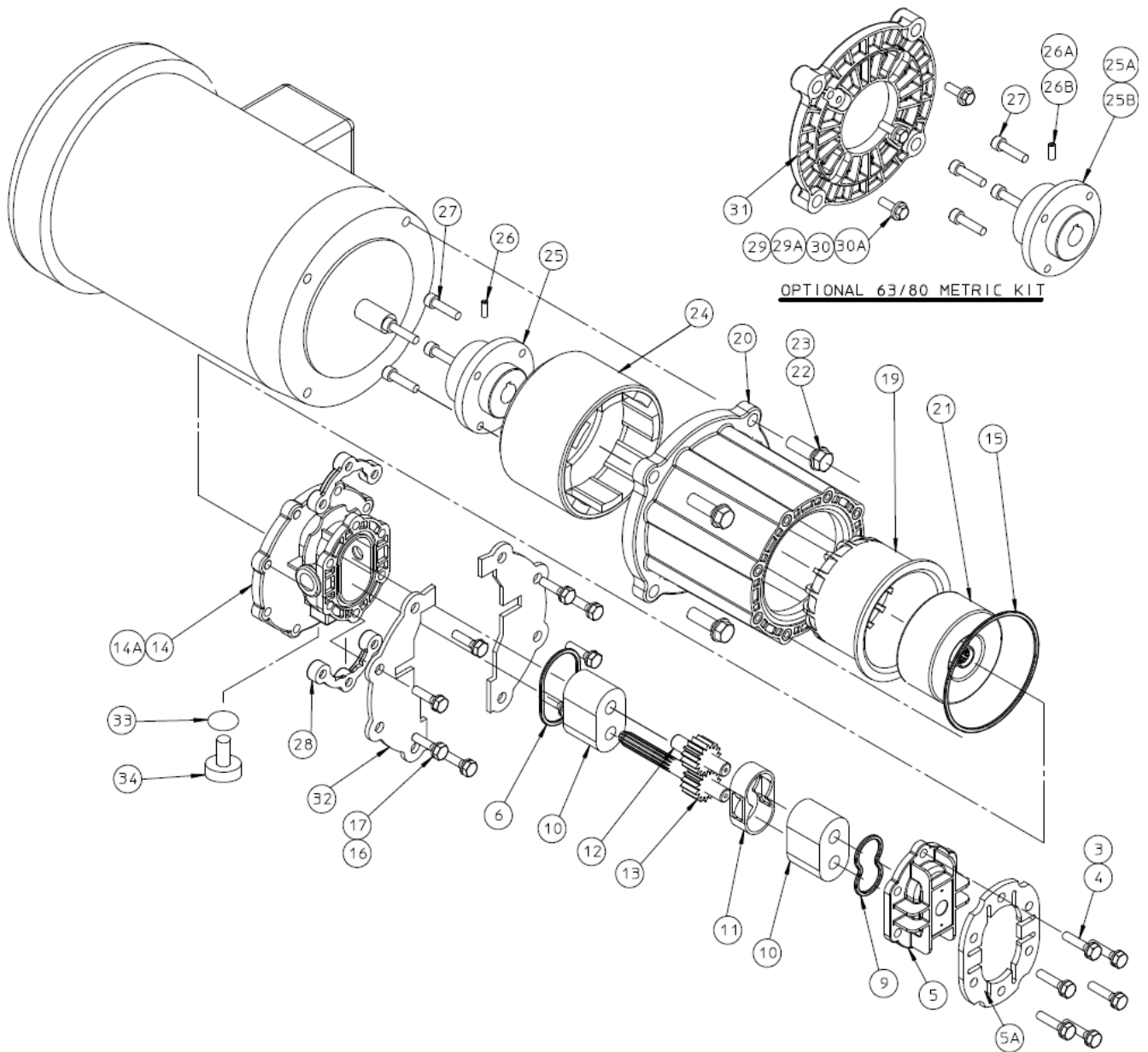

Eclipse Pump Series Size 05 Non-Metallic Parts Diagram Key

Position 1,2,3,4 - Base Pump Material/Ports

Item	Description	Quantity
N/S	Name Plate	1
2	Drive Screw	2
3	Bolt	6
4	Washer	6
5	Cover, Front	1
5A	Plate, Cover Reinforcement	1
14	Housing, Center FNPT	1
	Housing, Center BSPT	
16	Bolt	8
17	Washer	8
19	Can, Containment	1
20	Adapter, Spool	1
21	Driven Magnet Assembly	1
24	Drive Magnet	1
28	Plate, Nut	2
32	Plate, Reinforcement	2
34	Plug, Drain	1

Position 5 – Bearing Materials

Item	Description	Quantity
10	Bearing	2
	Bearing	2
11	Liner, Housing	1
12	Gear Assembly, Idler	1
13	Gear Assembly, Drive	1

Position 6 – O-Ring Material Selection

Item	Description	Quantity
6	O-ring Cover	1
9	O-ring Drain Plug	1
15	O-ring Containment Can	1
33	O-ring Compression	1

Position 7 - NEMA C-Face and IEC B34 Metric Frame Magnetic Coupling Arrangement 56C NEMA frame components

Item	Description	Quantity
22	Bolt	4
23	Washer	4
25	Coupling Hub	1
26	Set Screw	1
27	Screw	4
Motor Mount Kit #	E05XXXF	

143TC - 182C NEMA frame components

Item	Description	Qty
22	Bolt	4
23	Washer	4
25	Coupling Hub	1
26	Set Screw	1
27	Screw	4
Motor Mount Kit #	E05XXXO	

63 IEC B34 frame components

Item	Description	Qty
22	Bolt	4
23	Washer	4
25A	Coupling Hub	1
26A	Set Screw	1
27	Screw	4
29	Bolt	4
30	Washer	4
31	Adapter, Motor	1
Motor Mount Kit #	E05XXXH	

71 IEC B34 frame components

Item	Description	Qty
22	Bolt	4
23	Washer	4
25A	Coupling Hub	1
26A	Set Screw	1
27	Screw	4
29	Bolt	4
31	Adapter, Motor	1
Motor Mount Kit #	E02XXUJ	

80 IEC B34 frame components

Item	Description	Qty
22	Bolt	4
23	Washer	4
25B	Coupling Hub	1
26B	Set Screw	1
27	Screw	4
29A	Bolt	4
30A	Washer	4
31	Adapter, Motor	1
Motor Mount Kit #	E05XXXK	

KOPKit Suffix Selection Bill of Materials

Item	Description – LTE	Quantity
6	O-ring Cover	1
11	Liner, Housing	1
12	Gear Assembly, Liner	1
13	Gear Assembly, Drive	1

Item	Description – STD	Quantity
6	O-ring Cover	1
9	O-ring Compression	2
10	Bearing	2
11	Liner, Housing	1
12	Gear Assembly, Liner	1
13	Gear Assembly, Drive	1

Item	Description - PRO	Quantity
6	O-ring Cover	1
9	O-ring Compression	2
10	Bearing	2
11	Liner, Housing	1
12	Gear Assembly, Liner	1
13	Gear Assembly, Drive	1
16	Bolt	6

13. Parts Diagram and List, Eclipse 12 Non-Metallic

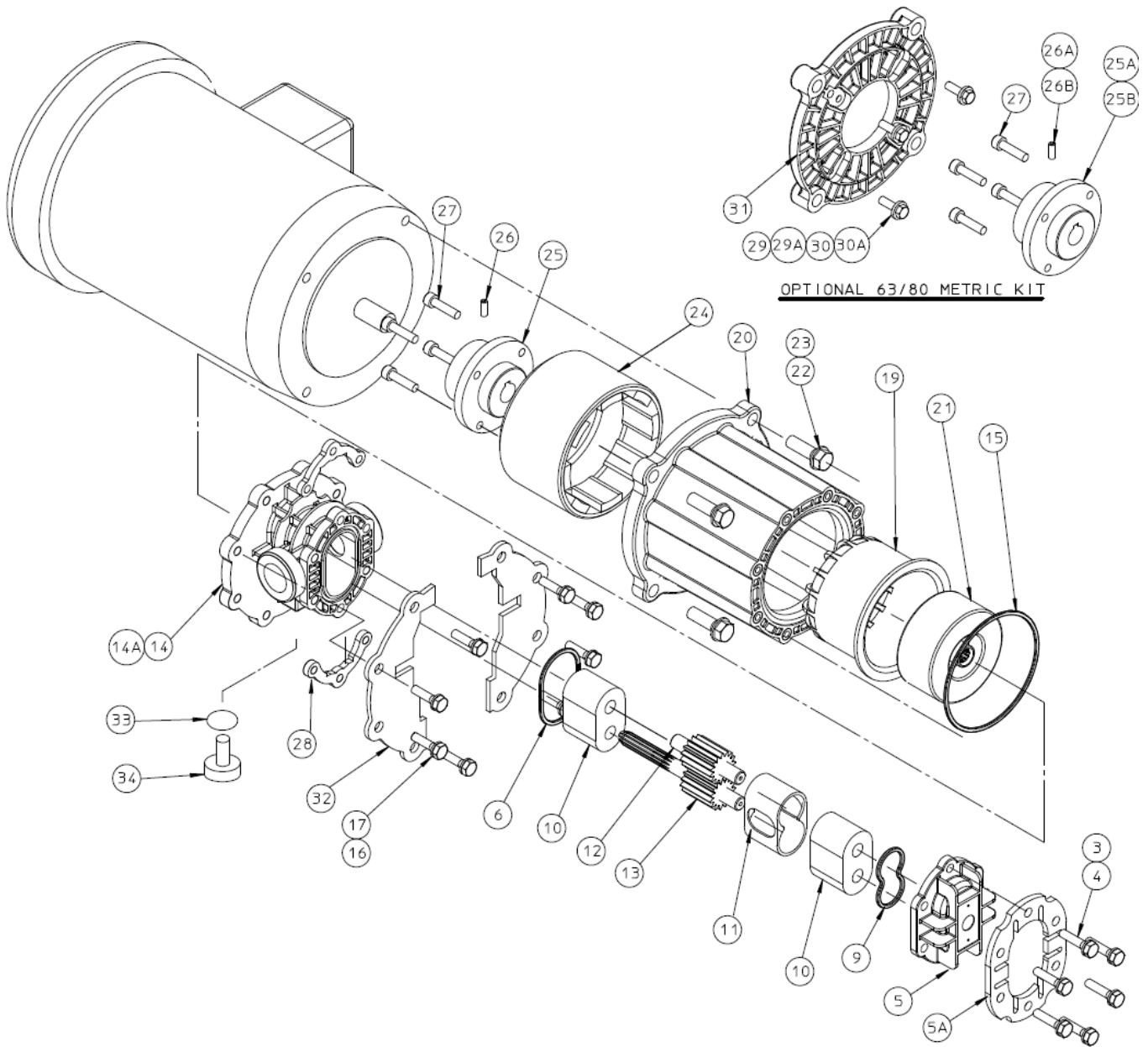

Eclipse Pump Series Size 12 Non-Metallic Parts Diagram Key

Position 1, 3, 3, 4 – Base Pump Material/Ports

Item	Description	Quantity
N/S	Name Plate	1
2	Drive Screw	2
3	Bolt	6
4	Washer	6
5	Cover, Front	1
5A	Plate, Cover Reinforcement	1
14	Housing, Center FNPT	1
	Housing, Center BSPT	
16	Bolt	8
17	Washer	8
19	Can, Containment	1
20	Adapter, Spool	1
21	Driven Magnet Assembly	1
24	Drive Magnet	1
28	Plate, Nut	2
32	Plate, Reinforcement	2
34	Plug, Drain	1

Position 5 – Bearing Materials

Item	Description	Quantity
10	Bearing	2
	Bearing	
11	Liner, Housing	1
12	Gear Assembly, Idler	1
13	Gear Assembly, Drive	1

Position 6 – O-ring Material Selection

Item	Description	Quantity
6	O-ring Cover	1
9	O-ring Drain Plug	1
15	O-ring Containment Can	1
33	O-ring Compression	1

Position 7 - NEMA C-Face and IEC B34 Metric Frame Magnetic Coupling Arrangement

56C NEMA frame components

Item	Description	Quantity
22	Bolt	4
23	Washer	4
25	Coupling Hub	1
26	Set Screw	1
27	Screw	4
Motor Mount Kit #	E12XXXF	

143TC - 182C NEMA frame components

Item	Description	Qty
22	Bolt	4
23	Washer	4
25	Coupling Hub	1
26	Set Screw	1
27	Screw	4
Motor Mount Kit #	E12XXXO	

**Optional Metric Motor Mounting Kit
63 IEC B34 frame components**

Item	Description	Qty
22	Bolt	4
23	Washer	4
25A	Coupling Hub	1
26A	Set Screw	1
27	Screw	4
29	Bolt	4
30	Washer	4
31	Adapter, Motor	1
Motor Mount Kit #	E12XXXH	

71 IEC B34 frame components

Item	Description	Qty
22	Bolt	4
23	Washer	4
25A	Coupling Hub	1
26A	Set Screw	1
27	Screw	4
29	Bolt	4
31	Adapter, Motor	1
Motor Mount Kit #	E12XXXJ	

80 IEC B34 frame components

Item	Description	Qty
22	Bolt	4
23	Washer	4
25B	Coupling Hub	1
26B	Set Screw	1
27	Screw	4
29A	Bolt	4
30A	Washer	4
31	Adapter, Motor	1
Motor Mount Kit #	E12XXXK	

KOPkit Suffix Selection Bill of Materials

Item	Description – LTE	Qty
6	O-ring Cover	1
11	Liner, Housing	1
12	Gear Assembly, Liner	1
13	Gear Assembly, Drive	1

Item	Description – STD	Qty
6	O-ring Cover	1
9	O-ring Compression	2
10	Bearing	2
11	Liner, Housing	1
12	Gear Assembly, Liner	1
13	Gear Assembly, Drive	1

Item	Description – PRO	Qty
3	Bolt	6
4	Washer	6
6	O-ring Cover	1
9	O-ring Compression	2
10	Bearing	2
11	Liner, Housing	1
12	Gear Assembly, Liner	1
13	Gear Assembly, Drive	1

14. Parts Diagram and List, Eclipse 25 Non-Metallic

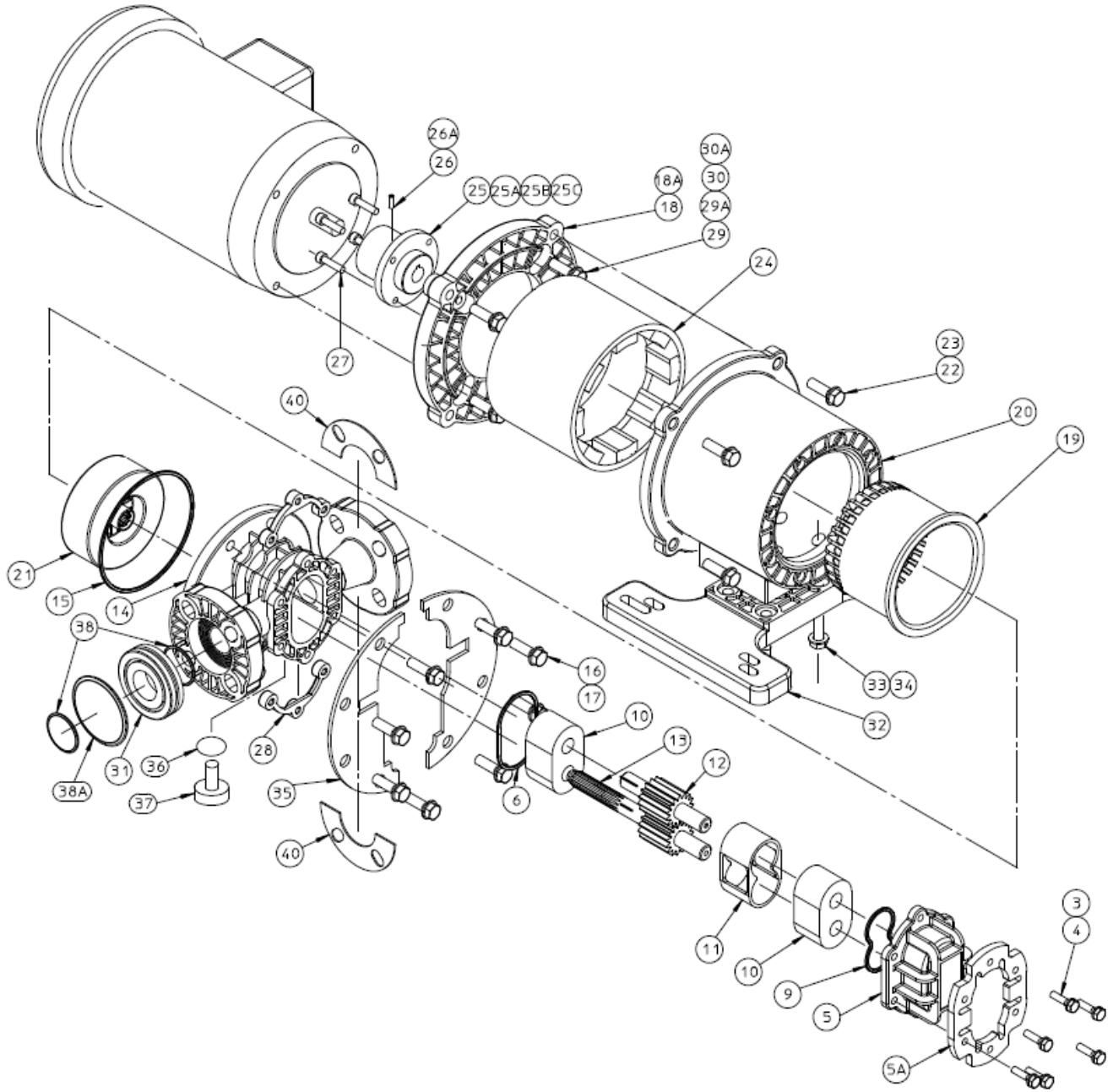

Eclipse Pump Series Size 25 Non-Metallic Parts Diagram Key

Position 1,2,3,4 – Base Pump Material/Port

Item	Description	Quantity
N/S	Name Plate	1
2	Drive Screw	2
3	Bolt	6
4	Washer	6
5	Cover, Front	1
5A	Plate, Cover Reinforcement	1
14	Housing, Center Flanged	1
16	Bolt	8
17	Washer	8
19	Can, Containment	1
20	Adapter, Spool	1
21	Driven Magnet Assembly	1
24	Drive Magnet	1
28	Plate, Nut	2
32	Base	1
33	Bolt	4
34	Washer	4
35	Plate, Reinforcement	2
37	Drain Plug	1
40	Plate, Flange Reinforcement	4

Position 5 – Bearing Materials

Item	Description	Quantity
10	Bearing	2
	Bearing	2
11	Liner, Housing	1
12	Gear Assembly, Idler	1
13	Gear Assembly, Drive	1

Position 6 – O-ring Material Selection

Item	Description	Quantity
6	O-ring Cover	1
9	O-ring Compression	1
15	O-ring Containment Can	1
31 / 38	Kit, Flange Gasket	2
36	O-ring Drain Plug	1

Position 7 - NEMA C-Face and IEC B34 Metric Frame Magnetic Coupling Arrangement

56C NEMA frame components

Item	Description	Quantity
18	Adaptor, Motor	1
22	Bolt	4
23	Washer	4
25	Coupling Hub	1
26	Set Screw	1
27	Screw	4
29	Bolt	4
30	Washer	4
Motor Mount Kit #	E25XXXXF	

143TC - 182C NEMA frame components

Item	Description	Quantity
18	Adaptor, Motor	1
22	Bolt	4
23	Washer	4
25	Coupling Hub	1
26	Set Screw	1
27	Screw	4
29	Bolt	4
30	Washer	4
Motor Mount Kit #	E25XXXO	

100/112 IEC B34 frame components

Item	Description	Quantity
18	Adaptor, Motor	1
22	Bolt	4
23	Washer	4
25A	Coupling Hub	1
26A	Set Screw	1
27	Screw	4
29A	Bolt	4
30A	Washer	4
Motor Mount Kit #	E25XXXP	

80 IEC B34 frame components

Item	Description	Quantity
18	Adaptor, Motor	1
22	Bolt	4
23	Washer	4
25A	Coupling Hub 80	1
26A	Set Screw	1
27	Screw	4
29A	Bolt	4
30A	Washer	4
Motor Mount Kit #	E25XXXX	

90 IEC B34 frame components

Item	Description	Quantity
18	Adaptor, Motor	1
22	Bolt	4
23	Washer	4
25A	Coupling Hub 80	1
26A	Set Screw	1
27	Screw	4
29A	Bolt	4
30A	Washer	4
Motor Mount Kit #	E25XXXL	

KOPkit Suffix Selection Bill of Materials

Item	Description – LTE	Quantity
6	O-ring Cover	1
11	Liner, Housing	1
12	Gear Assembly, Liner	1
13	Gear Assembly, Drive	1

Item	Description – STD	Quantity
6	O-ring Cover	1
9	O-ring Compression	2
10	Bearing	2
11	Liner, Housing	1
12	Gear Assembly, Liner	1
13	Gear Assembly, Drive	1

Item	Description – PRO	Quantity
3	Bolt	6
4	Washer	6
6	O-ring Cover	1
9	O-ring Compression	2
10	Bearing	2
11	Liner, Housing	1
12	Gear Assembly, Liner	1
13	Gear Assembly, Drive	1
28	Plate, Nut	2

15. Parts Diagram and List, Eclipse 75 Non-Metallic

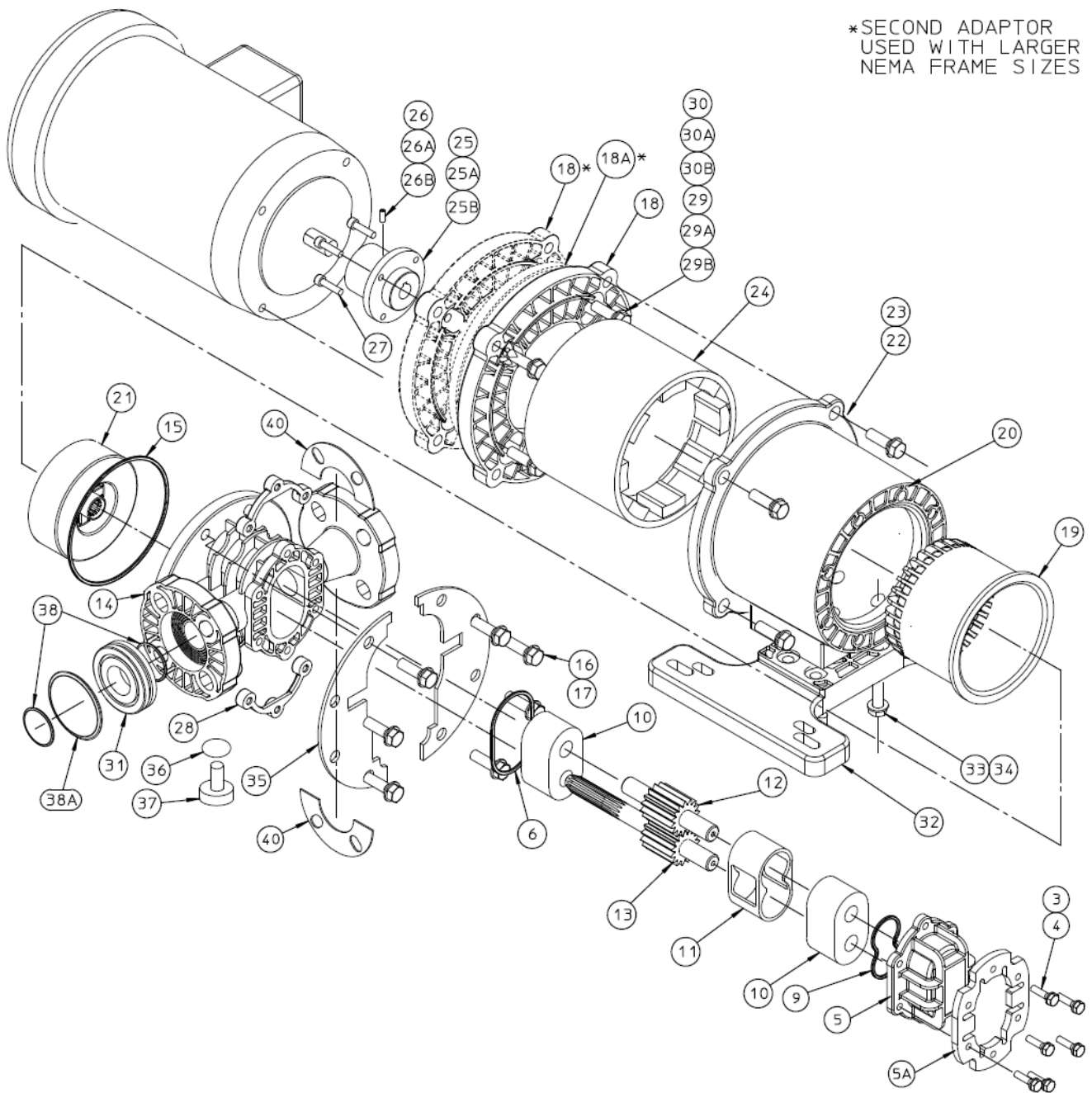

*SECOND ADAPTOR
USED WITH LARGER
NEMA FRAME SIZES

Eclipse Pump Series Size 75 Non-Metallic Consolidated Bill of Material

Position 1,2,3,4 - Base Pump Material/Ports

Item	Description	Quantity
N/S	Name Plate	1
2	Drive Screw	2
3	Bolt	6
4	Washer	6
5	Cover, Front	1
5A	Plate, Cover Reinforcement	1
14	Housing, Center Flanged	1
16	Bolt	8
17	Washer	8
19	Can, Containment	1
21	Driven Magnet Assembly	1
24	Drive Magnet	1
28	Plate, Nut	2
31	Gasket, Flange	2
32	Base	1
33	Bolt	4
34	Washer	4
35	Plate, Reinforcement	2
37	Drain Plug	1
40	Plate, Flange Reinforcement	4

Position 5 - Bearing Materials

Item	Description	Quantity
10	Bearing	2
	Bearing	2
11	Liner, Housing	1
12	Gear Assembly, Idler	1
13	Gear Assembly, Drive	1

Position 6 - O-ring Material Selection

Item	Description	Quantity
6	O-ring Cover	1
9	O-ring Compression	1
15	O-ring Containment Can	1
31 / 38	Kit, Flange Gasket	2
36	O-ring Drain Plug	1

Position 7 - NEMA C-Face and IEC B3/14 Metric Frame Magnetic Coupling Arrangement 56C frame components

Item	Description	Quantity
18	Adaptor	1
22	Bolt	4
23	Washer	4
25A	Coupling Hub	1
26A	Set Screw	1
27	Screws	4
29A	Bolts	4
30A	Washers	4
Motor Mount Kit #	E75XXXF	

143TC - 182C NEMA frame components

Item	Description	Quantity
18	Adapter, Motor	1
22	Bolt	4
23	Washer	4
25A	Coupling Hub	1
26A	Set Screw	1
27	Screw	4
29A	Bolt	4
30A	Washer	4
Motor Mount Kit #	E75XXXO	

182TC - 184TC NEMA frame components

Item	Description	Quantity
18	Adapter, Motor	1
22	Bolt	4
23	Washer	4
25	Coupling Hub	1
26	Set Screw	1
27	Screw	4
29	Bolt	4
30	Washer	4
Motor Mount Kit #	E75XXXR	

213TC - 215TC NEMA frame components

Item	Description	Quantity
18	Adapter, Motor	2
18A	Mate, Motor Adaptor	1
22	Bolt – spool	4
23	Washer – spool	4
25B	Coupling Hub	1
26B	Set Screw	1
27	Screw	4
29	Bolt (motor)	4
30	Washer (motor)	4
Motor Mount Kit #	E75XXXW	

80 IEC B14/B34 frame components

Item	Description	Quantity
18	Adaptor, Motor	1
22	Bolt	4
23	Washer	4
25A	Coupling Hub 80	1
26A	Set Screw	1
27	Screw	4
29A	Bolt	4
30A	Washer	4
Motor Mount Kit #	E75XXXK	

90 IEC B14/B34 frame components

Item	Description	Quantity
18	Adaptor, Motor	1
22	Bolt	4
23	Washer	4
25A	Coupling Hub 80	1
26A	Set Screw	1
27	Screw	4
29A	Bolt	4
30A	Washer	4
Motor Mount Kit #	E75XXXL	

100/112 IEC B14/B34 frame components

Item	Description	Quantity
18	Adapter, Motor	1
22	Bolt	4
23	Washer	4
25B	Coupling Hub	1
26B	Set Screw	1
27	Screw	4
29B	Bolt	4
30B	Washer	4
Motor Mount Kit #	E75XXXXP	

132 IEC B14/B34 frame components

Item	Description	Quantity
18	Adapter, Motor	1
22	Bolt	4
23	Washer	4
25B	Coupling Hub	1
26B	Set Screw	1
27	Screw	4
29B	Bolt	4
30B	Washer	4
Motor Mount Kit #	E75XXXXV	

KOPKit Suffix Selection Bill of Materials

Item	Description – LTE	Quantity
6	O-ring Cover	1
11	Liner, Housing	1
12	Gear Assembly, Liner	1
13	Gear Assembly, Drive	1

Item	Description – STD	Quantity
6	O-ring Cover	1
9	O-ring Compression	2
10	Bearing	2
11	Liner, Housing	1
12	Gear Assembly, Liner	1
13	Gear Assembly, Drive	1

Item	Description – PRO	Quantity
3	Bolt	6
4	Washer	6
6	O-ring Cover	1
9	O-ring Compression	2
10	Bearing	2
11	Liner, Housing	1
12	Gear Assembly, Liner	1
13	Gear Assembly, Drive	1
28	Plate, Nut	2

16. Parts Diagram and List, Eclipse 125 Non-Metallic

*SECOND ADAPTOR
USED WITH LARGER
NEMA FRAME SIZES

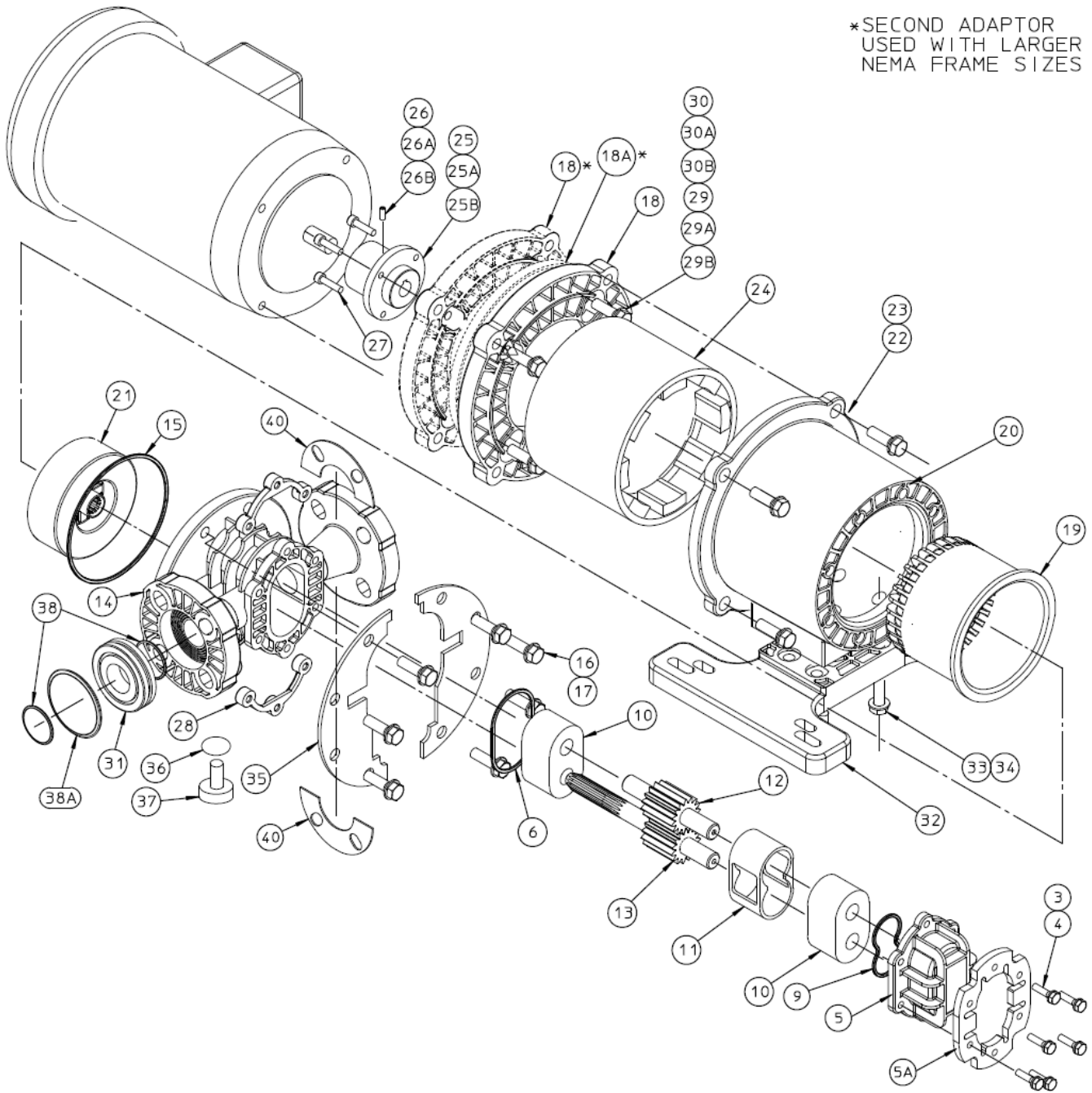

Eclipse Pump Series Size 125 Non-Metallic Parts Diagram Key

Position 1,2,3,4 – Base Pump Material/Ports

Item	Description	Quantity
N/S	Name Plate	1
2	Drive Screw	2
3	Bolt	6
4	Washer	6
5	Cover, Front	1
5A	Plate, Cover Reinforcement	1
14	Housing, Center Flanged	1
16	Bolt	8
17	Washer	8
19	Can Containment	1
20	Adapter, Spool	1
24	Drive Magnet	1
28	Plate, Nut	2
31	Gasket, Flange	2
32	Base	1
33	Bolt	4
34	Washer	4
35	Plate, Reinforcement	2
37	Drain Plug	1
40	Plate, Flange Reinforcement	4

Position 5 - Bearing Materials

Item	Description	Quantity
10	Bearing	2
	Bearing	2
11	Liner, Housing	1
12	Gear Assembly, Idler	1
13	Gear Assembly, Drive	1

Position 6 - O-ring Material Selection

Item	Description	Quantity
6	O-ring Cover	1
9	O-ring Compression	1
15	O-ring Containment Can	1
31 / 38	Kit, Flange Gasket	2
36	O-ring Drain Plug	1

Position 7 - NEMA C-Face and IEC B3/14 Metric Frame Magnetic Coupling Arrangement

143TC - 182C NEMA frame components

Item	Description	Quantity
18	Adapter, Motor	1
22	Bolt	4
23	Washer	4
25A	Coupling Hub	1
26A	Set Screw	1
27	Screw	4
29A	Bolt	4
30A	Washer	4
Motor Mount Kit #	E125XXXO	

182TC - 184TC NEMA frame components

Item	Description	Quantity
18	Adapter, Motor	1
22	Bolt (spool)	4
23	Washer (base)	4
25	Coupling Hub	1
26	Set Screw	1
27	Screw	4
29	Bolt (motor)	4
30	Washer (motor)	4
Motor Mount Kit #	E125XXXR	

213TC - 215TC NEMA frame components

Item	Description	Quantity
18	Adapter, Motor	2
18A	Mate, Motor Adaptor	1
22	Bolt – spool	4
23	Washer - spool	4
25B	Coupling Hub	1
26B	Set Screw	1
27	Screw	4
29	Bolt (motor)	4
30	Washer (motor)	4
Motor Mount Kit #	E125XXXW	

100/112 IEC B14 frame components

Item	Description	Quantity
18	Adapter, Motor	1
22	Bolt – spool	4
23	Washer - base	4
25B	Coupling Hub	1
26B	Set Screw	1
27	Screw	4
29B	Bolt – motor	4
30B	Washer - motor	4
Motor Mount Kit #	E125XXXP	

132 IEC B14 frame components

Item	Description	Quantity
18	Adapter, Motor	1
22	Bolt – spool	4
23	Washer - base	4
25B	Coupling Hub	1
26B	Set Screw	1
27	Screw	4
29B	Bolt	4
30B	Washer	4
Motor Mount Kit #	E125XXXV	

KOPKit Suffix Selection Bill of Materials

Item	Description – LTE	Quantity
6	O-ring Cover	1
11	Liner, Housing	1
12	Gear Assembly, Liner	1
13	Gear Assembly, Drive	1

Item	Description – STD	Quantity
6	O-ring Cover	1
9	O-ring Compression	2
10	Bearing	2
11	Liner, Housing	1
12	Gear Assembly, Liner	1
13	Gear Assembly, Drive	1

Item	Description – PRO	Quantity
10	Bearing	2
11	Liner, Housing	1
13	Gear Assembly, Drive	1
12	Gear Assembly, Liner	1
6	O-ring Cover	1
9	O-ring Compression	2
3	Bolt	6
4	Washer	6
28	Plate, Nut	2

ECLIPSE METALLIC PUMPS

17. Disassembly/Assembly, Eclipse 02

 **WARNING** BEFORE PERFORMING ANY MAINTENANCE REQUIRING PUMP DISASSEMBLY, BE SURE TO RELIEVE PRESSURE FROM THE PIPING SYSTEM, ISOLATE THE PUMP FULLY USING THE APPROPRIATE SHUTOFF/BLOCKING DEVICES, AND, WHERE HAZARDOUS PROCESS MATERIALS ARE INVOLVED, RENDER THE PUMP SAFE TO PERSONNEL AND THE ENVIRONMENT BY CLEANING AND CHEMICALLY NEUTRALIZING AS APPROPRIATE. WEAR PROTECTIVE CLOTHING AND EQUIPMENT AS REQUIRED.

17.1 Disassembly

- Close all suction and discharge valves.
 - Disconnect power source to motor. Follow local Lockout/Tagout procedures.
 - Flush and drain pump
 - Remove piping (optional for KOPkit).
 - The can area will not fully drain and will contain some process fluid.
 - Refer to the Parts Diagram and List in **Section 12**.
1. Remove the motor mounting hardware and slide the entire pump straight off the motor (optional for KOPkit).

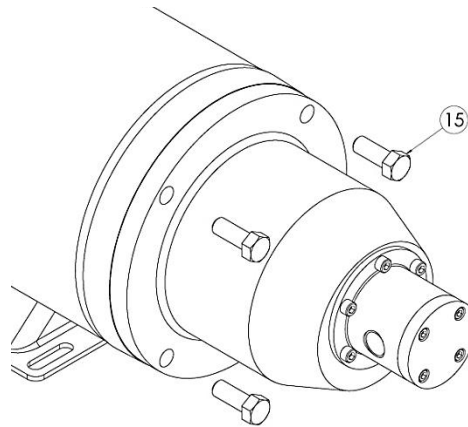

Figure 4 – Metallic

2. Place pump assembly (motor spool down) on the work surface.

3. Remove the front cover hardware and remove front cover as shown.

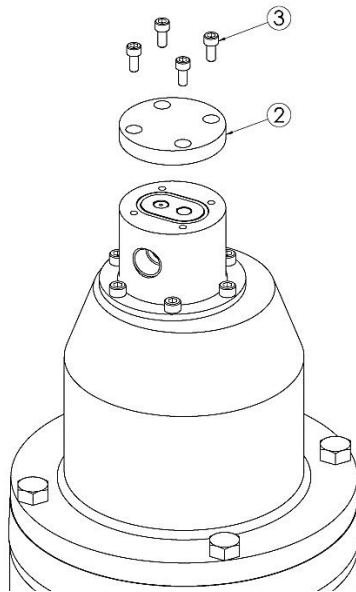

Figure 5 – Metallic

4. Remove bearings, gear/shaft assemblies, and housing liner as shown. These parts, along with the O-rings make up a standard Eclipse Series KOPkit. Check parts for wear and replace with a KOPkit as required.

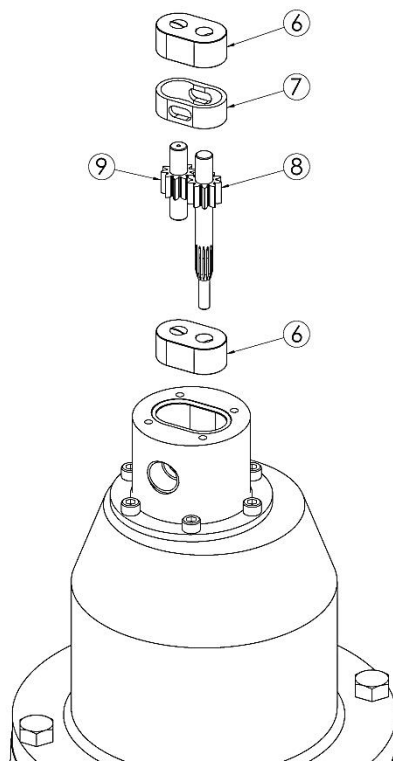

Figure 6 – Metallic

5. Remove the hardware to detach the center housing.

6. Remove the two O-rings from the center housing and front cover.

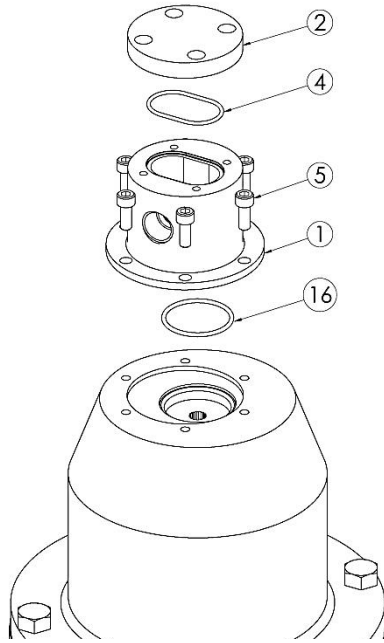

Figure 7 – Metallic

7. Remove the mounting hardware holding the adapter plate to the motor spool and detach the adapter plate. Metallic pumps do not have an adaptor plate, mounting bolts may be removed to detach from motor (if not already removed).
8. Remove driven magnet assembly and containment can from adapter plate or spool as shown.

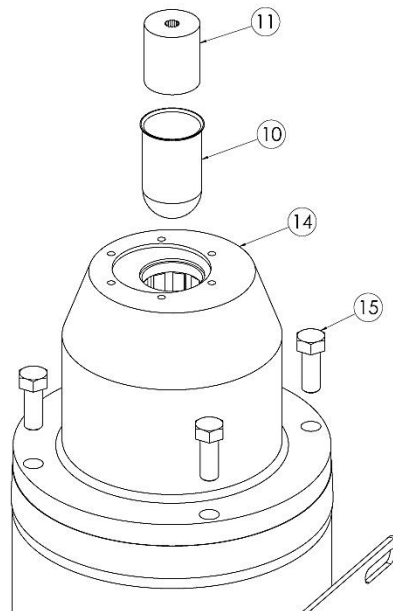

Figure 8 – Metallic



BE CAREFUL DURING DISASSEMBLY AND REASSEMBLY OF THE DRIVE AND DRIVEN MAGNET ASSEMBLIES. THE MAGNETIC ATTRACTION FORCES ARE HIGH, AND WHEN THE MAGNETS COME CLOSE TOGETHER THERE IS A STRONG TENDENCY TO SNAP TOGETHER SUDDENLY, POTENTIALLY CAUSING INJURY TO FINGERS OR FLESH.

8. Remove drive magnet assembly from the motor by loosening the setscrew in the magnet hub and slide off the motor shaft. Retain the key from the motor shaft.

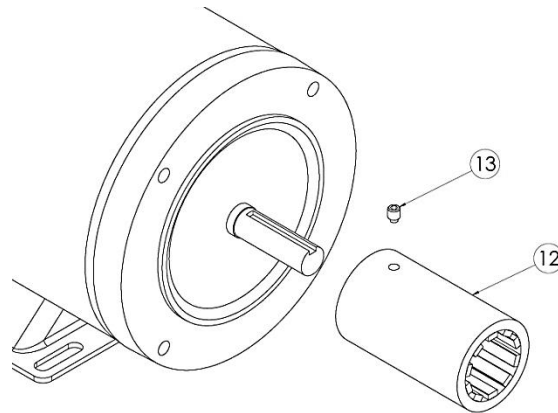

Figure 9 – Metallic

17.2 Assembly

1. Place motor spool flat on work surface. Set in place and install mounting bolts and washers. Tighten these bolts to the torque specified in **Section 29.2**. Always tighten fasteners in a progressive “crisscross” pattern.
2. Install the containment can into the spool or adapter plate until it is properly seated into the assembly.
3. Install the driven magnet assembly into the containment can; must have the spline end of the driven magnet facing out of the can.

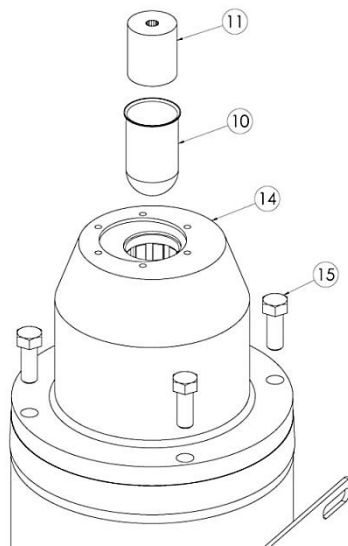

Figure 10 – Metallic

4. Inspect all O-rings to be sure there is no damage such as pinching prior to assembly.
5. Install O-rings into grooves on both sides of the center housing. Some O-ring lubricant may help keep the O-rings in place during assembly. Be sure both O-rings are fully seated into housing grooves.

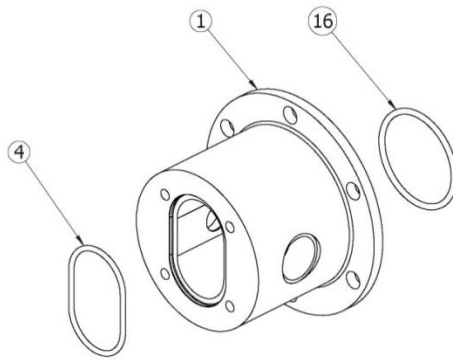

Figure 11 – Metallic

6. Place the center housing with O-rings installed onto the spool or adapter plate (open bore facing out), aligning the flat sides on the center housing to the flat sides on the spool adapter plate.
7. Secure the center housing using two bolts in holes. Tighten these bolts to the torque specified in **Section 29.2**. Always tighten fasteners in a progressive “crisscross” pattern.
8. Insert a bearing into the center housing and slide to the bottom of the housing. Bearings are symmetrical and orientation does not matter.
9. Install the housing liner and slide until it seats against the first bearing. Install the idler gear into the top hole in bearing until the gear seats against the first bearing.
10. Install the drive gear, splined-end first, into the assembly until it bottoms out against the bearing. The shaft may have to be rotated slightly to properly fit the splined-end into the drive magnet and gear to the idler gear assembly.
11. Insert the second bearing into the housing bore until it rests against the housing liner. Bearings are symmetrical and orientation does not matter.

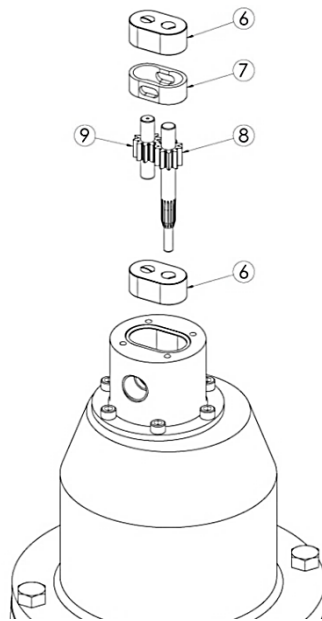

Figure 13 – Metallic

12. Install front cover. Tighten the bolts to the torque specified in **Section 29.2**. Always tighten fasteners in a progressive “crisscross” pattern.
13. Reinstall the ATEX grounding hardware as illustrated on **page 6, Figure A**.



BE CAREFUL DURING DISASSEMBLY AND REASSEMBLY OF THE DRIVE AND DRIVEN MAGNET ASSEMBLIES. THE MAGNETIC ATTRACTION FORCES ARE HIGH, AND WHEN THE MAGNETS COME CLOSE TOGETHER THERE IS A STRONG TENDENCY TO SNAP TOGETHER SUDDENLY, POTENTIALLY CAUSING INJURY TO FINGERS OR FLESH.

14. Align the keyway and slide the drive magnet onto the motor shaft until the end of the motor shaft is flush with face of the drive magnet motor or hub as shown in Figure 18. Secure with the setscrew. Application of a no-seize compound on the shaft and key will make future maintenance easier.

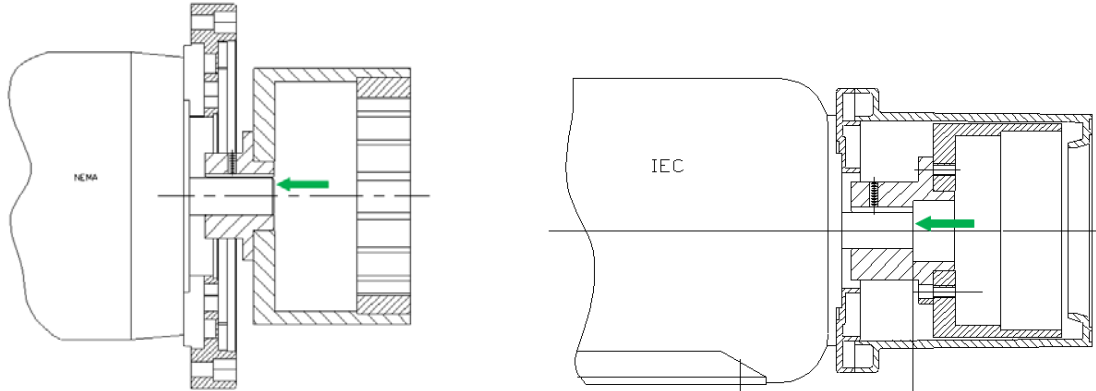



Figure 18

15. Complete assembly by replacing the assembled pump onto the motor, using care not to allow fingers to get pinched when the magnets attract. Secure the pump to the motor with the mounting hardware. Always tighten fasteners in a progressive “crisscross” pattern, following the Torque Specifications in **Section 29.2**.

18. Disassembly/Assembly, Eclipse 05/12 and Eclipse 25 Metallic

 **WARNING** BEFORE PERFORMING ANY MAINTENANCE REQUIRING PUMP DISASSEMBLY, BE SURE TO RELIEVE PRESSURE FROM THE PIPING SYSTEM, ISOLATE THE PUMP FULLY USING THE APPROPRIATE SHUTOFF/BLOCKING DEVICES, AND, WHERE HAZARDOUS PROCESS MATERIALS ARE INVOLVED, RENDER THE PUMP SAFE TO PERSONNEL AND THE ENVIRONMENT BY CLEANING AND CHEMICALLY NEUTRALIZING AS APPROPRIATE. WEAR PROTECTIVE CLOTHING AND EQUIPMENT AS REQUIRED.

18.1 Disassembly

- Close all suction and discharge valves.
 - Disconnect power source to motor. Follow local Lockout/Tagout procedures.
 - Flush and drain pump
 - Remove piping (optional for KOPkit).
 - The can area will not fully drain and will contain some process fluid.
 - Refer to the Parts Diagram and List in **Section 22, 23, and 24.**
1. Remove the motor mounting hardware and slide the entire pump straight off the motor (optional for KOPkit).

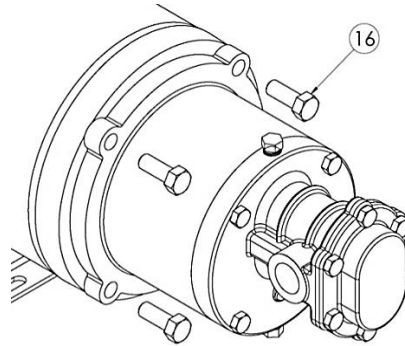

Figure 19 – Metallic E05/E12

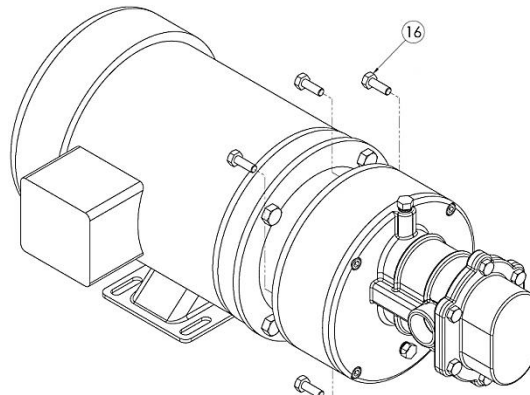

Figure 19 – Metallic E25

2. Place pump assembly (motor spool down) on the work surface.

3. Remove all the front cover hardware and remove front cover as shown.

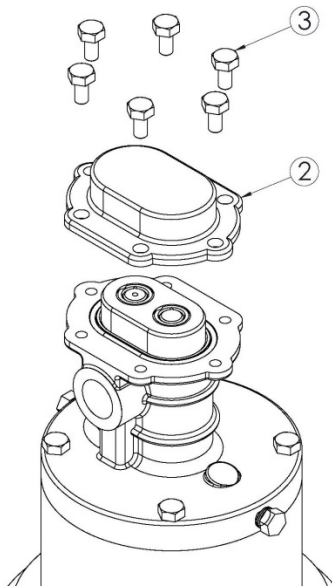

Figure 20 – Metallic

4. Remove bearings, gear/shaft assemblies, and housing liner as shown. These parts, along with the O-rings make up a standard Eclipse Series KOPkit. Check parts for wear and replace with a KOPkit as required.

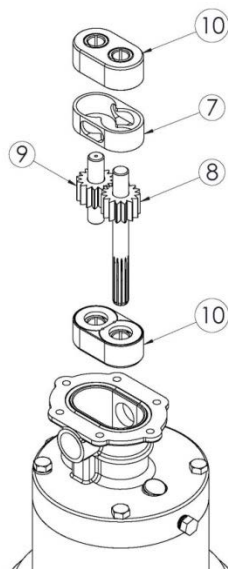

Figure 21 – Metallic

5. Remove the hardware holding the center housing to the motor spool. Remove the center housing and retaining plates for non-metallic pumps.

6. Remove all O-rings from the center housing and front cover. There are two O-rings in the center housing and one in the front cover as shown.

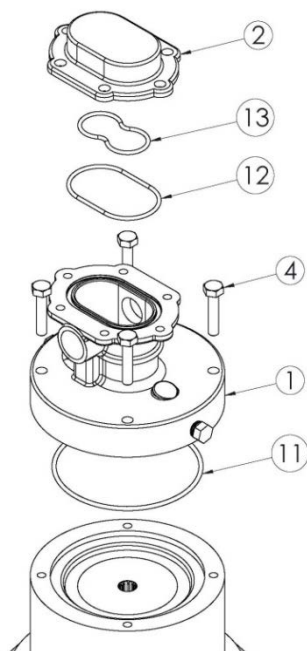

Figure 22 – Metallic

7. Remove driven magnet assembly and containment can from the motor spool.

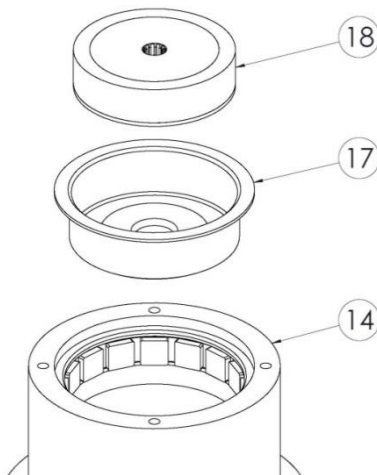

Figure 23 – Metallic



BE CAREFUL DURING DISASSEMBLY AND REASSEMBLY OF THE DRIVE AND DRIVEN MAGNET ASSEMBLIES. THE MAGNETIC ATTRACTION FORCES ARE HIGH, AND WHEN THE MAGNETS COME CLOSE TOGETHER THERE IS A STRONG TENDENCY TO SNAP TOGETHER SUDDENLY, POTENTIALLY CAUSING INJURY TO FINGERS OR FLESH.

8. Remove drive magnet assembly from the motor by loosening the setscrew in the magnet hub and slide off the motor shaft. Retain the key from the motor shaft.
9. For E25 metallic pumps, the motor adaptor (item 14) must be removed first. Loosen the set screw in drive magnet assembly through the motor spool (item 19)

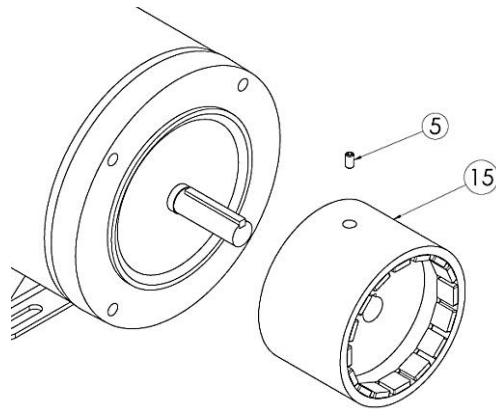

Figure 24 – Metallic E05/E12

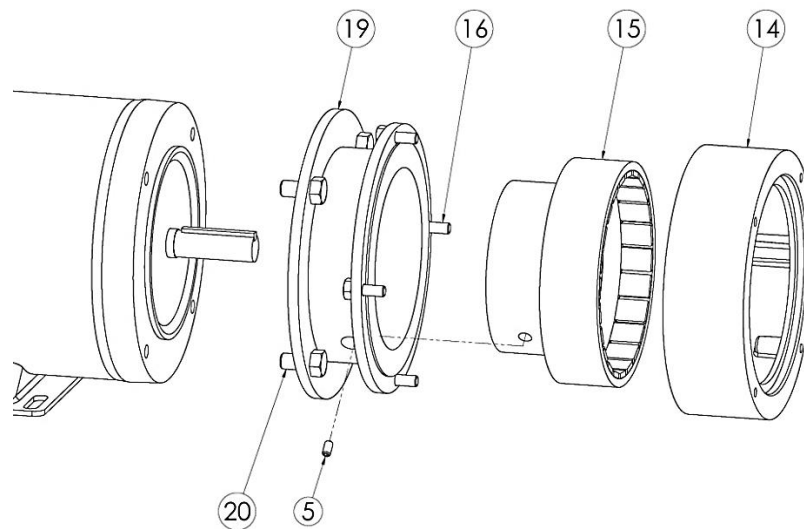

Figure 24 – Metallic E25



WARNING

BE CAREFUL DURING DISASSEMBLY AND REASSEMBLY OF THE DRIVE AND DRIVEN MAGNET ASSEMBLIES. THE MAGNETIC ATTRACTION FORCES ARE HIGH, AND WHEN THE MAGNETS COME CLOSE TOGETHER THERE IS A STRONG TENDENCY TO SNAP TOGETHER SUDDENLY, POTENTIALLY CAUSING INJURY TO FINGERS OR FLESH.

18.2 Assembly

1. Place motor spool or adaptor flat on work surface.
2. Insert the containment can and driven magnet into the motor spool as shown. Metallic pump driven magnets must be installed with the short hub side facing the drive magnet.

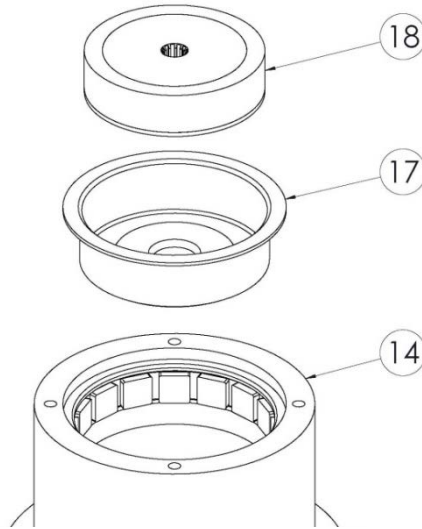

Figure 25 – Metallic

3. Inspect all O-rings to be sure there is no damage such as pinching prior to assembly.
4. Install O-rings into each side of the center housing as shown. Some o-ring lubricant may help keep the O-rings in place during assembly. Be sure both O-rings are fully seated into housing grooves.

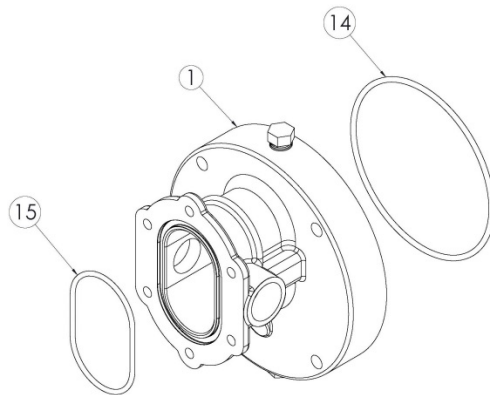

Figure 26 – Metallic

5. Place the center housing, with O-rings, onto the motor spool or adaptor, aligning the port connections between any set of motor spool bolt holes as shown. Tighten these bolts to the torque specified in **Section 29.2**. Always tighten fasteners in a progressive “crisscross” pattern.

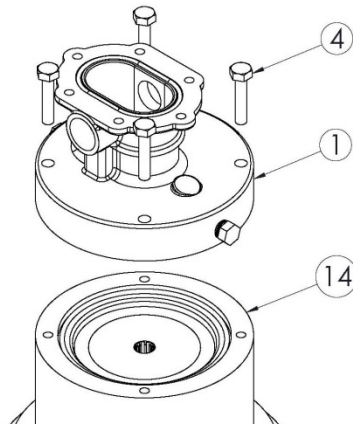

Figure 27 – Metallic

6. Insert a bearing into center housing and slide to bottom of bore. Pump bearings are symmetrical and orientation does not matter. Install the housing liner and slide until it seats against the first bearing.
7. Install the idler gear, splined-end first, into the assembly until it bottoms out against the bearing or wear plate. The shaft may have to be rotated slightly to properly fit the splined-end into the drive magnet and mesh gear teeth with the idler gear.
8. Insert the second bearing into the housing bore until it rests against the housing liner.

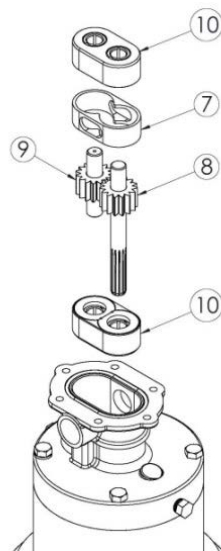

Figure 28 – Metallic

- Install the spacer O-ring into the front cover as shown. Some O-ring lubricant may help keep the O-rings in place during assembly.

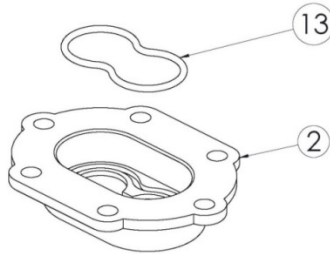

Figure 29 – Metallic

- Place the front cover with O-ring onto the assembled pump. Secure with the front cover hardware. Tighten these bolts to the torque specified in **Section 29.2**. Always tighten fasteners in a progressive “crisscross” pattern.
- Reinstall the ATEX grounding hardware as illustrated on **page 6, Figure A**.

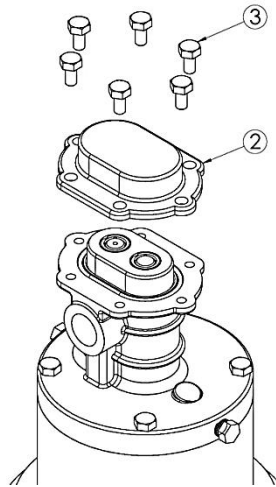

Figure 30 – Metallic

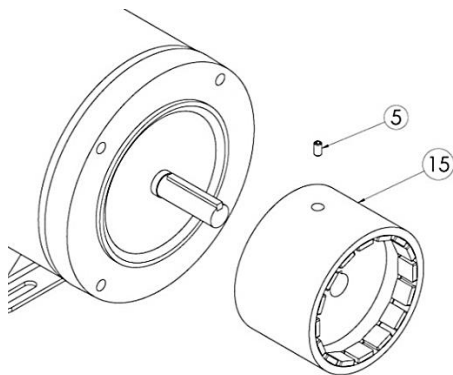

Figure 32 – Metallic

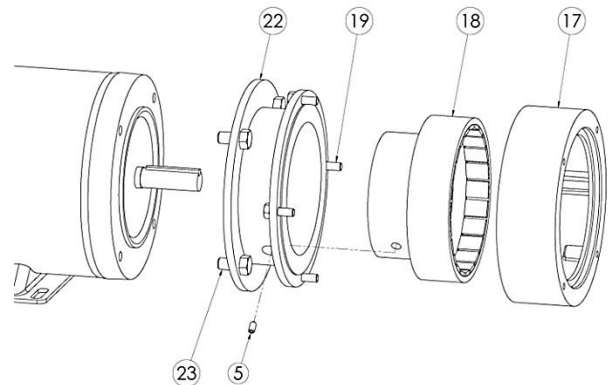

Figure 32 – Metallic E25



BE CAREFUL DURING DISASSEMBLY AND REASSEMBLY OF THE DRIVE AND DRIVEN MAGNET ASSEMBLIES. THE MAGNETIC ATTRACTION FORCES ARE HIGH, AND WHEN THE MAGNETS COME CLOSE TOGETHER THERE IS A STRONG TENDENCY TO SNAP TOGETHER SUDDENLY, POTENTIALLY CAUSING INJURY TO FINGERS OR FLESH.

12. Align the keyway, and slide the drive magnet onto the motor shaft until the end of the motor shaft aligns with faces of the drive magnet motor hub as shown below. Secure with the setscrew. Application of a no-seize compound on the shaft and key will make future maintenance easier.

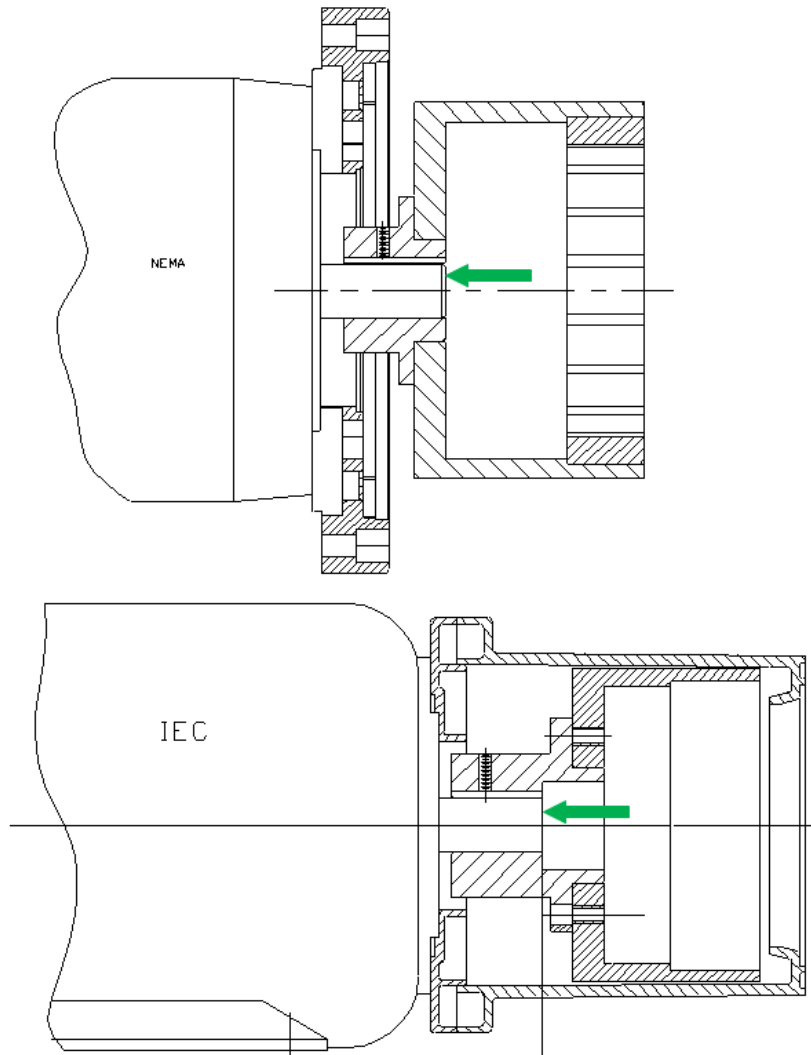

Figure 33

13. Complete assembly by replacing the assembled pump onto the motor, using care not to allow fingers to get pinched when the magnets attract. Secure the pump to the motor with the four bolts and washers. Always tighten fasteners in a progressive “crisscross” pattern.

19. Disassembly/Assembly, Eclipse 75/125 Metallic



WARNING

BEFORE PERFORMING ANY MAINTENANCE REQUIRING PUMP DISASSEMBLY, BE SURE TO RELIEVE PRESSURE FROM THE PIPING SYSTEM, ISOLATE THE PUMP FULLY USING THE APPROPRIATE SHUTOFF/BLOCKING DEVICES, AND, WHERE HAZARDOUS PROCESS MATERIALS ARE INVOLVED, RENDER THE PUMP SAFE TO PERSONNEL AND THE ENVIRONMENT BY CLEANING AND CHEMICALLY NEUTRALIZING AS APPROPRIATE. WEAR PROTECTIVE CLOTHING AND EQUIPMENT AS REQUIRED.



NOTE

Eclipse Metallic 75/125 Power frames are shipped without oil. Use Standard motor oil: SAE 10W-30, 10W-40, or 5W-30.

19.1 Disassembly

- Close all suction and discharge valves.
 - Disconnect power source to motor. Follow local Lockout/Tagout procedures.
 - Flush and drain pump
 - Remove piping (optional for KOPkit).
 - The can area will not fully drain and will contain some process fluid
 - Refer to the Parts Diagram and List in **Section 25 and 26**.
1. Remove the motor mounting hardware and slide the entire pump straight off the motor (optional for KOPkit).

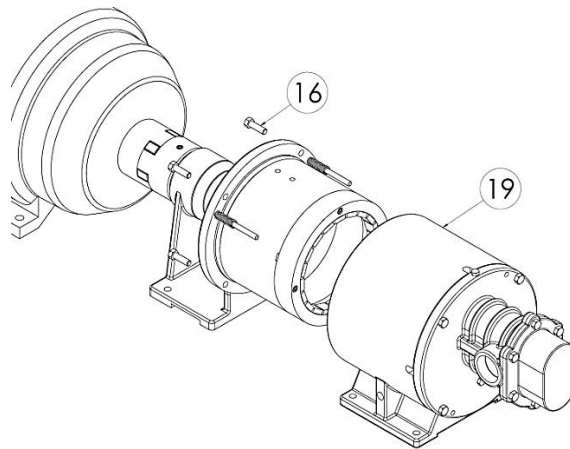

Figure 34 – Metallic

2. Place pump assembly (motor spool down) on the work surface. Remove the front cover hardware and remove front cover as shown.

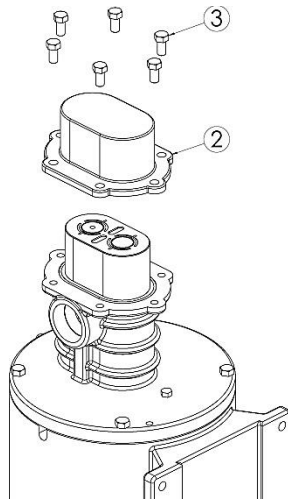

Figure 35 – Metallic

3. Remove bearings, gear/shaft assemblies, and housing liner as shown. These parts, along with the O-rings make up a standard Eclipse Series KOPkit. Check parts for wear and replace with a KOPkit as required.
4. Remove the hardware holding the center housing to the motor spool or power frame housing. Detach the center housing and retaining plates for non-metallic pumps.
5. Remove all O-rings from the center housing and front cover. There is one o-ring in the center housing and two in the front cover as shown.

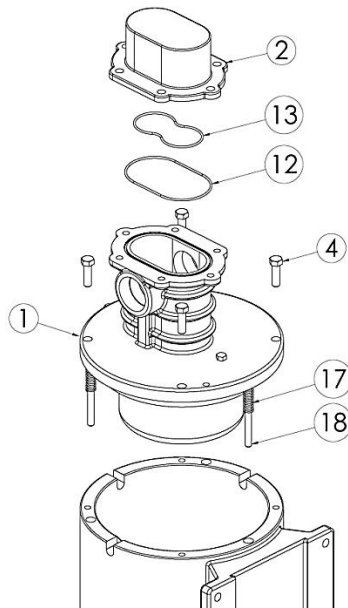

Figure 37 – Metallic

6. Metallic pumps require the removal of the containment can ring (item 25) and hardware to access the center housing o-ring and driven magnet.

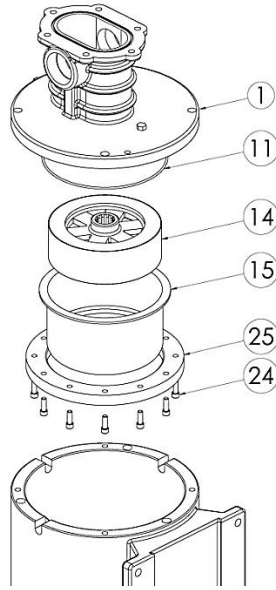

Figure 38 - Metallic

7. Remove drive magnet assembly from the motor by loosening the two setscrews in the magnet hub and slide off the motor shaft. Retain the key from the motor shaft.
8. The magnet hub can be separated from the drive magnet by removing the four screws and detaching.



BE CAREFUL DURING DISASSEMBLY AND REASSEMBLY OF THE DRIVE AND DRIVEN MAGNET ASSEMBLIES. THE MAGNETIC ATTRACTION FORCES ARE HIGH, AND WHEN THE MAGNETS COME CLOSE TOGETHER THERE IS A STRONG TENDENCY TO SNAP TOGETHER SUDDENLY, POTENTIALLY CAUSING INJURY TO FINGERS OR FLESH.

19.2 Assembly

1. Place motor spool or adaptor flat on work surface.
2. Install O-ring (item 15) into the back side of the center housing (item 14) as shown. Some O-ring lubricant may help keep O-rings in place during assembly. Be sure the O-ring is fully seated into housing groove.
3. Insert the driven magnet (item 14) with the small hub facing out of the containment can (item 15).
4. Install O-ring (item 11) into the back side of the center housing (item 1). Some O-ring lubricant may help keep O-rings in place during assembly.

- Then install the can and magnet with the containment can ring (item 25) and bolts (item 24) onto the center housing.

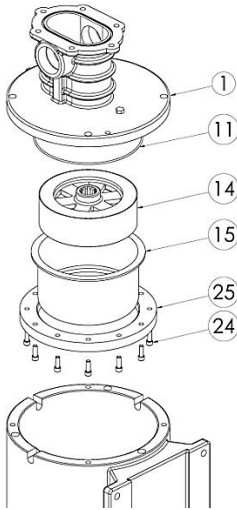

Figure 40 – Metallic

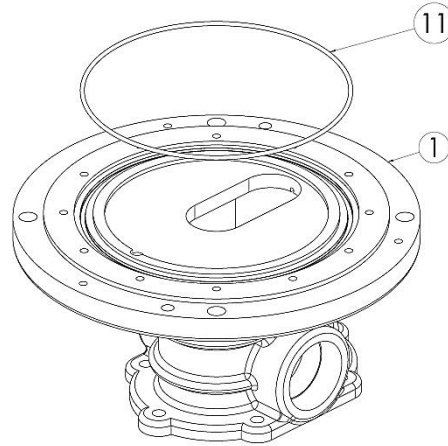

Figure 41 – Metallic



Inspect all O-rings to be sure there is no damage such as pinching prior to assembly.

- Place the center housing onto the motor spool or adaptor, aligning the port connections with the pump baseplate as shown. Install the pins and springs (items 18, 17) if removed from metallic pumps. Secure with center housing hardware. Tighten bolts to the torque specified in **Section 29.2**. Always tighten fasteners in a progressive “crisscross” pattern.
- Insert a bearing into center housing and slide to bottom of bore. Bearings are symmetrical and orientation does not matter. Install the housing liner and slide until it seats against the first bearing. Install idler gear into the top hole in the bearing until the gear seats against the first bearing.
- Install the drive gear splined-end first into the assembly until it bottoms out against the bearing. The shaft may have to be rotated slightly to properly fit the splined-end into the drive magnet and mesh gear teeth with the idler gear.
- Insert the second bearing into the housing bore until it rests against the housing liner. Bearings are symmetrical and orientation does not matter.

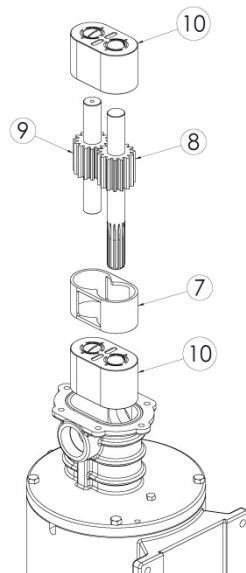

Figure 43 – Metallic

10. Install the two O-rings into the front cover and center housing (metallic only) as shown. Some o-ring lubricant may help keep the O-rings in place during assembly.

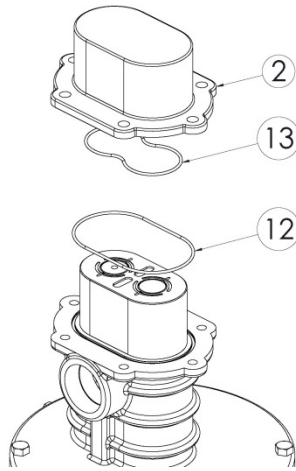

Figure 44 – Metallic

11. Place the front cover with O-ring onto the assembled pump. Secure with the front cover hardware. Tighten bolts to the torque specified in **Section 29.2**. Always tighten fasteners in a progressive “crisscross” pattern.
12. Reinstall the ATEX grounding hardware as illustrated on **page 6, Figure A**.
13. Secure the magnet hub to the drive magnet using the four screws. Always tighten fasteners in a progressive “crisscross” pattern.

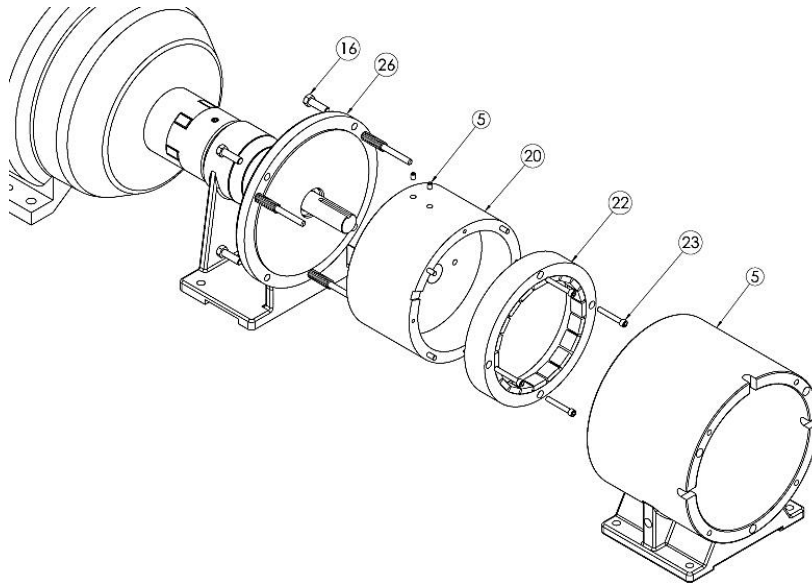

Figure 46 – Metallic



BE CAREFUL DURING DISASSEMBLY AND REASSEMBLY OF THE DRIVE AND DRIVEN MAGNET ASSEMBLIES. THE MAGNETIC ATTRACTION FORCES ARE HIGH, AND WHEN THE MAGNETS COME CLOSE TOGETHER THERE IS A STRONG TENDENCY TO SNAP TOGETHER SUDDENLY, POTENTIALLY CAUSING INJURY TO FINGERS OR FLESH.



Eclipse Metallic 75/125 Power frames are shipped without oil. Use Standard motor oil: SAE 10W-30, 10W-40, or 5W-30.

14. Align the keyway, and slide the drive magnet onto the motor shaft until the end of the motor shaft aligns with faces of the drive magnet motor hub as shown below. Secure with the setscrew (two for metallic pumps). Application of a no-seize compound on the shaft and key will make future maintenance easier.
15. Complete assembly by replacing the assembled pump onto the motor or power frame, using care not to allow fingers to get pinched when the magnets attract. Secure the pump with the appropriate hardware. Always tighten fasteners in a progressive “crisscross” pattern.

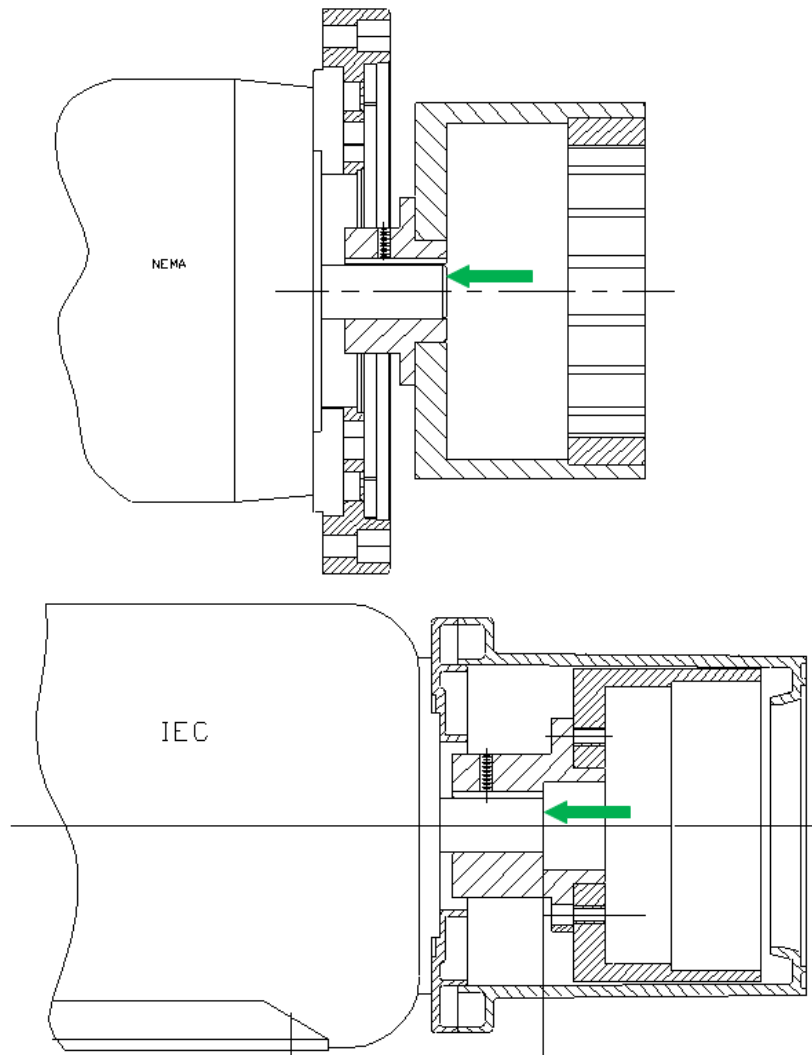

Figure 47

20. Pump Model Identification – Metallic

Position	Code	Specifies	Options	Available Pump Size
1	E	Model	E – Eclipse**	All
2 and 3	02, 05, 12, 25, 75, 125	Pump Size	02 – Max. Capacity .4 gpm (1.5 lpm) 05 – Max. Capacity 1.7 gpm (6.3 lpm) 12 – Max. Capacity 3.4 gpm (12.9 lpm) 25 – Max. Capacity 7.4 gpm (28.0 lpm) 75 – Max Capacity 22 gpm (83.3 lpm) 125 – Max Capacity 33 gpm (125 lpm)	
4	A, G, C, J U, V	Base Material	A – 316LSS, FNPT G – 316LSS, BSPT, ISO 7-1 C – ALLOY C, FNPT S – ALLOY C, BSPT, ISO 7-1 U – 316LSS, FLANGED V – ALLOY C, FLANGED	02, 05, 12, 25, 75, 125 02, 05, 12, 25, 75, 125 02, 05, 12*, 25*, 75*, 125* 02, 05, 12*, 25*, 75*, 125* 05, 12, 25, 75, 125 05, 12*, 25*, 75*, 125*
5	L, B	Bearings	L – Carbon-92 B – Silicon Carbide T – Glass Filled Teflon	All All All
6	U, K	O-rings	U – PTFE K – Kalrez Grade 4079	All All
7	F, O, H, J K, L, R, U	Motor Mounting	F – NEMA 56C O – NEMA 143/5TC-182/4C H – IEC 63 B3/B14 J – IEC 71 B3/B14 K – IEC 80 B3/B14 L – IEC 90 B3/B14 R – Pedestal w/1.125" shaft (182-4T or 213-5T) U – Pedestal w/ 28mm shaft (IEC 100/112 B3)	02, 05, 12, 25 05, 12, 25 02 02, 05, 12 05, 12, 25 25 75, 125 75, 125
8	-	Dash		All
9	S, F, B, A, C, V, D, E, T, G, P, H, J, K	Drive Shaft/Gear, Idler Shaft/Gear, Magnet Material	S – 316L/CFTFE ¹ , 316L/ CFTFE ¹ , SC ² , ND ² F – 316L/316L, 316L/TFE ¹ , SC ² , ND ² B – ALA ⁴ / CFTFE ¹ , ALA ⁴ / CFTFE ¹ , SC ² , ND ² A – Alloy C/ CFTFE ¹ , Alloy C/ CFTFE ¹ , SC ² , ND ² C – Alloy C/Alloy C, Alloy C/ CFTFE ¹ , SC ² , ND ² V – 316L/316L, 316L/316L, ND ² D – Alloy C/TFE ¹ , Alloy C/Alloy C, ND ² E – Alloy C/Alloy C, 316L/316L, ND ² T – 316L/316L, 316L/PEEK, SC ³ G – Alloy C/Alloy C, Alloy C/PEEK, SC ³ P – ALA ⁴ / PEEK, ALA ⁴ / PEEK, SC ³ H – 316L/316L, 316L/316L, SC ³ J – Alloy C/Alloy C, Alloy C/Alloy C, SC ³ K – Alloy C/Alloy C, 316L/316L, SC ³	All All All All All 05, 12, 25 05, 12, 25 05, 12, 25 All All All All All All All All All

*Export restrictions apply to these sizes in these material choices.

**Comply with ATEX directive, see Section 3

CFTFE¹ = Carbon filled PTFE

SC² = Samarium Cobalt for pump size 02, 75,125 only; ND² = Neodymium for pump sizes 05, 12, 25 only

SC³ = Samarium Cobalt for all pump sizes

ALA⁴ = Alumina Ceramic

Adding an "N" to **Position 10** (not shown) is for Pump Wet End Only; **Position 7 Motor Mounting** must be selected for "N" Wet End Only pumps for correct mounting arrangement.

Consult factory for motor mounting arrangements not covered in the above chart.

20.1 KOPkit Part Number Identification - Metallic

Position	Code	Specifies	Options
1	KE	Model	KE – KOPkit Eclipse - Metallic
2 and 3	02, 05, 12, 25, 75, 125	Pump Size	02 – Max. Capacity .4 gpm (1.5 lpm) 05 – Max. Capacity 1.3 gpm (4.9 lpm) 12* – Max. Capacity 3.2 gpm(12.1 lpm) 25* – Max. Capacity 6.5 gpm (24.6 lpm) 75* – Max Capacity 20 gpm (75 lpm) 125* – Max Capacity 33 gpm (125 lpm)
4	X	Base Material	X – All base material types
5	L, B, T	Bearings	L – Carbon-92 B – Silicon Carbide T – Glass Filled Teflon
6	U, K	O-rings	U – PTFE K – Kalrez Grade 4079
7	LTE Includes Shaft/Gears, liner, O-rings	Drive Shaft/Gear, Idler Shaft/Gear Material	S-LTE – 316L/TFE ¹ , 316L/TFE ¹ F-LTE – 316L/316L, 316L/TFE ¹ B-LTE – ALA ⁴ / TFE ¹ , ALA ⁴ / TFE ¹ A-LTE – Alloy C/TFE ¹ , Alloy C/TFE ¹ C-LTE – Alloy C/Alloy C, Alloy C/TFE ¹ V-LTE – 316L/316L, 316L/316L D-LTE – Alloy C/TFE ¹ , Alloy C/Alloy C E-LTE – Alloy C/Alloy C, 316L/316L T-LTE – 316L/316L, 316L/PEEK G-LTE – Alloy C/Alloy C, Alloy C/PEEK P-LTE – ALA ⁴ / PEEK, ALA ⁴ / PEEK H-LTE – 316L/316L, 316L/316L J-LTE – Alloy C/Alloy C, Alloy C/Alloy C K-LTE – Alloy C/Alloy C, 316L/316L
7	STD Includes Shaft/Gears, liner, O-rings, Bearings	Drive Shaft/Gear, Idler Shaft/Gear Material	S-STD – 316L/TFE ¹ , 316L/TFE ¹ F-STD – 316L/316L, 316L/TFE ¹ B-STD – ALA ⁴ / TFE ¹ , ALA ⁴ / TFE ¹ A-STD – Alloy C/TFE ¹ , Alloy C/TFE ¹ C-STD – Alloy C/Alloy C, Alloy C/TFE ¹ V-STD – 316L/316L, 316L/316L D-STD – Alloy C/TFE ¹ , Alloy C/Alloy C E-STD – Alloy C/Alloy C, 316L/316L T-STD – 316L/316L, 316L/PEEK G-STD – Alloy C/Alloy C, Alloy C/PEEK P-STD – ALA ⁴ / PEEK, ALA ⁴ / PEEK H-STD – 316L/316L, 316L/316L J-STD – Alloy C/Alloy C, Alloy C/Alloy C K-STD – Alloy C/Alloy C, 316L/316L

*Export restrictions apply to these pump sizes depending on the material selection.

21. Parts Diagram and List, Eclipse 02 Metallic

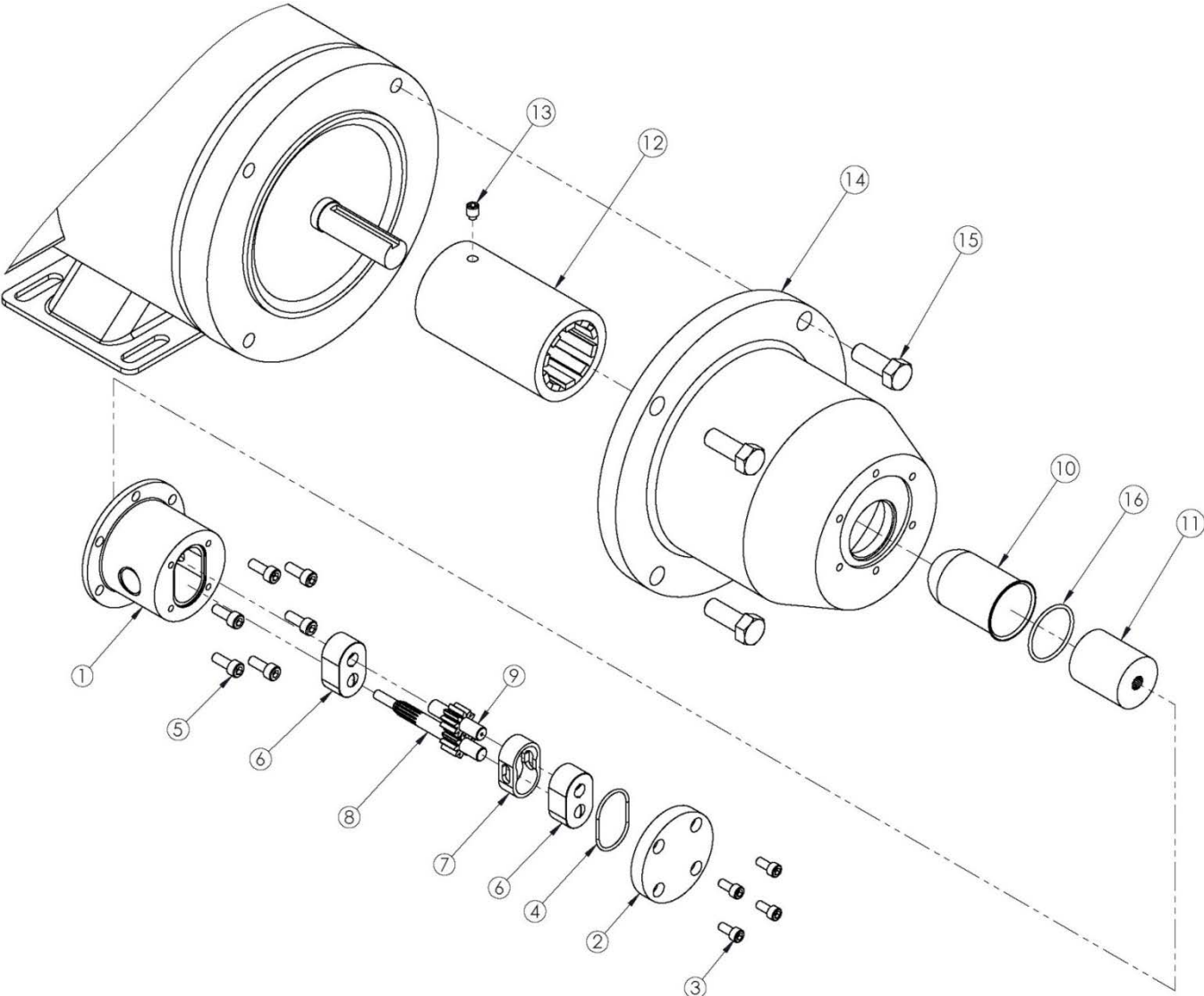

Eclipse Pump Series Size 02 Metallic Parts Diagram Key

Position 1,2,3,4 – Base Pump Material/Ports

Item	Description	Quantity
1	Housing, Center FNPT	1
	Housing, Center BSPT	1
2	Cover	1
3	Screw	4
7	Liner	1
10	Can, Containment	1
11	Driven Magnet Assembly	1
N/S	Nameplate	1
N/S	Drive Screw	2

Position 5 – Bearing Materials

Item	Description	Quantity
6	Bearing	2
	Bearing	2
	Bearing	2

Position 6 – O-ring Material Selection

Item	Description	Quantity
4	O-ring Cover	1
16	O-ring Containment Can	1

Position 9 – Gear Assembly Materials

Item	Description	Quantity
8	Gear Assembly, Drive	1
9	Gear Assembly, Idler	1

Position 7 – NEMA C-Face and IEC B3/14 Metric Frame Magnetic Coupling Arrangement

56C NEMA frame components

Item	Description	Quantity
5	Screw	6
12	Drive Magnet Assembly	1
13	Set Screw	1
14	Motor Adapter 56C	1
15	Bolt	4
Motor Mount Kit#	E02XXUF	

63 IEC B3/14 frame components

Item	Description	Quantity
5	Screw	6
12	Drive Magnet Assembly	1
13	Set Screw	1
14	Motor Adapter 63 IEC	1
15	Bolt	4
Motor Mount Kit#	E02XXUH	

71 IEC B3/14 frame components

Item	Description	Quantity
5	Screw	6
12	Drive Magnet Assembly	1
13	Set Screw	1
14	Motor Adapter 71 IEC	1
15	Bolt	4
Motor Mount Kit#	E02XXUJ	

KOPKit Suffix Selection Bill of Materials

Item	Description	Quantity
7	Liner, Housing	1
8	Gear Assembly, Drive	1
9	Gear Assembly, Idler	1
16	O-ring Cover	1

Item	Description	Quantity
6	Bearing	2
7	Liner, Housing	1
8	Gear Assembly, Drive	1
9	Gear Assembly, Idler	1
16	O-ring Cover	1

22. Parts Diagram and List, Eclipse 05 Metallic

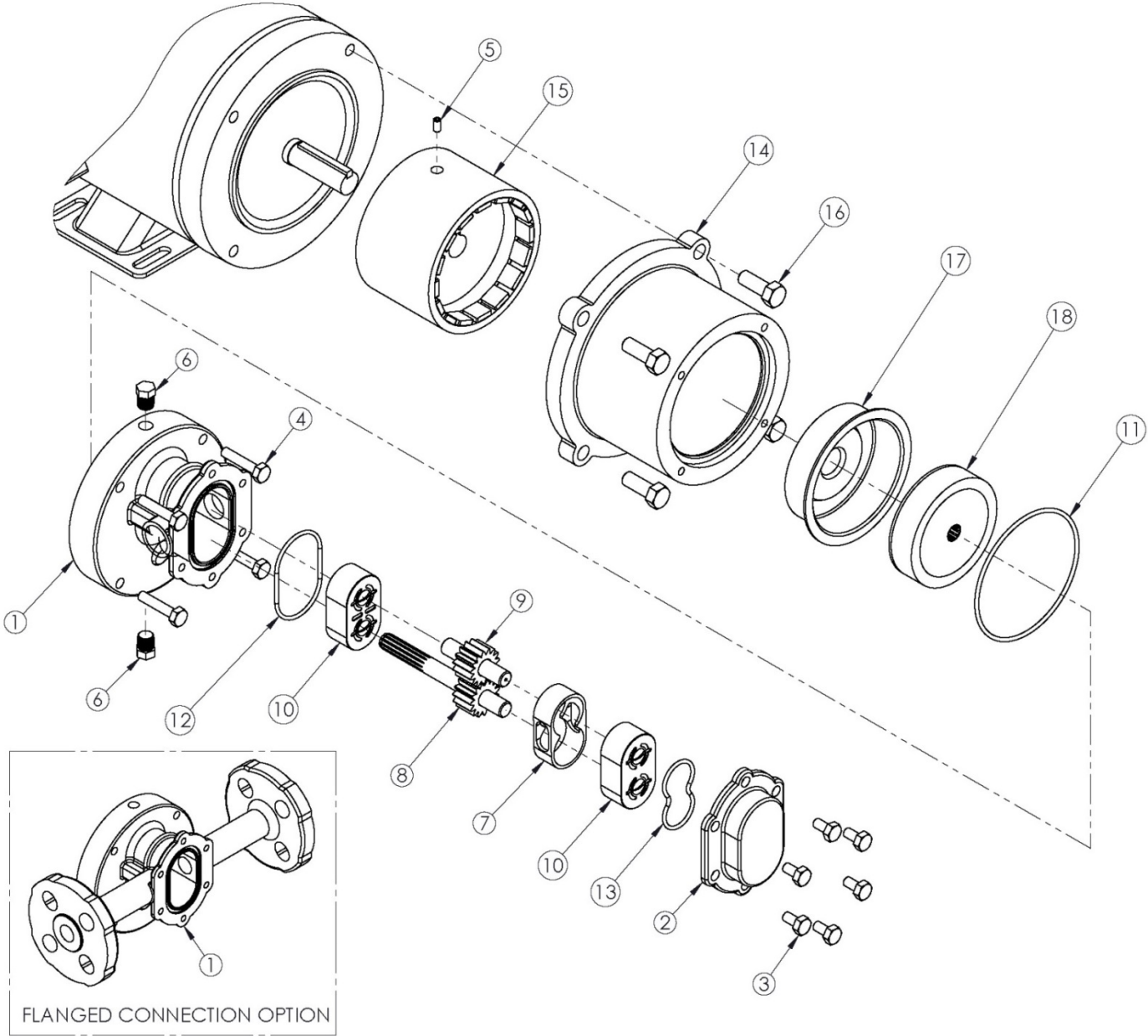

Eclipse Pump Series Size 05 Metallic Parts Diagram Key

Position 1,2,3,4 – Base Pump Material/Ports

Item	Description	Quantity
1	Housing, Center FNPT	1
	Housing, Center BSPT	1
	Housing, Center Flange	1
2	Cover, Front	1
3	Bolt	6
4	Screw	4
5	Set Screw	1
6	Plug, Drain	2
7	Liner, Housing	1
17	Can, Containment	1
18	Driven Magnet Assembly	1
N/S	Nameplate	1
N/S	Drive Screw	2

Position 5 - Bearing Materials

Item	Description	Quantity
10	Bearing	2
	Bearing	2
	Bearing	2

Position 6 - O-ring Material Selection

Item	Description	Quantity
11	O-ring Containment Can	1
12	O-ring Cover	1
13	O-ring Compression	1

Position 9 - Gear Assembly Materials

Item	Description	Quantity
8	Gear Assembly, Drive	1
9	Gear Assembly, Idler	1

Position 7 - NEMA C-Face and IEC B3/14 Metric Frame Magnetic Coupling Arrangement 56C NEMA frame components

Item	Description	Quantity
14	Casing	1
15	Drive Magnet Assembly	1
16	Bolt	4
Motor Mount Kit #	E05XXUF	

143-145TC NEMA frame components

Item	Description	Quantity
14	Casing	1
15	Drive Magnet Assembly	1
16	Bolt	4
Motor Mount Kit #	E05XXUO	

71 IEC B3/14 frame components

Item	Description	Quantity
14	Casing 71 IEC	1
15	Drive Magnet Assembly	1
16	Bolt	4
N/S	Motor Adapter 71 IEC	1
N/S	Bolt	4
Motor Mount Kit #	E05XXUJ	

80 IEC B3/14 frame components

Item	Description	Quantity
14	Casing 80 IEC	1
15	Drive Magnet Assembly	1
16	Bolt	4
N/S	Motor Adapter 80 IEC	1
N/S	Bolt	4
Motor Mount Kit #	E05XXUK	

KOPKit Suffix Selection Bill of Materials

Item	Description – LTE	Quantity
7	Liner, Housing	1
8	Gear Assembly, Drive	1
9	Gear Assembly, Idler	1
12	O-ring Cover	1

Item	Description – STD	Quantity
7	Liner, Housing	1
8	Gear Assembly, Drive	1
9	Gear Assembly, Idler	1
10	Bearing	1
12	O-ring Cover	1
13	O-ring Compression	1

23. Parts Diagram and List, Eclipse 12 Metallic

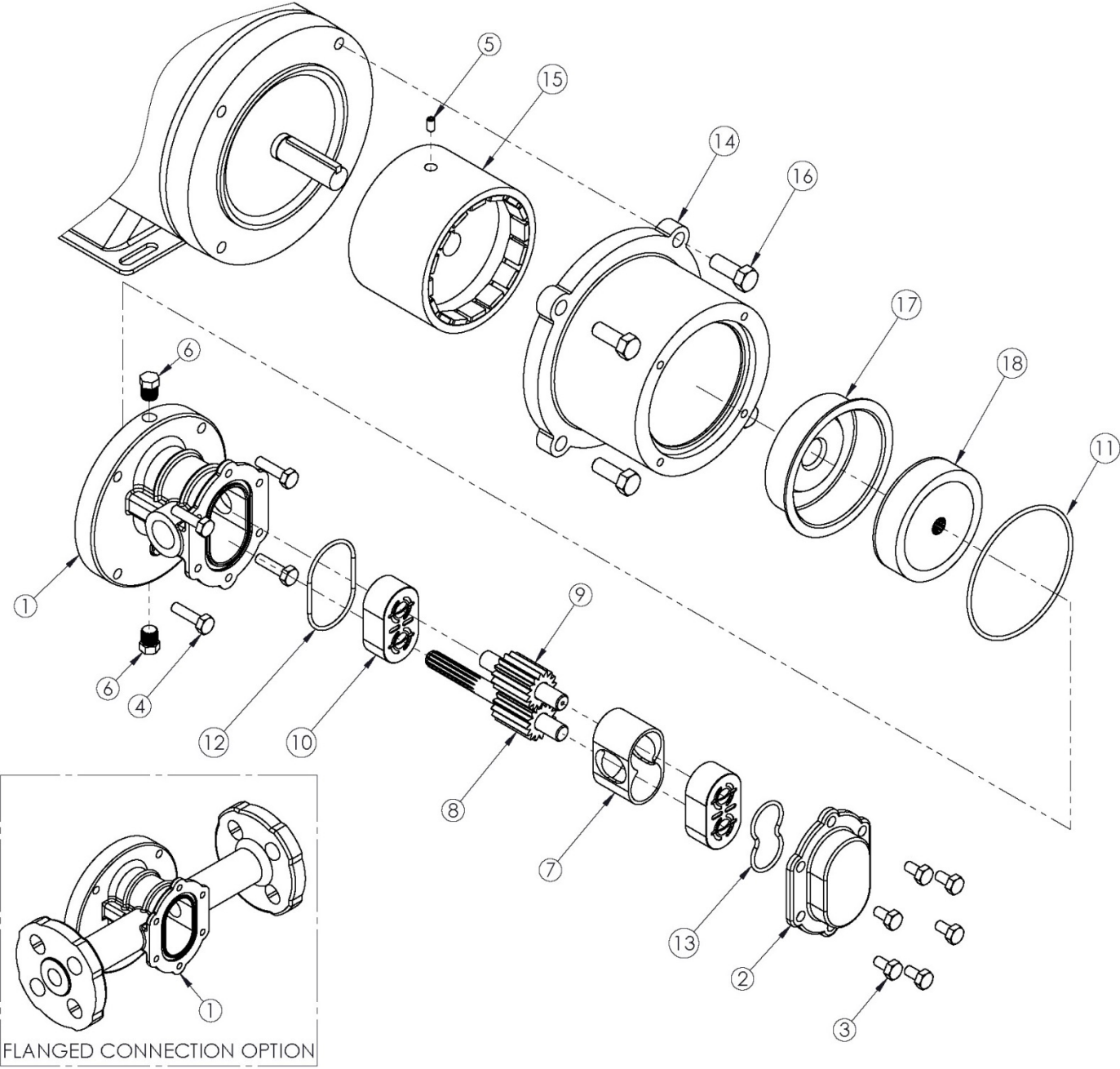

Eclipse Pump Series Size 12 Metallic Consolidated Bill of Material

Position 1,2,3,4 – Base Pump Material/Ports

Item	Description	Quantity
1	Housing, Center FNPT	1
	Housing, Center BSPT	
	Housing, Center Flange	
2	Cover, Front	1
3	Bolt	6
4	Screw	4
5	Set Screw	1
6	Plug, Drain	2
7	Liner, Housing	1
17	Can, Containment	1
18	Driven Magnet Assembly	1
N/S	Nameplate	1
N/S	Drive Screw	2

Position 5 - Bearing Materials

Item	Description	Quantity
10	Bearing	2
	Bearing	2
	Bearing	2

Position 6 - O-ring Material Selection

Item	Description	Quantity
11	O-ring Containment Can	1
12	O-ring Cover	1
13	O-ring Compression	1

Position 9 - Gear Assembly Materials

Item	Description	Quantity
8	Gear Assembly, Drive	1
9	Gear Assembly, Idler	1

56C NEMA frame components

Item	Description	Quantity
14	Casing, 56-143/5TC	1
15	Drive Magnet Assembly	1
16	Bolt	4
Motor Mount Kit #	E12XXUF	

Position 7 – NEMA C-Face and IEC B3/14 Metric Frame Magnetic Coupling Arrangement 143-145TC NEMA frame components

Item	Description	Quantity
14	Casing, 56-143/5TC	1
15	Drive Magnet Assembly	1
16	Bolt	4
Motor Mount Kit #	E12XXUO	

71 IEC B3/14 frame components

Item	Description	Qty
14	Casing 71 IEC	1
15	Drive Magnet Assembly	1
16	Bolt	4
N/S	Motor Adapter 71 IEC	1
N/S	Bolt	4
Motor Mount Kit #	E12XXUJ	

80 IEC B3/14 frame components

Item	Description	Qty
14	Casing 80 IEC	1
15	Drive Magnet Assembly	1
16	Bolt	4
N/S	Motor Adapter 80 IEC	1
N/S	Bolt	4
Motor Mount Kit #	E12XXUK	

KOPKit Suffix Selection Bill of Materials

Item	Description	Qty
7	Liner, Housing	1
8	Gear Assembly, Drive	1
9	Gear Assembly, Idler	1
12	O-ring Cover	1

Item	Description	Qty
7	Liner, Housing	1
8	Gear Assembly, Drive	1
9	Gear Assembly, Idler	1
10	Bearing	1
12	O-ring Cover	1
13	O-ring Compression	1

24. Parts Diagram and List, Eclipse 25 Metallic

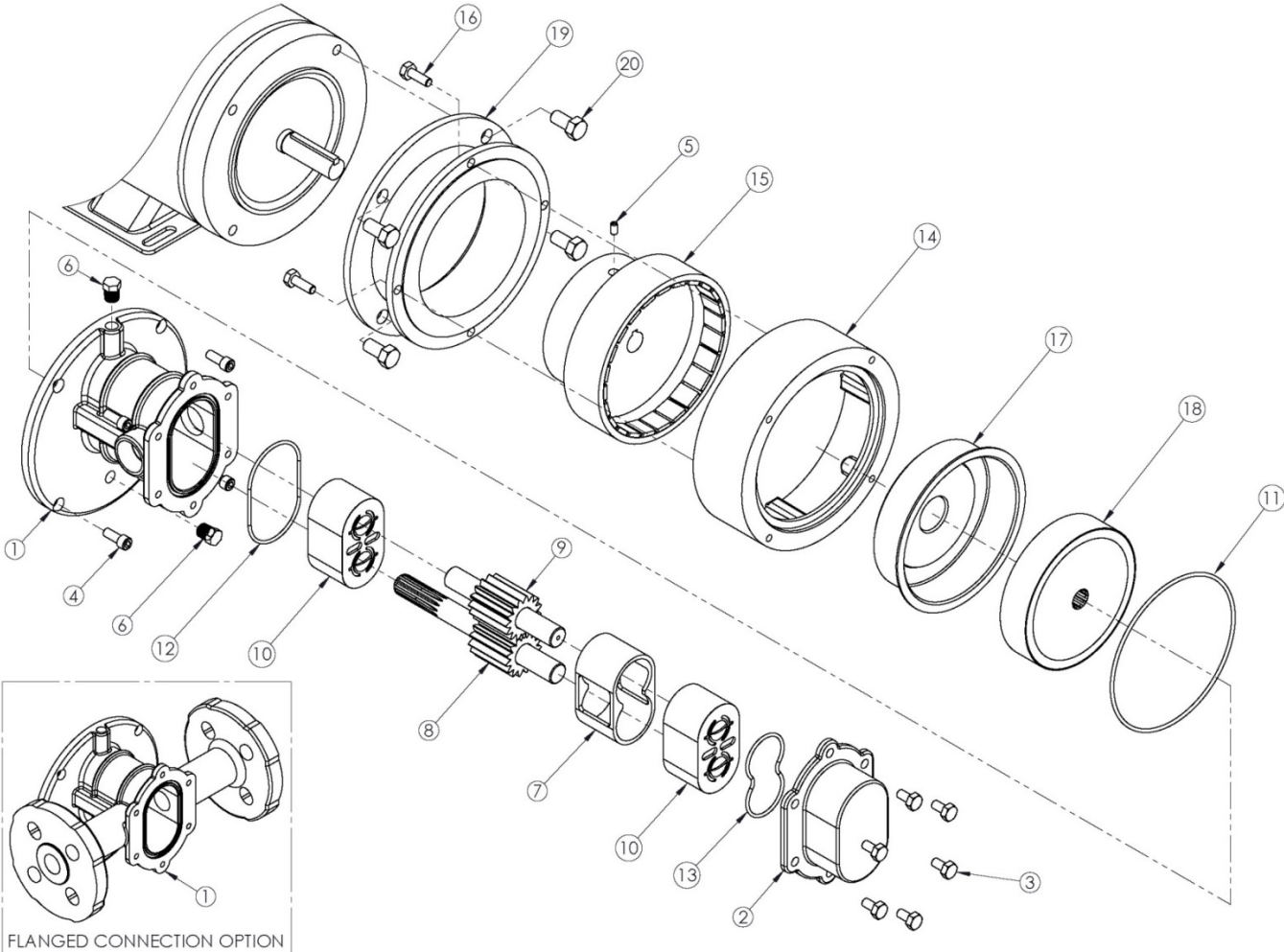

Eclipse Pump Series Size 25 Metallic Parts Diagram Key

Position 1,2,3,4 - Base Pump Material/Ports

Item	Description	Quantity
1	Housing, Center FNPT	1
	Housing, Center BSPT	
	Housing, Center Flange	
2	Cover, Front	1
3	Bolt	6
4	Screw	4
5	Set Screw	1
6	Plug, Drain	2
7	Liner, Housing	1
17	Can, Containment	1
18	Driven Magnet Assembly	1

Position 5 - Bearing Materials

Item	Description	Qty
10	Bearing	2
	Bearing	
	Bearing	

Position 6 - O-ring Material Selection

Item	Description	Quantity
11	O-ring Containment Can	1
12	O-ring Cover	1
13	O-ring Compression	1

Position 9 - Gear Assembly Materials

Item	Description	Quantity
8	Gear Assembly, Drive	1
9	Gear Assembly, Idler	1

Position 7 - NEMA C-Face and IEC B3/14 Metric Frame Magnetic Coupling Arrangement 56C NEMA frame components

Item	Description	Quantity
14	Casing	1
15	Drive Magnet Assembly	1
16	Bolt	4
19	Spool 56C/143-5TC	1
20	Bolt	4
Motor Mount Kit #	E25XXUF	

143-145TC NEMA frame components

Item	Description	Quantity
14	Casing	1
15	Drive Magnet Assembly	1
16	Bolt	1
19	Spool 56C/143-5TC	1
20	Bolt	4
Motor Mount Kit #	E25XXUO	

80 IEC B34 frame components

Item	Description	Quantity
14	Casing	1
15	Drive Magnet Assembly	1
16	Bolt	4
19	Spool 56C/143-5TC	1
20	Bolt	4
Motor Mount Kit #	E25XXUK	

90 IEC B34 frame components

Item	Description	Quantity
14	Casing	1
15	Drive Magnet Assembly	1
16	Bolt	4
19	Spool 56C/143-5TC	1
20	Bolt	4
Motor Mount Kit #	E25XXUL	

KOPKit Suffix Selection Bill of Materials

Item	Description – LTE	Quantity
7	Liner, Housing	1
8	Gear Assembly, Drive	1
9	Gear Assembly, Idler	1
12	O-ring Cover	1

Item	Description – STD	Quantity
7	Liner, Housing	1
8	Gear Assembly, Drive	1
9	Gear Assembly, Idler	1
10	Bearing	2
12	O-ring Cover	1
13	O-ring Compression	1

25. Parts Diagram and List, Eclipse 75 Metallic

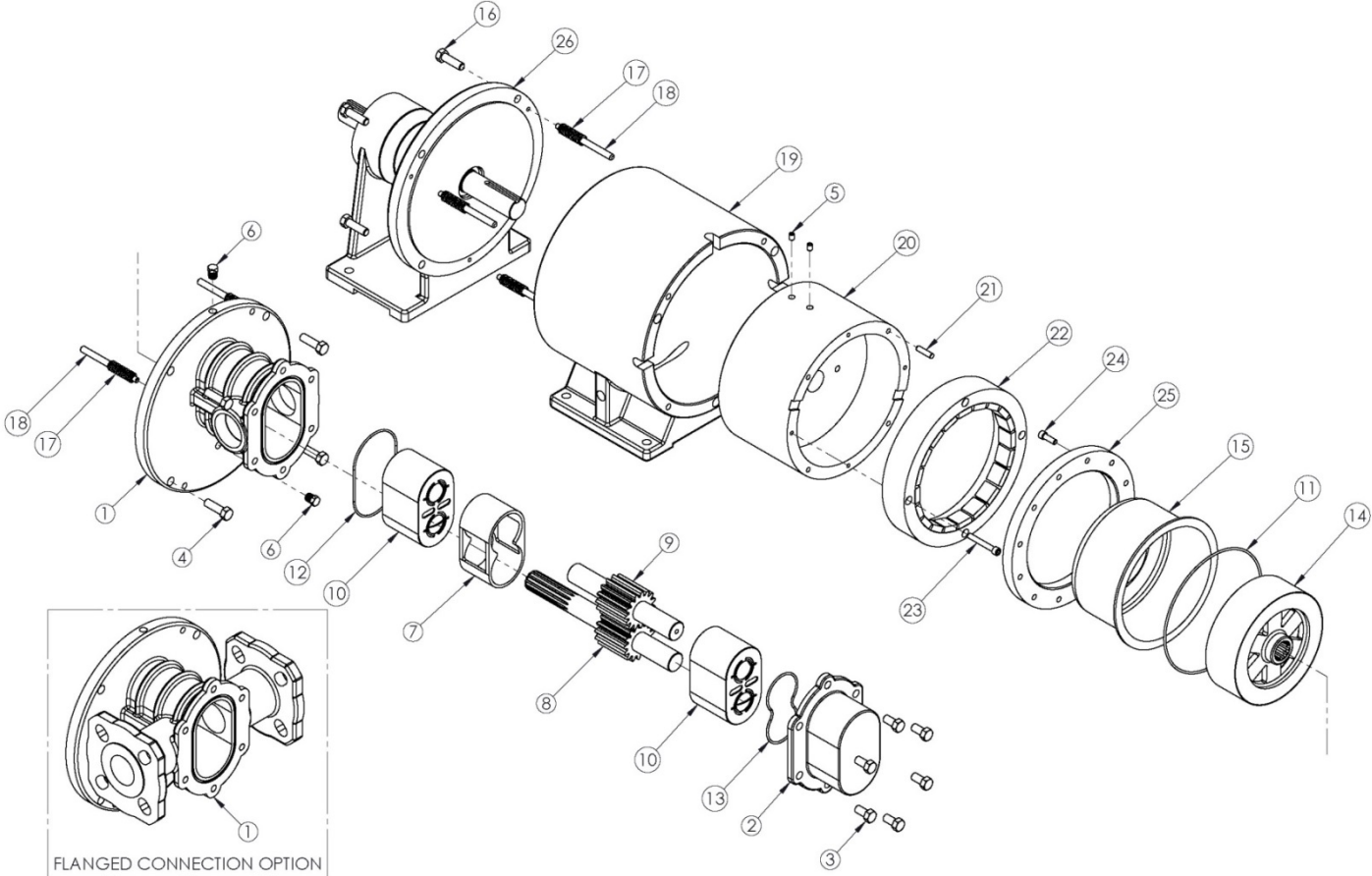

Eclipse Metallic 75/125 Power frames are shipped without oil. Use Standard motor oil: SAE 10W-30, 10W-40, or 5W-30.

Eclipse Pump Series Size 75 Metallic Parts Diagram Key

Position 1,2,3,4 - Base Pump Material/Ports

Item	Description	Quantity
1	Housing, Center FNPT	1
	Housing, Center BSPT	
	Housing, Center Flange	
2	Cover, Front	1
3	Bolt, Front Cover	6
4	Bolt, Housing	4
5	Set Screw	2
6	Plug, Drain	2
7	Liner	1
14	Driven Magnet Assembly	1
15	Can, Containment	1
17	Spring	6
18	Pin, Guide	6
19	Power Frame Adapter	1
25	Ring, Containment Can	1
26	Bolt, Containment Ring	12
N/S	Nameplate	1
N/S	Drive Screw	2
N/S	Eyebolt	1

Position 5 - Bearing Materials

Item	Description	Quantity
10	Bearing	2
	Bearing	2
	Bearing	2

Position 6 - O-ring Material Selection

Item	Description	Quantity
11	O-ring Containment Can	1
12	O-ring Cover	1
13	O-ring Compression	1

Position 7 - NEMA and IEC Metric Frame Magnetic Coupling Arrangement NEMA frame components (182-184T or 213-215) 1.125in shaft diameter

Item	Description	Quantity
16	Bolt, Power Frame	4
20	Housing, Drive Magnet	1
21	Pin, Drive Magnet/Holder	4
22	Drive Magnet Ring	1
23	Screw, Magnet/Holder	4
26	Power Frame Assembly	1
Motor Mount Kit #	E75XXUR	

IEC Metric frame components (100/112) 28mm shaft diameter

Item	Description	Quantity
16	Bolt, Power Frame	4
20	Housing, Drive Magnet	1
21	Pin, Drive Magnet/Holder	4
22	Drive Magnet Ring	1
23	Screw, Magnet/Holder	4
26	Power Frame Assembly	1
Motor Mount Kit #	E75XXUU	

Position 9 - Gear Assembly Materials

Item	Description	Quantity
8	Gear Assembly, Drive	1
9	Gear Assembly, Idler	1

KOPKit Suffix Selection Bill of Materials

Item	Description – LTE	Quantity
7	Liner, Housing	1
8	Gear Assembly, Drive	1
9	Gear Assembly, Idler	1
12	O-ring Cover	1

Item	Description – STD	Quantity
7	Liner, Housing	1
8	Gear Assembly, Drive	1
9	Gear Assembly, Idler	1
10	Bearing	2
12	O-ring Cover	1
13	O-ring Cover	1

26. Parts Diagram and List, Eclipse 125 Metallic

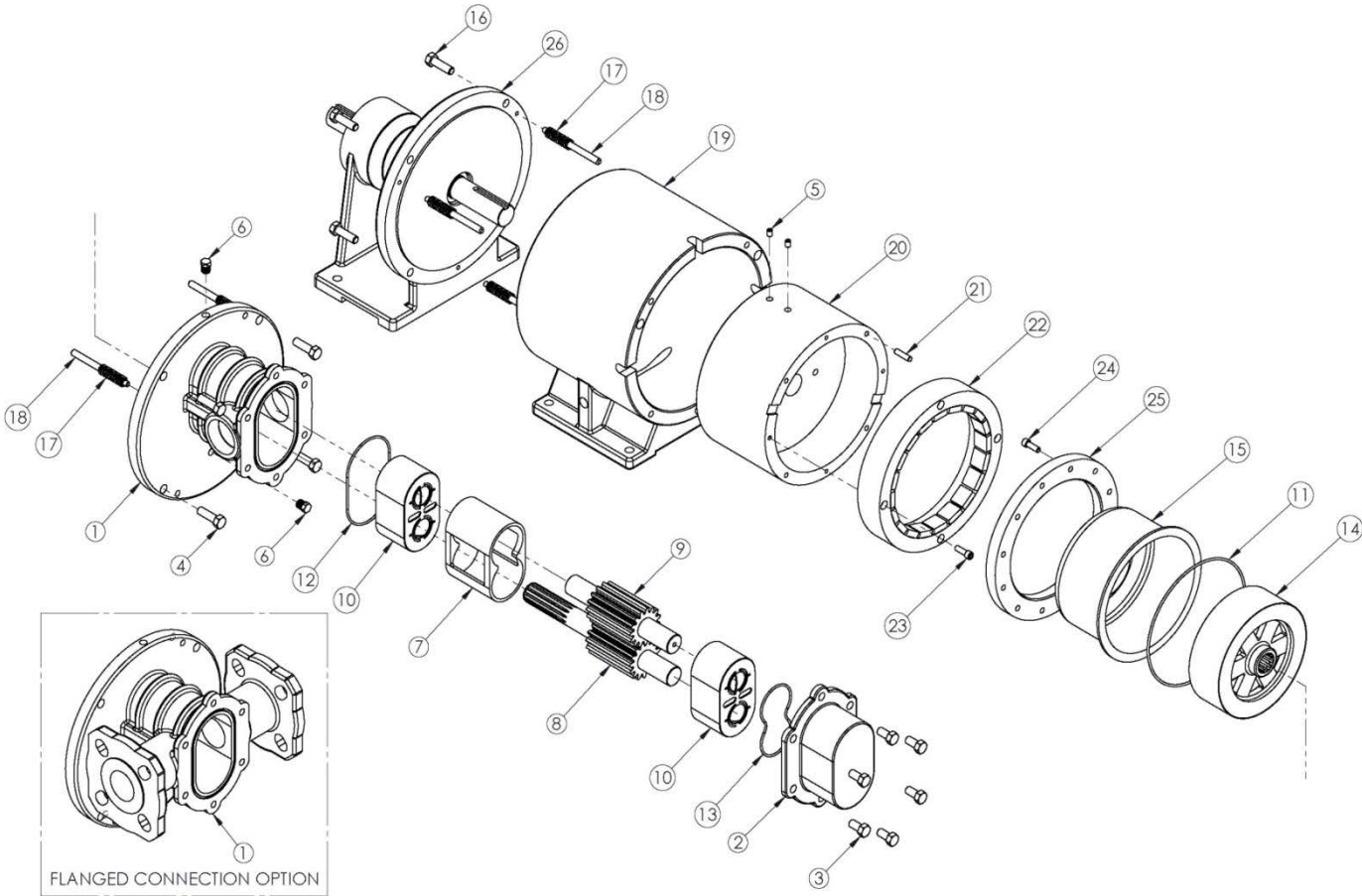

**Eclipse Metallic 75/125 Power frames are shipped without oil.
Use Standard motor oil: SAE 10W-30, 10W-40, or 5W-30.**

Eclipse Pump Series Size 125 Metallic Consolidated Bill of Material

Position 1,2,3,4 - Base Pump Material/Ports

Item	Description	Quantity
1	Housing, Center FNPT	1
	Housing, Center BSPT	
	Housing, Center Flange	
2	Cover, Front Brg Flush	1
3	Bolt, Front Cover	6
4	Bolt, Housing	4
5	Set Screw	2
6	Plug, Drain	2
7	Liner	1
14	Driven Magnet Assembly	1
15	Can, Containment	1
17	Spring	6
18	Pin, Guide	6
19	Power Frame Adapter	1
25	Ring, Containment Can	1
26	Bolt, Containment Ring	12
N/S	Nameplate	1
N/S	Drive Screw	2
N/S	Eyebolt	1

Position 5 - Bearing Materials

Item	Description	Quantity
10	Bearing	2
	Bearing	2
	Bearing	2

Position 6 - O-ring Material Selection

Item	Description	Quantity
11	O-ring Containment Can	1
12	O-ring Cover	1
13	O-ring Compression	1

Position 7 - NEMA and IEC Metric Frame Magnetic Coupling Arrangement NEMA frame components (182-184T or 213-215) 1.125in shaft diameter

Item	Description	Quantity
16	Bolt, Power Frame	4
20	Housing, Drive Magnet	1
21	Pin, Drive Magnet/Holder	4
22	Drive Magnet Ring	1
23	Screw, Magnet/Holder	4
26	Power Frame Assembly	1
Motor Mount Kit #	E125XXUR	

IEC Metric frame components (100/112) 28mm shaft diameter

Item	Description	Quantity
16	Bolt, Power Frame	4
20	Housing, Drive Magnet	1
21	Pin, Drive Magnet/Holder	4
22	Drive Magnet Ring	1
23	Screw, Magnet/Holder	4
26	Power Frame Assembly	1
Motor Mount Kit #	E125XXUU	

Position 9 - Gear Assembly Materials

Item	Description	Quantity
8	Gear Assembly, Drive	1
9	Gear Assembly, Idler	1

KOPKit Suffix Selection Bill of Materials

Item	Description – LTE	Quantity
7	Liner, Housing	1
8	Gear Assembly, Drive	1
9	Gear Assembly, Idler	1
12	O-ring Cover	1

Item	Description –STD	Quantity
7	Liner, Housing	1
8	Gear Assembly, Drive	1
9	Gear Assembly, Idler	1
10	Bearing	2
12	O-ring Cover	1
13	O-ring Cover	1

27. Inspection and Wear Limits

Inspect internal pump components as follows. See **Chart 27.1 for Service and Replacement Limits**.

Bearings

Inspect both bearing bores and end surfaces for wear and scoring. If wear or scoring is present on the end surface of the bearing, the bearing can be flipped to expose the undamaged face to the gear side. Bearings should be replaced when both ends show wear and/or scoring or when the bores have reached the replacement limit.

Shafts

Both the idler and the drive shaft should be inspected carefully for scoring, wear, and any signs of cracking or chips in the shaft surface. No cracks or chips are allowed. Shafts should be replaced if they show signs of cracks or chips anywhere on the surface, if they are deeply scored, or if they have reached their replacement limit.

Gears

Gears can be measured for dimensional change to their length and outside diameter. Gear teeth should also be visually inspected for wear and damage. Gear teeth can be damaged due to solids moving through the pump, which will affect only some teeth, or excessive pressure, which will distort the outside tips of all teeth. Gears that have reached their replacement limits or show signs of physical damage or distortion should be replaced. Backlash can be checked by temporarily inserting the two gear/shaft assemblies into known good bearings and observing gear tooth mesh and backlash.

Housing Liner

The housing liner should be visually inspected for scoring, wear, and steps on the inner diameter of the two gear bores. See chart for specific limits.



The viscosity of the pumped product will affect the service limits of your Eclipse pump. Fluids with higher viscosities will usually be more tolerant of wear and allow longer maintenance intervals. Fluids with low viscosities will usually require more frequent maintenance, as they are less tolerant of clearances between the pump's internal surfaces. Regular inspection and detailed maintenance records will determine the optimal maintenance interval for each application.

Maximum Flange Loads – Non-metallic		
Pump Size	Flange Loads lb (N)	Flange Loads ft-lb (N m)
Eclipse 02	25 (111)	10 (13.5)
Eclipse 05	25 (111)	20 (27)
Eclipse 12	25 (111)	25 (33)
Eclipse 25	30 (133)	20 (27)
Eclipse 75 & 125	50 (222)	25 (34)

Maximum Flange Loads – Metallic		
Pump Size	Flange Loads lb (N)	Flange Loads ft-lb (N m)
Eclipse 02	25 (111)	10 (13.5)
Eclipse 05	25 (111)	20 (27)
Eclipse 12	30 (111)	30 (33)
Eclipse 25	40 (133)	30 (27)
Eclipse 75 & 125	65 (222)	35 (34)

27.1 Service and Replacement Limits

Part	Pump Model	New Spec Dimension	Serviceable Limit	Replacement Limit
Bearings	E02	ID 0.293" Length 0.499"	0.0025 bore wear end wear – flip over	0.005 bore wear both ends worn
	E05/E12	ID 0.439"	0.003 bore wear end wear – flip over	0.006 bore wear both ends worn
	E25	ID 0.627"	0.004 bore wear end wear – flip over	0.008 bore wear both ends worn
	E75/E125	ID 1.002"	0.005 bore wear end wear – flip over	0.010 bore wear both ends worn
Shafts	E02	OD 0.2916"	0.001 smooth wear	0.001 deep or rough scoring
	E05/E12	OD 0.437"		
	E25	OD 0.625"		
	E75/E125	OD 1.000"		
NOTE: Cracks or chips in shaft surface are not allowed				
Gears	E02	Length 0.4055"	0.0005 wear – length	0.001 wear – length
		OD 0.600"	0.003 wear – OD 0.010 Backlash	0.006 wear – OD 0.020 Backlash
	E05	Length 0.624"	0.001 wear – length	0.002 wear – length
		OD 1.063"	0.004 wear – OD 0.015 Backlash	0.008 wear – OD 0.030 Backlash
	E12	Length 1.249" OD 1.063"	Same as E05/EH05 above	Same as E05/EH05 above
	E25	Length 1.499"	0.002 wear – length	0.004 wear – length
OD 1.417"		0.005 wear – OD 0.020 Backlash	0.010 wear – OD 0.040 Backlash	
E75	Length 1.998"	0.003 wear – length 0.006 wear – OD	0.006 wear – length 0.012 wear – OD	
	OD 2.125"			
E125	Length 2.998" OD 2.125"	0.025 Backlash	0.050 Backlash	
Housing Liner	E02	n/a	0.002 wear or step	0.004 wear or step
	E05/E12	n/a	0.003 wear or step	0.006 wear or step
	E25	n/a	0.004 wear or step	0.008 wear or step
	E75/E125	n/a	0.005 wear or step	0.100 wear or step

28. Troubleshooting

Symptom	Probable Cause	Remedy
No Liquid Delivered	Pump not primed.	Prime pump. Ensure suction piping and any strainers are clean and clear of any obstructions.
	Motor incorrectly wired.	Check wiring diagram.
	Air leak in suction.	Locate and repair leak.
	Rotation direction incorrect.	Reverse motor wiring.
	Suction and/or discharge valves closed.	Open valves.
	Suction lift too high.	Do not exceed published limits.
	Magnetic coupling decoupled.	Stop motor, eliminate blockage or jamming and restart. If no blockage exists verify that operating conditions do not exceed capabilities of the pump.
Drive magnet interference.	Adjust the drive magnet location on the motor shaft to not interfere with the casing/spool.	
Low Liquid Delivery	Discharge head higher than calculated.	Reduce discharge restrictions e.g.: Open throttle valve or back-pressure valve.
	Air leak in suction.	Locate and repair leak.
	Rotational speed incorrect.	Check speed and wiring. Adjust as required.
	Suction pipe restrictions	Ensure suction valve is fully open and strainer is clean.
	Pressure relief valve open	Reset PRV to proper setting based on system pressure.
	Pump components worn.	Inspect and repair as required, see KOPkit details.
Low Discharge Pressure	Rotational speed incorrect.	Check speed and adjust as required.
	Air leak in suction.	Repair leak.
	Air or gas in liquid.	Eliminate air or gas that can be caused by obstructions in suction piping, leak in suction pipe, or cavitation and/or boiling of pumped fluid.
	Pump components worn	Inspect and repair as required, see KOPkit details.
Pump Gradually Loses Prime	Air pocket in suction line.	Eliminate pocket.
	Air entering suction line.	Keep suction inlet submerged at all times.
Pump Noisy	Pump worn or damaged.	Inspect and repair as required, see KOPkit details.
	Air or gas in liquid.	Eliminate air or gas. Check system piping for locations that may trap air or gas.
	Fasteners not properly torqued.	Inspect parts for damage. Re-install to proper torque in progressive "crisscross" pattern.
	Drive magnet interference.	Adjust the drive magnet location on the motor shaft to not interfere with the casing/spool.

Pump Runs Hot	Excessive loading on the pump. Driven magnet installed backwards.	Reevaluate pump application. Check system monitoring devices are set properly. Replace driven magnet and install in correct orientation.
Symptom	Probable Cause	Remedy
Motor Runs Hot or Overloads	It is normal for motors to feel hot even when not overloaded. Motor wired incorrectly. Voltage or frequency low. Motor not sized correctly. Heavy or viscous liquid being pumped. Binding internal pump parts.	Check the actual temperature of the motor housing with suitable instrumentation. Verify the figures with the motor manufacturer. Check wiring diagram. Correct condition. Higher pressures may require more power than the motor is capable. Consult performance curves. Pumping fluids heavier or more viscous than water requires a properly sized, higher powered motors. Inspect and correct condition.

29. Specifications

Eclipse 02 General Specifications	Non-Metallic	Metallic
Port Size and Type	¼" FNPT or BSPT	¼" FNPT or BSPT
Direction of Rotation	Bi-directional	Bi-directional
Maximum Differential Pressure	150 psig (10 bar, 1034 kPa)	150 psig (10 bar, 1034 kPa)
Maximum Allowable Working Pressure	200 psig (13.8 bar, 1379 kPa)	200 psig (13.8 bar, 1379 kPa)
Maximum Speed	1750 rpm	1750 rpm
Maximum Capacity at 0 psig	0.4 US gpm (1.5 lpm)	0.4 US gpm (1.5 lpm)
Maximum Viscosity	1,000 cps	1,000 cps
Maximum Process Fluid Temperature	150 F (66 C) at maximum differential pressure	150 F (66 C) at maximum differential pressure
Minimum Process Fluid Temperature	-40 F (-40 C)	-40 F (-40 C)
Fluid pH Range	0-14	0-14
Gear Type	Compact Spur Gear Design	Compact Spur Gear Design
Bearing Type	Sleeve Bearing Integral Wear Plate	Sleeve Bearing Integral Wear Plate
Bearing Material	Carbon or Silicon Carbide	Carbon, Silicon Carbide or PTFE
Magnetic Torque Rating	22 in-lbs. (2.5 N-m)	Consult Factory
Motor Frame Sizes - NEMA	56C and 143/145TC	56C
Motor Frame Sizes - IEC	63, 71, 80 B3/B14 Face	63 and 71 B3/B14 Face
Pump Housing Materials of Construction	Carbon Filled Modified PTFE	316L SS or Alloy C
Gear Materials of Construction	Modified PTFE	316L SS, Alloy C, Modified PTFE, or PEEK
Shaft Materials of Construction	Alumina Ceramic	316L SS, Alloy C, or Alumina Ceramic
Can Materials of Construction	Kynar	316L SS or Alloy C
Magnet Materials of Construction	Neodymium Iron	Neodymium Iron
O-ring Seal Materials	Viton A, EPDM, or Kalrez	PTFE and Kalrez
Approximate Weight	3.6 lbs. (1.6 kg) less motor	Consult Factory

Eclipse 05 General Specifications	Non-Metallic	Metallic
Port Size and Type	3/8" FNPT or BSPT	½" FNPT or BSPT, ½" ANSI 150# / DIN 10/15 Flange
Direction of Rotation	Bi-directional	Bi-directional
Maximum Differential Pressure	150 psig (10 bar, 1034 kPa)	150 psig (10 bar, 1034 kPa)
Maximum Allowable Working Pressure	200 psi (13.8 bar, 1379 kPa)	200 psi (13.8 bar, 1379 kPa)
Maximum Speed	1750 rpm	1750 rpm
Maximum Capacity at 0 psig	1.7 US gpm (6.3 lpm)	1.7 US gpm (6.3 lpm)
Maximum Viscosity	10,000 cps	10,000 cps
Maximum Process Fluid Temperature	150 F (66 C) at maximum differential pressure	150 F (66 C) at maximum differential pressure
Minimum Process Fluid Temperature	-40 F (-40 C)	-40 F (-40 C)
Fluid pH Range	0-14	0-14
Gear Type	Compact Spur Gear Design	Compact Spur Gear Design
Bearing Type	Sleeve Bearing Integral Wear Plate	Sleeve Bearing Integral Wear Plate
Bearing Material	Carbon or Silicone Carbide	Carbon, Silicone or PTFE
Magnetic Torque Rating	228 in-lbs. (25 N-m)	Consult factory
Motor Frame Sizes – NEMA	56C, 143/145TC, 182C/184C	56C and 143/145TC
Motor Frame Sizes – IEC	63 and 80 B3/B14 Face	71 and 80 B3/B14 Face

Pump Housing Materials of Construction	Kynar	316L SS or Alloy C
Gear Materials of Construction	Modified PTFE	316L SS, Alloy C, Modified PTFE, or PEEK
Shaft Materials of Construction	Alumina Ceramic	316L SS, Alloy C, or Alumina Ceramic
Can Materials of Construction	Kynar	316L SS or Alloy C
Magnet Materials of Construction	Neodymium Iron	Neodymium Iron
O-ring Seal Materials	Viton A, EPDM, or Kalrez	PTFE and Kalrez
Approximate Weight	8.9 lbs. (4.0 kg) less motor	Consult Factory

29.3 Eclipse 12 General Specifications	Non-Metallic	Metallic
Port Size and Type	¾" FNPT or BSPT	½" FNPT or BSPT, ½" ANSI 150# / DIN 10/15 Flange
Direction of Rotation	Bi-directional	Bi-directional
Maximum Differential Pressure	150 psig (10 bar, 1034 kPa)	150 psig (10 bar, 1034 kPa)
Maximum Allowable Working Pressure	200 psi (13.8 bar, 1379 kPa)	200 psi (13.8 bar, 1379 kPa)
Maximum Speed	1750 rpm	1750 rpm
Maximum Capacity at 0 psig	3.4 US gpm (12.9 lpm)	3.4 US gpm (12.9 lpm)
Maximum Viscosity	10,000 cps	10,000 cps
Maximum Process Fluid Temperature	150 F (66 C) at maximum differential pressure	150 F (66 C) at maximum differential pressure
Minimum Process Fluid Temperature	-40 F (-40 C)	-40 F (-40 C)
Fluid pH Range	0-14	0-14
Gear Type	Compact Spur Gear Design	Compact Spur Gear Design
Bearing Type	Sleeve Bearing Integral Wear Plate	Sleeve Bearing Integral Wear Plate
Bearing Material	Carbon or Silicon Carbide	Carbon, Silicon Carbide, or PFTE
Magnetic Torque Rating	228 in-lbs. (25.7 N-m)	Consult Factory
Motor Frame Sizes - NEMA	56C, 143/145TC, 182C/184C	56C and 143/145TC
Motor Frame Sizes – IEC	63, 71, 80 B3/B14 Face	71 and 80 B3/B14 Face
Pump Housing Materials of Construction	Kynar	316L SS or Alloy C
Gear Materials of Construction	Modified PTFE	316L SS, Alloy C, Modified PTFE, or PEEK
Shaft Materials of Construction	Alumina Ceramic	316L SS, Alloy C, or Alumina Ceramic
Can Materials of Construction	Kynar	316L SS or Alloy C
Magnet Materials of Construction	Neodymium Iron	Neodymium Iron
O-ring Seal Materials	Viton A, EPDM, or Kalrez	PTFE and Kalrez
Approximate Weight	10.0 lbs. (4.5 kg) less motor	Consult Factory

Eclipse 25 General Specifications	Non-Metallic	Metallic
Port Size and Type	1" ANSI 150# / DIN 20/25 Flanged	¾" NPT or BSPT, ¾" ANSI 150# / DIN 10/15 Flange
Direction of Rotation	Bi-directional	Bi-directional
Maximum Differential Pressure	150 psig (10 bar, 1034 kPa)	150 psig (10 bar, 1034 kPa)
Maximum Allowable Working Pressure	200 psi (13.8 bar, 1379 kPa)	200 psi (13.8 bar, 1379 kPa)
Maximum Speed	1750 rpm	1750 rpm
Maximum Capacity at 0 psig	7.4 US gpm (28.0 lpm)	7.4 US gpm (28.0 lpm)
Maximum Viscosity	10,000 cps	10,000 cps
Maximum Process Fluid Temperature	150 F (66 C) at maximum differential pressure	150 F (66 C) at maximum differential pressure
Minimum Process Fluid Temperature	-40 F (-40 C)	-40 F (-40 C)

Fluid pH Range	0-14	0-14
Gear Type	Compact Spur Gear Design	Compact Spur Gear Design
Bearing Type	Sleeve Bearing Integral Wear Plate	Sleeve Bearing Integral Wear Plate
Bearing Material	Carbon or Silicon Carbide	Carbon, Silicon Carbide, or PTFE
Magnetic Torque Rating	474 in-lbs. (53.5 N-m)	Consult Factory
Motor Frame Sizes - NEMA	56C, 143/145TC, 182C/184C	56C and 143/145TC
Motor Frame Sizes - IEC	100/112 B3/B14 Face	80 and 90 B3/B14 Face
Pump Housing Materials of Construction	Kynar	316L SS or Alloy C
Gear Materials of Construction	Modified PTFE	316L SS, Alloy C, Modified PTFE, or PEEK
Shaft Materials of Construction	Alumina Ceramic	316L SS, Alloy C, or Alumina Ceramic
Can Materials of Construction	Kynar	316L SS or Alloy C
Inner Magnet Materials of Construction	Neodymium Iron	Neodymium Iron
O-ring Seal Materials	Viton A, EPDM, or Kalrez	PTFE and Kalrez
Approximate Weight	26.0 lbs. (11.8 kg) less motor	Consult Factory

Eclipse 75 General Specifications	Non-Metallic	Metallic
Port Size and Type	1½" ANSI 150# / DIN 32/40 Flanged	1½" NPT or BSPT, 1½" ANSI 150# / DIN 32/40 Flange
Direction of Rotation	Bi-directional	Bi-directional
Theoretical Displacement	1.423 US gal / 100 rev. (53.9 cc / rev.)	1.423 US gal / 100 rev. (53.9 cc / rev.)
Maximum Differential Pressure	150 psig (10 bar, 1034 kPa)	150 psig (10 bar, 1034 kPa)
Maximum Allowable Working Pressure	200 psi (13.8 bar, 1379 kPa)	200 psi (13.8 bar, 1379 kPa)
Maximum Speed	1750 rpm	1750 rpm
Maximum Capacity at 0 psig	22 US gpm (83.3 lpm)	22 US gpm (83.3 lpm)
Maximum Viscosity	10,000 cps	10,000 cps
Maximum Process Fluid Temperature	150 F (66 C) at maximum 125 psi differential pressure	150 F (66 C) at maximum 125 psi differential pressure
Minimum Process Fluid Temperature	-40 F (-40 C)	-40 F (-40 C)
Fluid pH Range	0-14	0-14
Gear Type	Compact Spur Gear Design	Compact Spur Gear Design
Bearing Type	Sleeve Bearing Integral Wear Plate	Sleeve Bearing Integral Wear Plate
Bearing Material	Carbon or Silicon Carbide	Carbon, Silicon Carbide, or PTFE
Magnetic Torque Rating	668 in-lbs. (75.4 N-m)	Consult Factory
Motor Frame Sizes - NEMA	143/145TC and 182/184TC	182/184, 213/215
Motor Frame Sizes - IEC	100/112 B14 Face	100/112
Pump Housing Materials of Construction	Kynar	316L SS or Alloy C
Gear Materials of Construction	Modified PTFE	316L SS, Alloy C, Modified PTFE, or PEEK
Shaft Materials of Construction	Alumina Ceramic	316L SS, Alloy C, or Alumina Ceramic
Can Materials of Construction	Kynar	Alloy C
Magnet Materials of Construction	Neodymium Iron	Neodymium Iron
O-ring Seal Materials	Viton A, EPDM, or Kalrez	PTFE and Kalrez
Approximate Weight	43.7 lbs. (19.8 kg) less motor	Consult Factory

Eclipse 125 General Specifications	Non-Metallic	Metallic
Port Size and Type	1½" ANSI 150# / DIN 32/40 Flanged	1½" NPT or BSPT, 1½" ANSI 150# / DIN 32/40 Flange

Direction of Rotation	Bi-directional	Bi-directional
Theoretical Displacement	2.135 US gal / 100 rev. (80.82 cc / rev.)	2.135 US gal / 100 rev. (80.82 cc / rev.)
Maximum Differential Pressure	150 psig (10 bar, 1034 kPa)	150 psig (10 bar, 1034 kPa)
Maximum Allowable Working	200 psi (13.8 bar, 1379 kPa)	200 psi (13.8 bar, 1379 kPa)
Maximum Speed	1750 rpm	1750 rpm
Maximum Capacity at 0 psig	33 US gpm (125 lpm)	33 US gpm (125 lpm)
Maximum Viscosity	10,000cps	10,000cps
Maximum Process Fluid Temperature	150 F (66 C) at maximum differential pressure	150 F (66 C) at maximum differential pressure
Minimum Process Fluid Temperature	-40 F (-40 C)	-40 F (-40 C)
Fluid pH Range	0-14	0-14
Gear Type	Compact Spur Gear Design	Compact Spur Gear Design
Bearing Type	Sleeve Bearing Integral Wear Plate	Sleeve Bearing Integral Wear Plate
Bearing Material	Carbon or Silicon Carbide	Carbon, Silicon Carbide, or PTFE
Magnetic Torque Rating	668 in-lbs. (75.4 N-m)	Consult Factory
Motor Frame Sizes - NEMA	143/145TC, 182/184TC, 213/215TC, 254/256TC	182/184, 213/215
Motor Frame Sizes - IEC	100/112, 132 B14 Face	100/112
Pump Housing Materials of Construction	Kynar	316L SS or Alloy C
Gear Materials of Construction	Modified PTFE	316L SS, Alloy C, Modified PTFE, or PEEK
Can Materials of Construction	Kynar	Alloy C
Magnet Materials of Construction	Neodymium Iron	
O-ring Seal Materials	Viton A, EPDM, or Kalrez	PTFE and Kalrez
Approximate Weight	Approx. 44.7 lbs. (20.3 kg)	Consult Factory

29.1 General Specifications

Maximum Sound Levels	
Pump Size	Sound Level (dB)
Eclipse 02	80
Eclipse 05	81
Eclipse 12	82
Eclipse 25	83
Eclipse 75	85
Eclipse 125	95

Maximum Flange Loads – Non-metallic		
Pump Size	Flange Loads lb (N)	Flange Loads Ft-lb (N-m)
Eclipse 02	25 (111)	10 (13.5)
Eclipse 05	25 (111)	20 (27)
Eclipse 12	25 (111)	25 (33)
Eclipse 25	30 (133)	20 (27)
Eclipse 75, & 125	50 (222)	25 (34)

Maximum Flange Loads – Metallic		
Pump Size	Flange Loads lb (N)	Flange Loads Ft-lb (N-m)
Eclipse 02	25 (111)	10 (13.5)
Eclipse 05	25 (111)	20 (27)
Eclipse 12	30 (111)	30 (33)
Eclipse 25	40 (133)	30 (27)
Eclipse 75, & 125	65 (222)	35 (34)

Maximum Suction Lift (Dry or Wetted Pump)	
Pump Size	Feet (m)
Eclipse 02	3 (0.9)
Eclipse 05	3 (0.9)
Eclipse 12	3 (0.9)
Eclipse 25	5 (1.5)
Eclipse 75, & 125	5 (1.5)

NPSH Required
NPSHr = 2 ft (0.6m) at 1750rpm – All Sizes

Vacuum Systems – Flooded Suction
Maximum vacuum of 28 in-Hg (14 psi- gauge) or 0.1mm Hg (Absolute)

Solids Handling Capability
Size: 70 Microns / 0.003 inches / 0.07 mm
Maximum Concentrations: 10%
200 Mesh strainer recommended

Consult factory for metallic pump general specifications.

29.2 Torque Specifications

Pump Size	Bolt Position		Bolt Size	Recommended Torque	
				in-lb	N m
<i>Eclipse 02</i>	Non-Metallic	Front Cover -to- Housing	10 - 32	15	1.7
	Metallic	Front Cover -to- Housing	8 - 32	20	2.3
	Non-Metallic	Housing Adapter -to- Spool	1/4 - 20	48	4.5
	Metallic	Housing -to- Spool	3/8 - 16	40	4.5
	Spool -to- Motor Adapter or Motor		3/8 - 16	72	8.1
	Motor Adapter -to- Motor				
	56C		3/8 - 16	72	8.1
	63 B14		M5 - 0.80	24	2.7
	80 B14		M6 - 1.00	48	5.4
<i>Eclipse 05 and 12</i>	Non-Metallic	Front Cover -to- Housing	1/4 - 20	60	6.8
	Metallic	Front Cover -to- Housing	1/4 - 28	60	6.8
	Non-Metallic	Housing -to- Spool	1/4 - 20	60	6.8
	Metallic	Housing -to- Spool	1/4 - 28	60	6.8
	Spool -to- Motor Adapter or Motor		3/8 - 16	72	8.1
	Motor Adapter -to- Motor				
	56C		3/8 - 16	72	8.1
	143TC - 182C		3/8 - 16	72	8.1
	63 B14		M5 - 0.80	24	2.7
80 B14		M6 - 1.00	48	5.4	
<i>Eclipse 25</i>	Non-Metallic	Front Cover -to- Housing	1/4 - 20	72	8.1
	Metallic	Front Cover -to- Housing	1/4 - 28	60	6.8
	Non-Metallic	Housing -to- Spool	3/8 - 16	120	13.6
	Metallic	Housing -to- Spool	1/4 - 28	60	6.8
	Non-Metallic	Spool -to- Motor Adapter	3/8 - 16	120	13.6
	Metallic	Spool -to- Motor Adapter	1/4 - 28	60	6.8
	Base Mount -to- Spool		3/8 - 16	120	13.6
	Flange Bolts (min. to seal)		Varies	120	13.6
	Motor Adapter -to- Motor				
	56C		3/8 - 16	72	8.1
	143TC - 182C		3/8 - 16	120	13.6
	100 - 112 B14		M8 - 1.25	120	13.6
<i>Eclipse 75 and 125</i>	Non-Metallic	Front Cover -to- Housing	3/8 - 16	120	13.6
	Metallic	Front Cover -to- Housing	3/8 - 24	120	13.6
	Non-Metallic	Housing -to- Spool	3/8 - 16	120	13.6
	Metallic	Housing -to- Spool	3/8 - 16	120	13.6
	Non-Metallic	Spool -to- Motor Adapter	3/8 - 16	120	13.6
	Metallic	Spool -to- Motor Adapter	3/8 - 16	120	13.6
	Non-Metallic	Base Mount -to- Spool	3/8 - 16	120	13.6
	Non-Metallic	Motor Adapter -to- Motor			
	143TC - 182C		3/8 - 16	120	13.6
	1182TC - 184TC		1/2 - 13	120	13.6
	2213TC - 215TC		1/2 - 13	120	13.6
	2254TC - 256TC		1/2 - 13	120	13.6
	1100 - 112 B14		M8 - 1.25	120	13.6
	1132 B34		M8 - 1.25	120	13.6

30. Dimensional Drawings

30.1 Eclipse 02 Non-Metallic

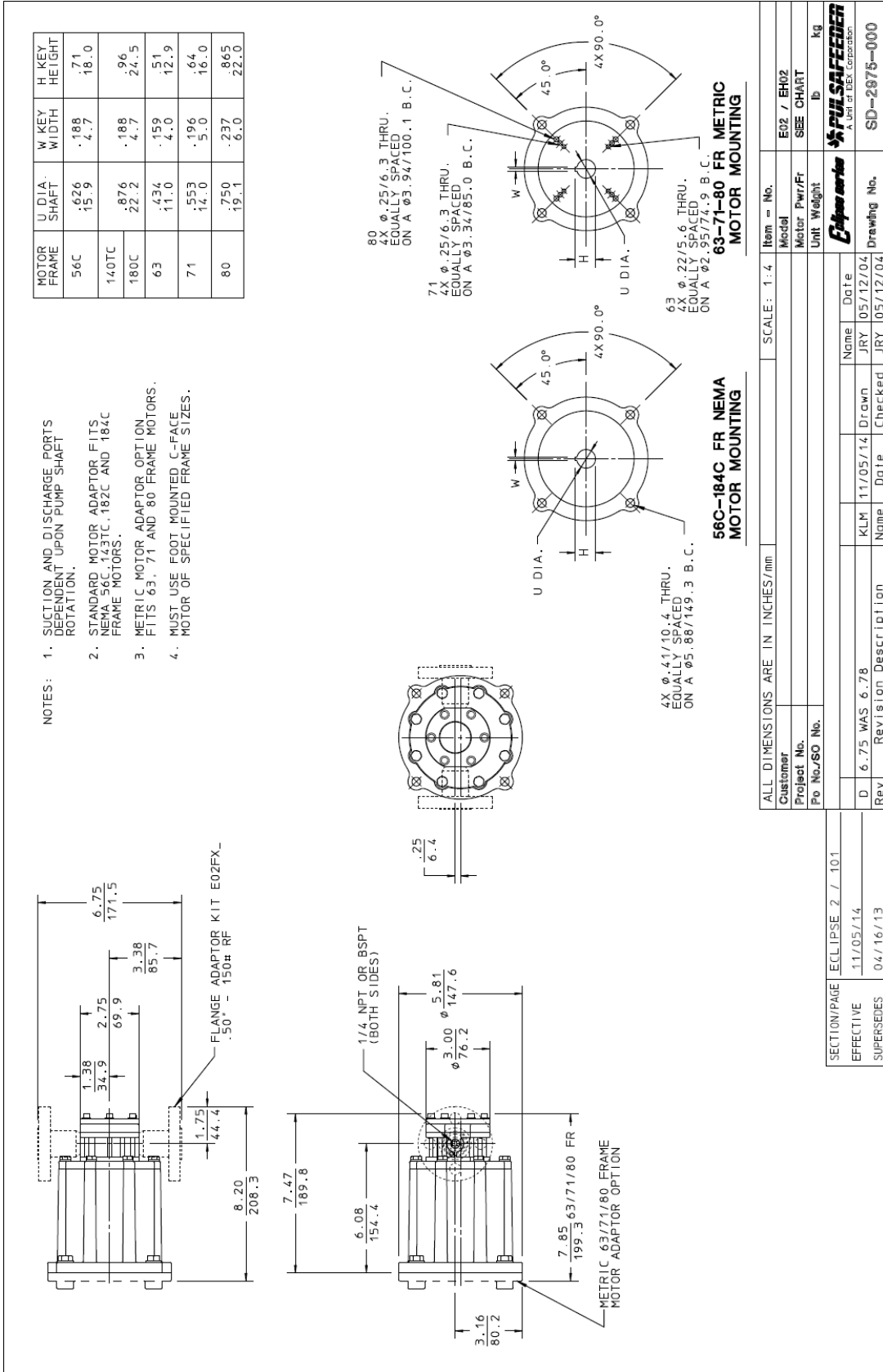

30.2 Eclipse 02 Metallic

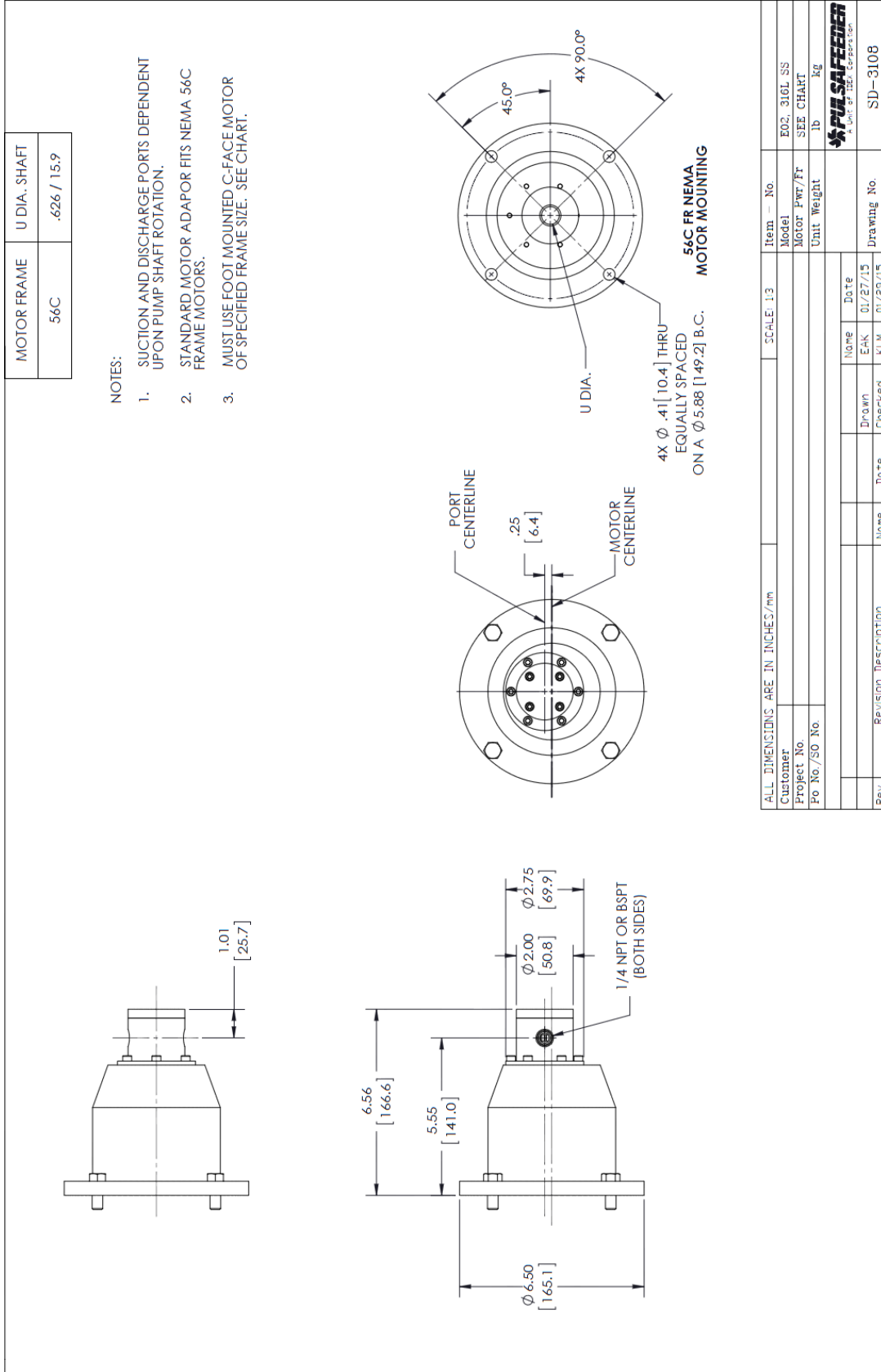

30.3 Eclipse 05 Non-Metallic

NOTES:

- SUCTION AND DISCHARGE PORTS DEPENDENT UPON PUMP SHAFT ROTATION
- STANDARD MOTOR ADAPTOR FITS NEMA 56C, 143TC, 182C AND 184C^{FR} FRAME MOTORS
- METRIC MOTOR ADAPTOR OPTION FITS 63, 71 AND 80 FRAME MOTORS.
- MUST USE FOOT MOUNTED C-FACE MOTOR OF SPECIFIED FRAME SIZES

56C-184C FR NEMA MOTOR MOUNTING

56C-184C FR NEMA MOTOR MOUNTING

63-71-80 FR METRIC MOTOR MOUNTING

E05 WITH FLANGE ADAPTOR KIT: E05FX.

MOTOR FRAME	U D.I.A. SHAFT	W KEY WIDTH	H KEY HEIGHT
56C	.626 15.9	.188 4.7	.71 18.0
140TC	.876 22.2	.188 4.7	.96 24.5
180C	.636 11.0	.159 4.0	.51 12.9
63	.553 14.0	.196 5.0	.64 16.0
71	.750 19.1	.237 6.0	.865 22.0

Customer	Project No.	Po No./SO No.	Section/Page	Effective	Supersedes
			ECLIPSE 3 / 101	12/21/07	6/23/05
ALL DIMENSIONS ARE IN INCHES/mm			SCALE: 1.4	Item - No.	
Customer			Model	ECLIPSE E05/EH05	
Project No.			Motor Pwr/PF	SEE CHART	
Po No./SO No.			Unit Weight	lb kg	
Rev			Name	Date	Name
E			ADDED .500 TO FLANGE WIDTH	06/11/13	Drawn JRY 05/12/05
Rev			Revision Description	Date	Checked JRY 05/12/05
Customer			Name		Date
Eclipse			JRY		05/12/05
Drawing No.			SD-2878-000		

30.4 Eclipse 05 Metallic

MOTOR FRAME	U DIA. SHAFT	W KEY WIDTH	H KEY HEIGHT
56C	.626 / 15.9	.188 / 4.7	.71 / 18.0
140TC	.876 / 22.2	.188 / 4.7	.96 / 24.5

NOTES:

- SUCTION AND DISCHARGE PORTS DEPENDENT UPON PUMP SHAFT ROTATION.
- STANDARD MOTOR ADAPTOR FITS NEMA 56C, 143TC, AND 145TC FRAME MOTORS.
- MUST USE FOOT MOUNTED C-FACE MOTOR OF SPECIFIED FRAME SIZE. SEE CHART.

1/2" - 150# ANSI / DIN 10/15 PN16
BOTH SIDES

FLANGE OPTION

56 - 140TC FR NEMA MOTOR MOUNTING

ALL DIMENSIONS ARE IN INCHES/mm

Customer	Item - No.	SCALE: 1:3
Project No.	Model	E05, 316L SS, ALLOY C
PO No./SO No.	Motor Pwr/Fr	SEE CHART
	Unit Weight	lb
		kg

Rev	ADD FLANGE OPTION DIMENSIONS	Name	Date
C		EAK	01/19/15
	Revision Description	KLM	01/19/15

Drawing No.	SD-3107_000
-------------	-------------

30.5 Eclipse 12 Non-Metallic

NOTES:

- SUCTION AND DISCHARGE PORTS DEPENDENT UPON PUMP SHAFT ROTATION
- STANDARD MOTOR ADAPTOR FITS NEMA 56C, 140TC, 182C AND 184C FRAME MOTORS
- METRIC MOTOR ADAPTOR OPTION FITS 63, 71 AND 80 FRAME MOTORS.
- MUST USE FOOT MOUNTED C-FACE MOTOR OF SPECIFIED FRAME SIZES

MOTOR FRAME	U D.I.A. SHAFT	W KEY WIDTH	H KEY HEIGHT
56C	.626 15.9	.188 4.7	.71 18.0
140TC			
180C	.876 22.2	.188 4.7	.96 24.5
63	.436 11.0	.159 4.0	.51 12.9
71	.551 14.0	.196 5.0	.64 16.0
80	.750 19.1	.237 6.0	.865 22.0

E12 WITH FLANGE ADAPTOR KIT E12FX.

56C-184C FR NEMA MOTOR MOUNTING

63-71-80 FR METRIC MOTOR MOUNTING

63-71-80 FR METRIC MOTOR MOUNTING

ALL DIMENSIONS ARE IN INCHES/MM

Customer	RHA	X	SCALE	X	X	Item = No.
Project No.						E12
Po No./SO No.						Motor Pwr/Ft
						SEE CHART
						Unit Weight
						lb
						kg

SECTION/PAGE	ECLIPSE 10 / 101
EFFECTIVE	11/05/14
SUPERSEDES	04/16/13

Rev	8	625 WAS 8 5 8 38 WAS 8 25	Name	KLM	Date	11/05/14	Drawn	PTP	Date	04/06/06
Revision Description			Name		Date		Checked	PTP	Date	10/4/06/06

Drawing No.	SD-2990-000
-------------	-------------

SAFEDER
A UNIT OF IBSA CORPORATION

30.6 Eclipse 12 Metallic

MOTOR FRAME	U DIA. SHAFT	W KEY WIDTH	H KEY HEIGHT
56C	.626 / 15.9	.188 / 4.7	.71 / 18.0
143-5TC	.876 / 22.2	.188 / 4.7	.96 / 24.5
182-4C			

FLANGE OPTION

NOTES:

- SUCTION AND DISCHARGE PORTS DEPENDENT UPON PUMP SHAFT ROTATION.
- STANDARD MOTOR ADAPTOR FITS NEMA 56C, 143-5TC, AND 182-4C FRAME MOTORS.
- MUST USE FOOT MOUNTED C-FACE MOTOR OF SPECIFIED FRAME SIZE. SEE CHART.

56C, 143-5TC, 182-4C FR NEMA MOTOR MOUNTING

ALL DIMENSIONS ARE IN INCHES/mm		SCALE: 1:3	Item - No.
Customer	Project No.	Po No./SD No.	Model
			EI2, 316L SS, ALLOY C
			SEE CHART
			Motor Pwr/Fr
			Unit Weight
			lb
			kg
Revision Description		Name	Date
B	A00 FLANGE OPTION DIMENSIONS	EAK	01/27/15
Rev		Created	KLM
		Date	01/29/15
			Drawing No.
			SD-3109_000

30.7 Eclipse 25 Non-Metallic

MOTOR FRAME	U DIA. SHAFT	W KEY WIDTH	H KEY HEIGHT	"C" DIM	"D" DIM
56C	626	188	71	69	11.60
	15.9	4.7	18.0	17.5	294.6
140TC	875	188	96	69	11.60
	22.2	4.7	24.5	17.5	294.6
180C	750	237	85	106.9	11.79
	19.0	6.0	22.0	27.2	295.5
90	946	317	107.5	104.4	11.79
	24.0	8.0	27.3	26.5	295.5
100	1110	317	124	69	11.60
	28.0	8.0	31.5	17.5	294.6

NOTES:

- SUCTION AND DISCHARGE PORTS DEPEND UPON PUMP SHAFT ROTATION
- STANDARD MOTOR ADAPTOR PLATE FOR NEMA 161T, 184C, 100TC AND 100/112 METRIC FRAME MOTORS.
- MUST USE C-FACE MOTORS OF SPECIFIED FRAME SIZES.

MOUNTING FOOT DIMENSIONS

ALL DIMENSIONS ARE IN INCHES/mm SCALE 1:4

Customer	E25 / EH25
Project No.	56-184C / IEC 100,112
Po No./SO No.	
Motor Pwr/Fr	lb
Unit Weight	kg

SECTION/PAGE ECLIPSE 8 / 101

EFFECTIVE 08/05/13

SUPERSEDES 04/16/13

Name	Date
JRY	05/12/04
Checked	
JRY	05/12/04
Drawn	
KLM	08/05/13
Revision Description	
Rev	
Added	80/90 FR MOTOR

Item No. 14

Model E25 / EH25

Motor Pwr/Fr 56-184C / IEC 100,112

Unit Weight lb kg

Eclipse A Unit of IBS Corporation

Pulsafeeder A Unit of IBS Corporation

Drawing No. SD-2977-000

30.8 Eclipse 25 Metallic

FLANGE OPTION

10.00 [253.9]
5.00 [127.0]
4.62 [117.3]
2X .63 [15.9]
3/4" - 150# ANSI / DIN 20 PN16 BOTH SIDES

1.66 [42.1]
3.32 [84.3]

8.88 [225.6]
6.48 [164.5]
4.88 [123.8]
1/8 NPT DRAIN
3/4 NPT OR BSPT (BOTH SIDES)
1/8 NPT DRAIN
φ 6.75 [171.5]

PORT CENTERLINE
MOTOR CENTERLINE
.63 [15.9]

U DIA.
H
W
45.0°
4X 90.0°
4X φ .44 [11.2] THRU EQUALLY SPACED ON A φ 5.88 [149.2] B.C.

56C, 143-5TC, 182-4C FR NEMA MOTOR MOUNTING

NOTES:

- SUCTION AND DISCHARGE PORTS DEPENDENT UPON PUMP SHAFT ROTATION.
- STANDARD MOTOR ADAPTOR FITS NEMA 56C, 143-5TC, AND 182-4C FRAME MOTORS.
- MUST USE FOOT MOUNTED C-FACE MOTOR OF SPECIFIED FRAME SIZE. SEE CHART.

MOTOR FRAME	U DIA. SHAFT	W KEY WIDTH	H KEY HEIGHT
56C	.626 / 15.9	.188 / 4.7	.71 / 18.0
143-5TC	.876 / 22.2	.188 / 4.7	.96 / 24.5
182-4C			

ALL DIMENSIONS ARE IN INCHES/mm		SCALE: 1:3	Item - No.
Customer			Model E25, 316L SS, ALLOY C
Project No.			Motor Pwr/Fr SEE CHART
Part No./SO No.			Unit Weight lb kg
ADD FLANGE OPTION DIMENSIONS		Name	Date
Revision	Description	EAK	1/29/16
		KLM	01/29/15
		Checked	01/29/15
		Drawn	01/27/15
		Name	
		Drawing No.	SD-3110_000

30.9 Eclipse 75/125 Non-Metallic

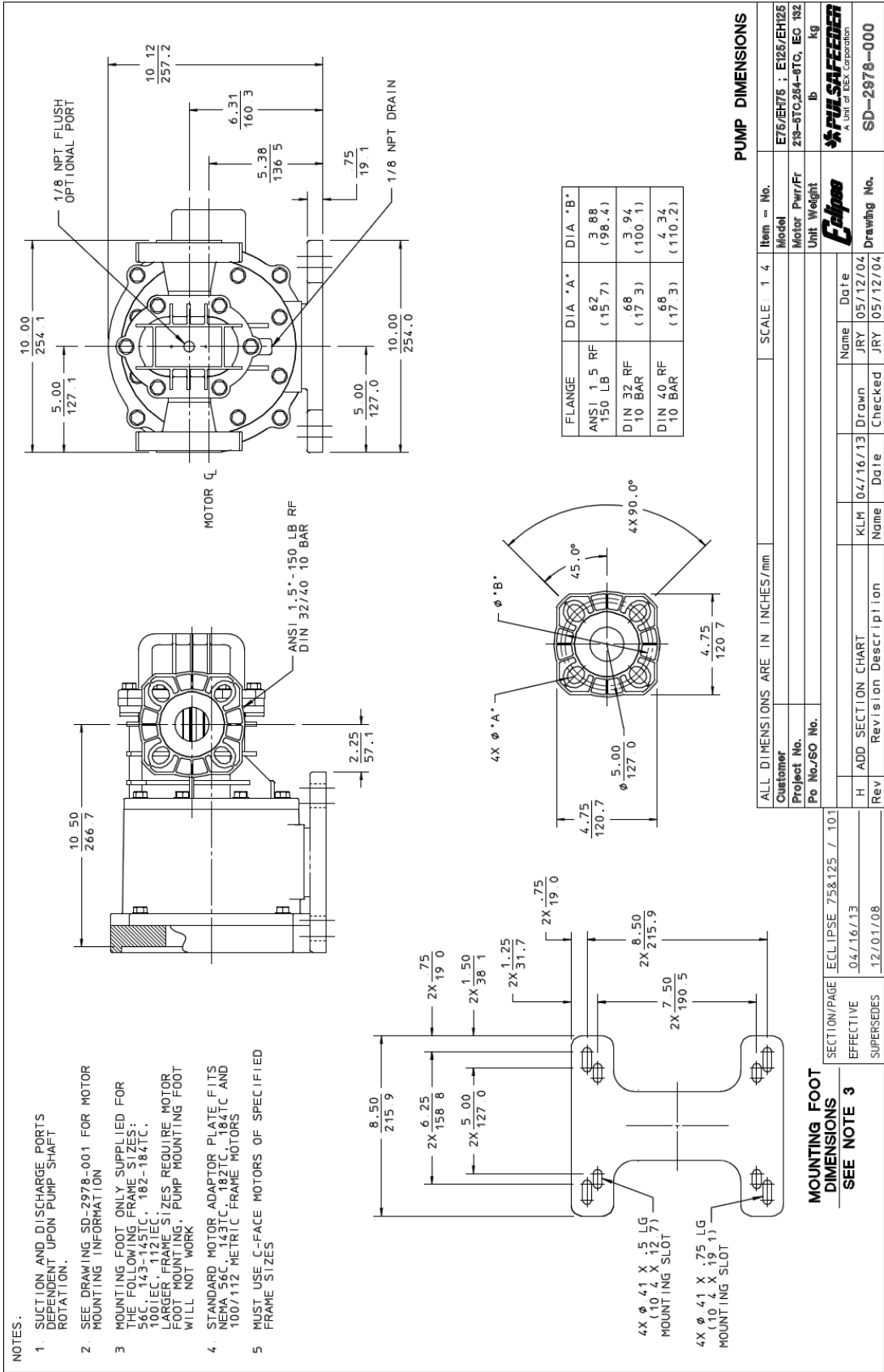

31. Performance Curves

31.1 Eclipse2

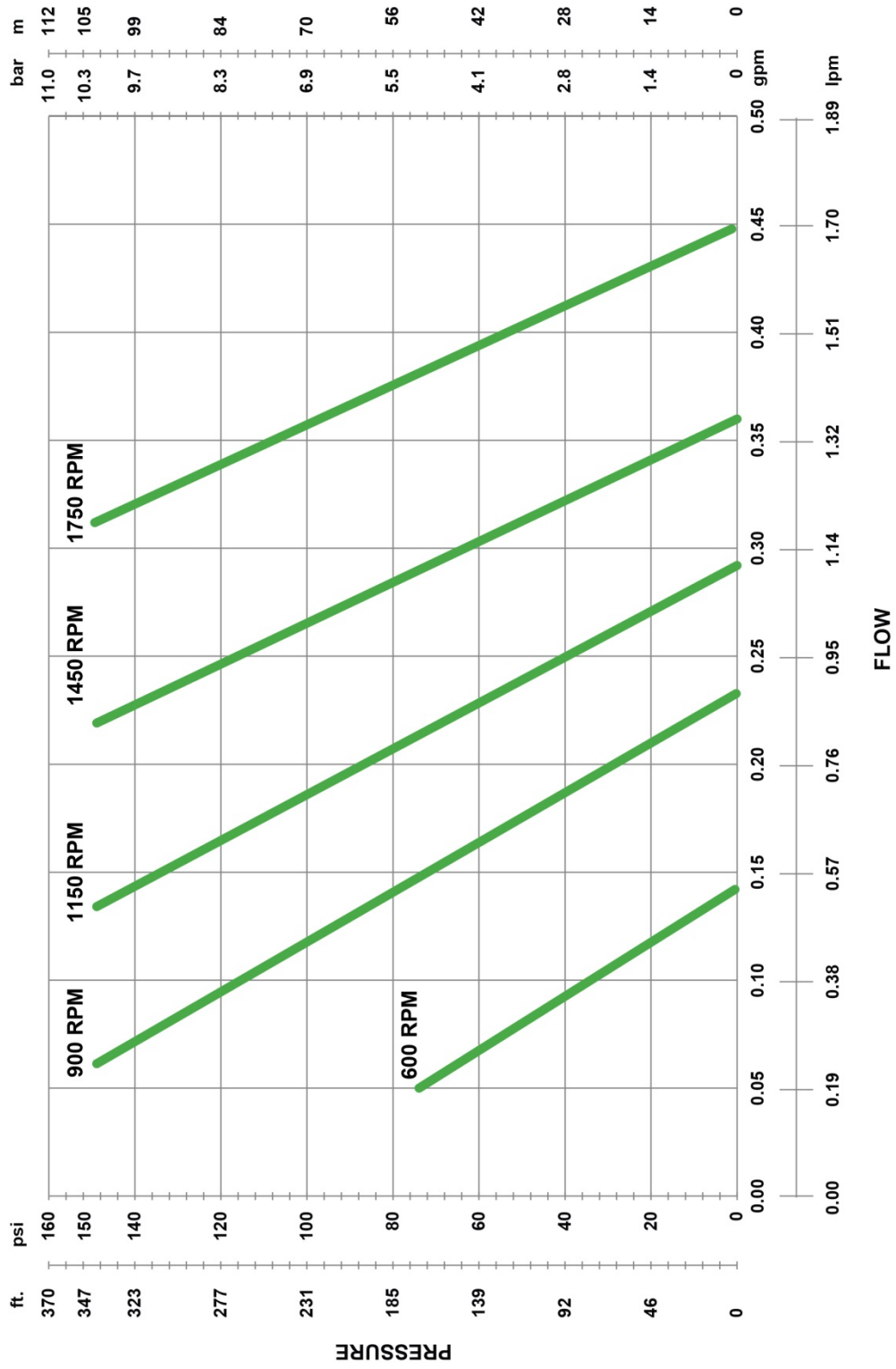

31.2 Eclipse 05

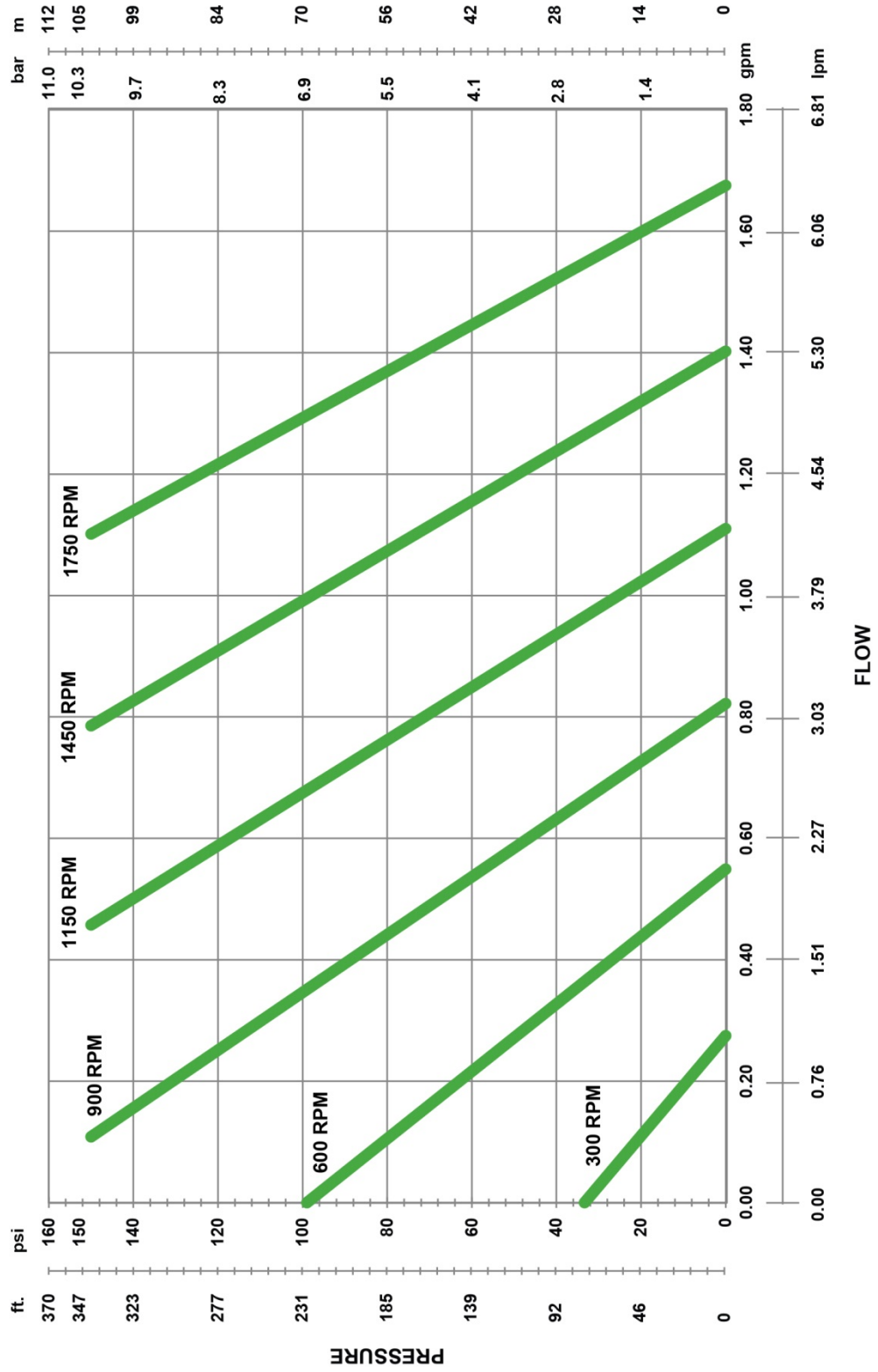

31.3 Eclipse 12

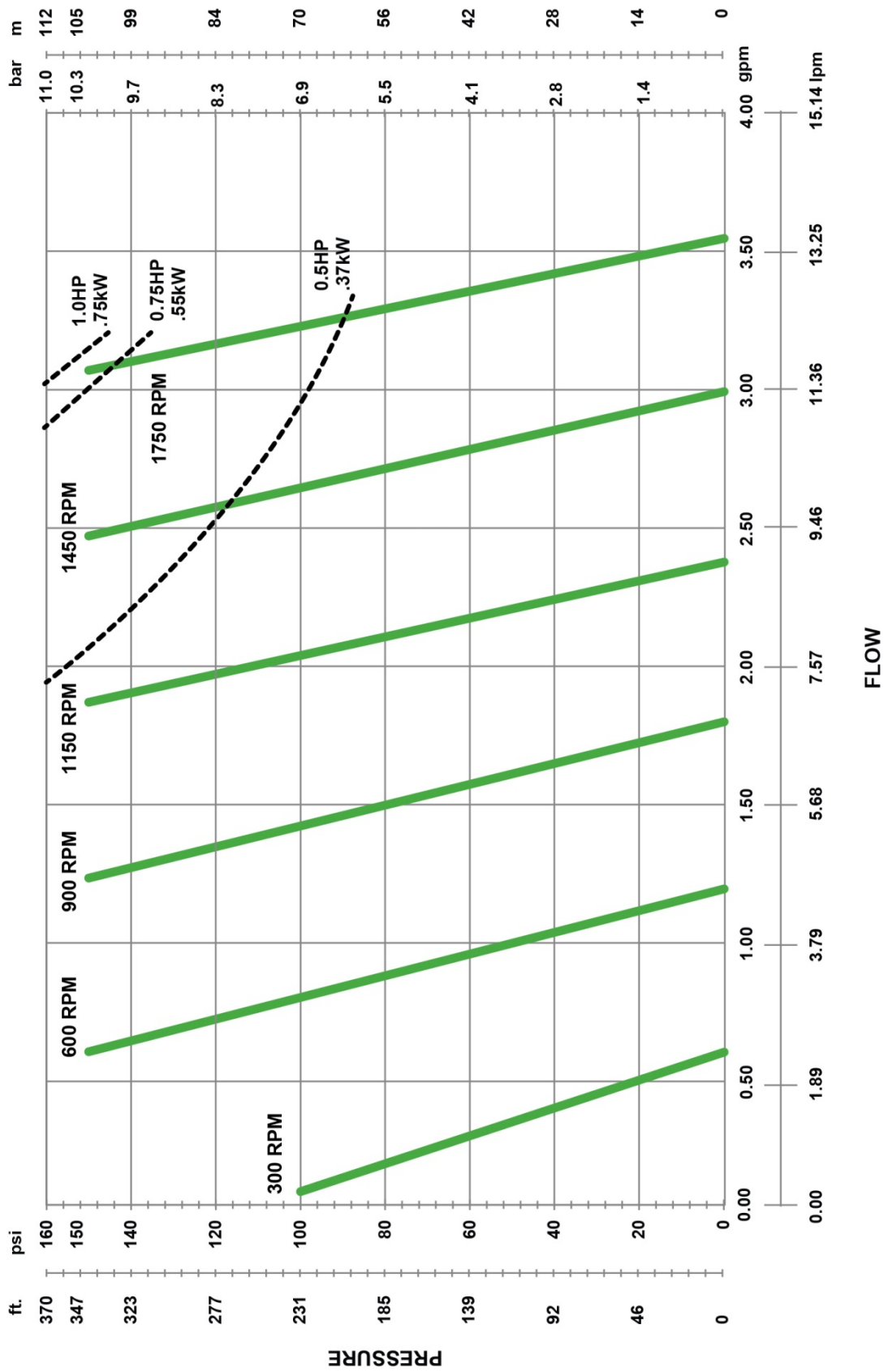

31.4 Eclipse 25

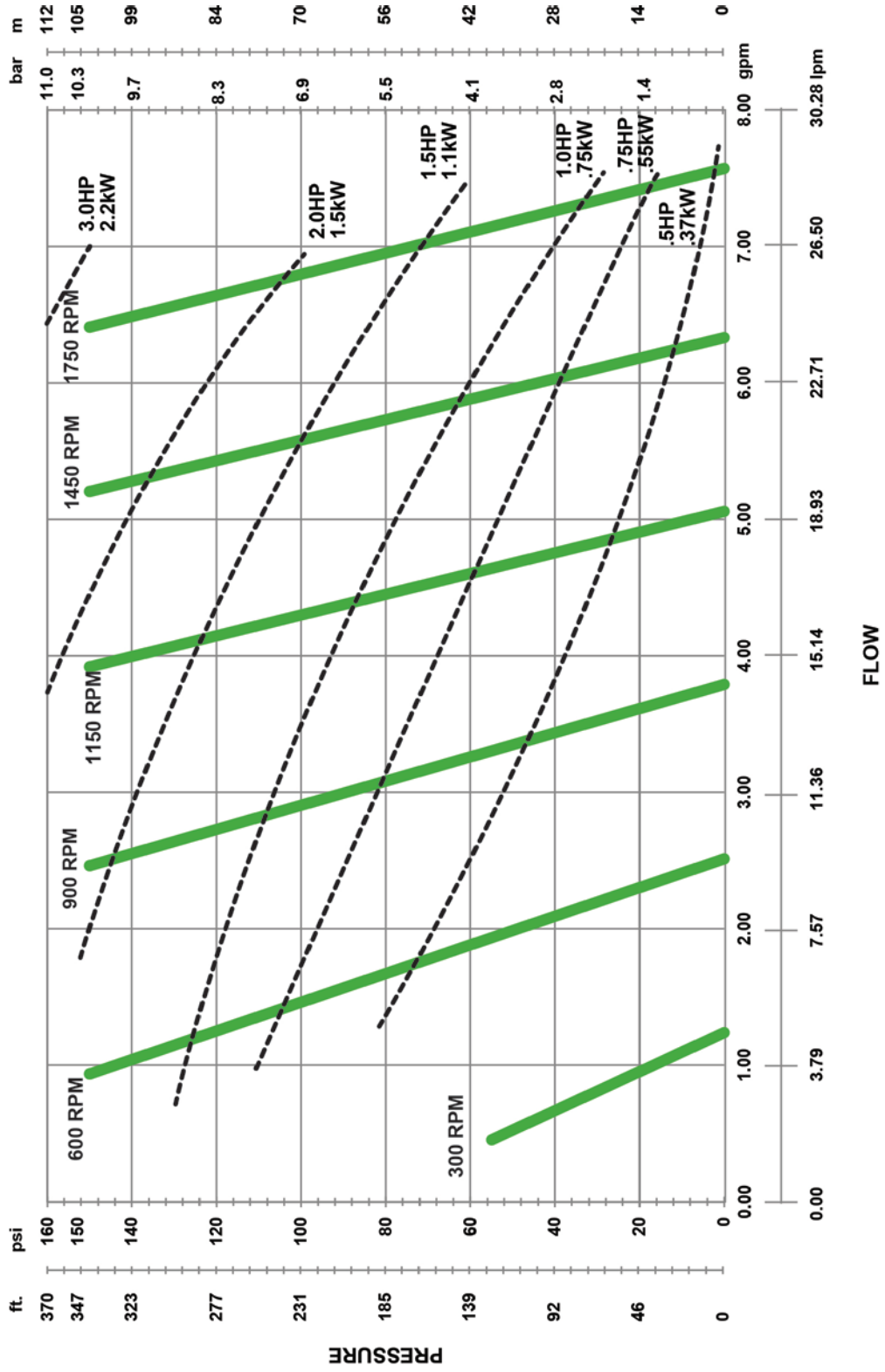

31.5 Eclipse 75

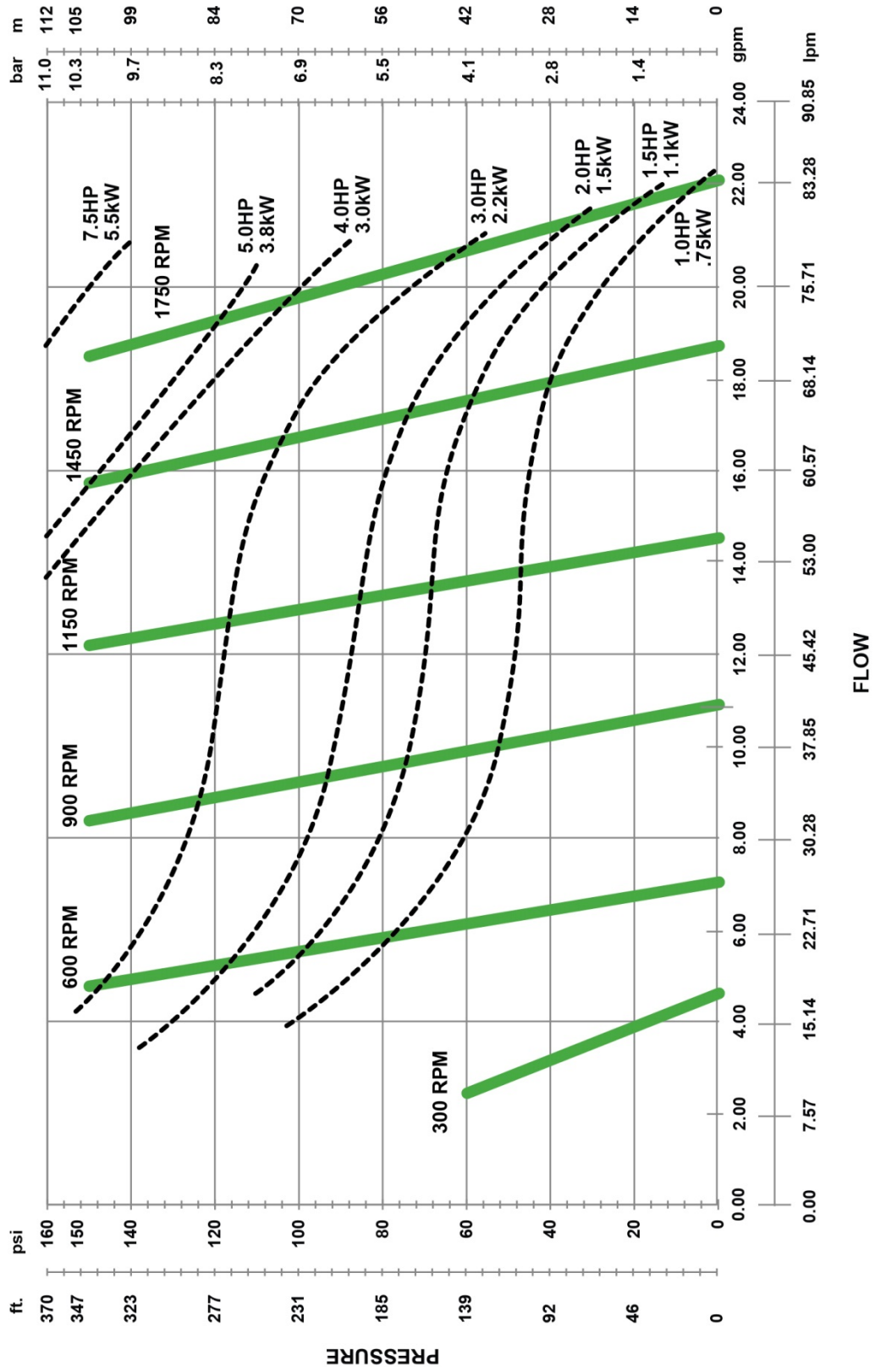

31.6 Eclipse 125

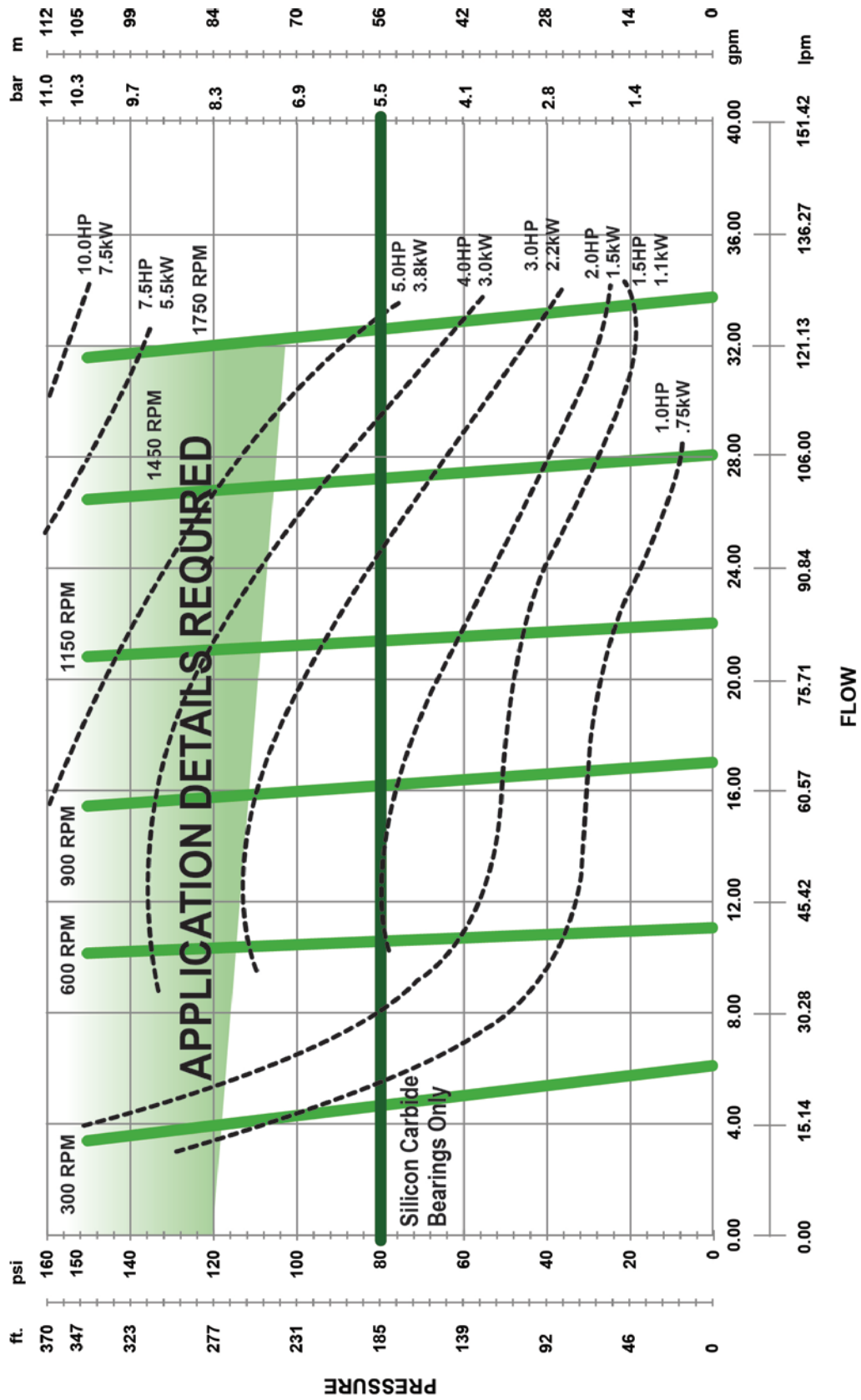



ECLIPSE[®]

EXTERNAL GEAR METERING PUMP

Bulletin: IOM-ECL-3500 Rev I



Pulsafeeder, Inc.
A unit of IDEX Corporation
2883 Brighton Henrietta Town Line Road
Rochester NY 14623
+1 (585) 292-8000
www.pulsa.com
pulsa@idexcorp.com

IDEX
FLUID & METERING