

ARGAL

USE MANUAL EQUIPRO

HME



EAC CE

DEALER

For maintenance:
date of commissioning

References: position/system reference

Service:

INDEX

- 3- IDENTIFICATION CODE**
- 5- LEGEND**
- 6- GENERAL INFORMATION**
- 6- STRUCTURE**
- 7- APPLICATION LIMITS**
- 8- MOTOR**
- 8- INSTRUCTIONS ON INSTALLATION AND USE**
- 8- TRANSPORT INSTRUCTIONS
- 8- STORAGE INSTRUCTIONS
- 9- INSTALLATION INSTRUCTIONS
- 10- STARTUP
- 10- USE
- 11- MAINTENANCE**
- 11- DISASSEMBLY
- 12- INSPECTION
- 12- SAFETY RISKS**
- 12- INSTALLATION AND START-UP PERSONNEL
- 12- MAINTENANCE AND OPERATIONAL PERSONNEL
- 12 PERSONNEL RESPONSIBLE FOR REPAIRS
- 13- WASTE DISPOSAL
- 13- IMPROPER USE
- 14- MALFUNCTIONS AND POSSIBLE CAUSES**
- 15- TECHNICAL DATA - IEC 50Hz**
- 17- TECHNICAL DATA - IEC 60Hz**
- 19- GENERAL CONDITIONS OF SALE**
- 21- WARRANTY FORM**
- 24- MANUFACTURER DATA**

ATTACHMENTS

- DECLARATION OF CONFORMITY (MACHINERY DIRECTIVE 2006/42/EC)
- MOTOR USE MANUAL

IDENTIFICATION CODE

pump data					motor data				
serie	model		execution (materials)		connections	rpm	power	phase	
HME	<input type="checkbox"/> 04.08	<input type="checkbox"/> 05.11	<input type="checkbox"/> WR (polypropylene PP)		<input type="checkbox"/> BC (BSP no base plate)	<input type="checkbox"/> 2900	<input type="checkbox"/> 0,37 kW	<input type="checkbox"/> 1	
	<input type="checkbox"/> 06.08	<input type="checkbox"/> 07.09	<input type="checkbox"/> FC (polyvinyl fluoride E-CTFE)		<input type="checkbox"/> NC (NPT no base plate)	<input type="checkbox"/> 3500	<input type="checkbox"/> 0,55 kW	<input type="checkbox"/> 3	
	<input type="checkbox"/> 06.10	<input type="checkbox"/> 07.11			<input type="checkbox"/> ZC (flange ISO-ANSI no base plate)		<input type="checkbox"/> 0,75 kW		
	<input type="checkbox"/> 10.10	<input type="checkbox"/> 07.15				<input type="checkbox"/> 1,1 kW	voltage/EEX		
	<input type="checkbox"/> 10.15	<input type="checkbox"/> 11.15	version			<input type="checkbox"/> BP (BSP with base plate)	<input type="checkbox"/> 1,5 kW	<input type="checkbox"/> 0 (without motor)	
	<input type="checkbox"/> 16.15	<input type="checkbox"/> 11.23	<input type="checkbox"/> N normal			<input type="checkbox"/> NP (NPT with base plate)	standard	<input type="checkbox"/> 2,2 kW	<input type="checkbox"/> N (STD voltage)
	<input type="checkbox"/> 16.20	<input type="checkbox"/> 17.25	<input type="checkbox"/> P powered			<input type="checkbox"/> ZP (flange ISO-ANSI with base plate)	<input type="checkbox"/> E (IEC)	<input type="checkbox"/> 3 kW	<input type="checkbox"/> S (special voltage)
	<input type="checkbox"/> 20.20	<input type="checkbox"/> 23.25	<input type="checkbox"/> S strong powered				<input type="checkbox"/> N (NEMA)	<input type="checkbox"/> 4 kW	<input type="checkbox"/> E (EEX)
	<input type="checkbox"/> 20.25	<input type="checkbox"/> 35.25					<input type="checkbox"/> 5,5 kW		
	<input type="checkbox"/> 30.25	<input type="checkbox"/> 35.30	O-ring	under plate lenght			<input type="checkbox"/> 7,5 kW		
	<input type="checkbox"/> 30.30		<input type="checkbox"/> V (FPM)	mm:					
			<input type="checkbox"/> E (EPDM)						

Each pump is supplied with the serial and model abbreviation and the serial number on the rating plate, applied onto the support side. Check these data upon receiving the goods. Any discrepancy between the order and the delivery must be communicated immediately.

In order to be able to trace data and information, the abbreviation, model and serial number of the pump must be quoted in all correspondence.

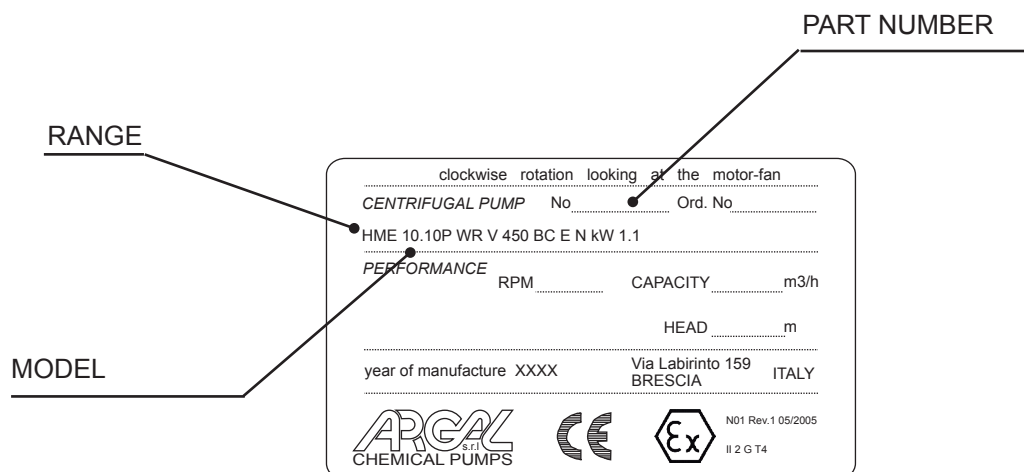

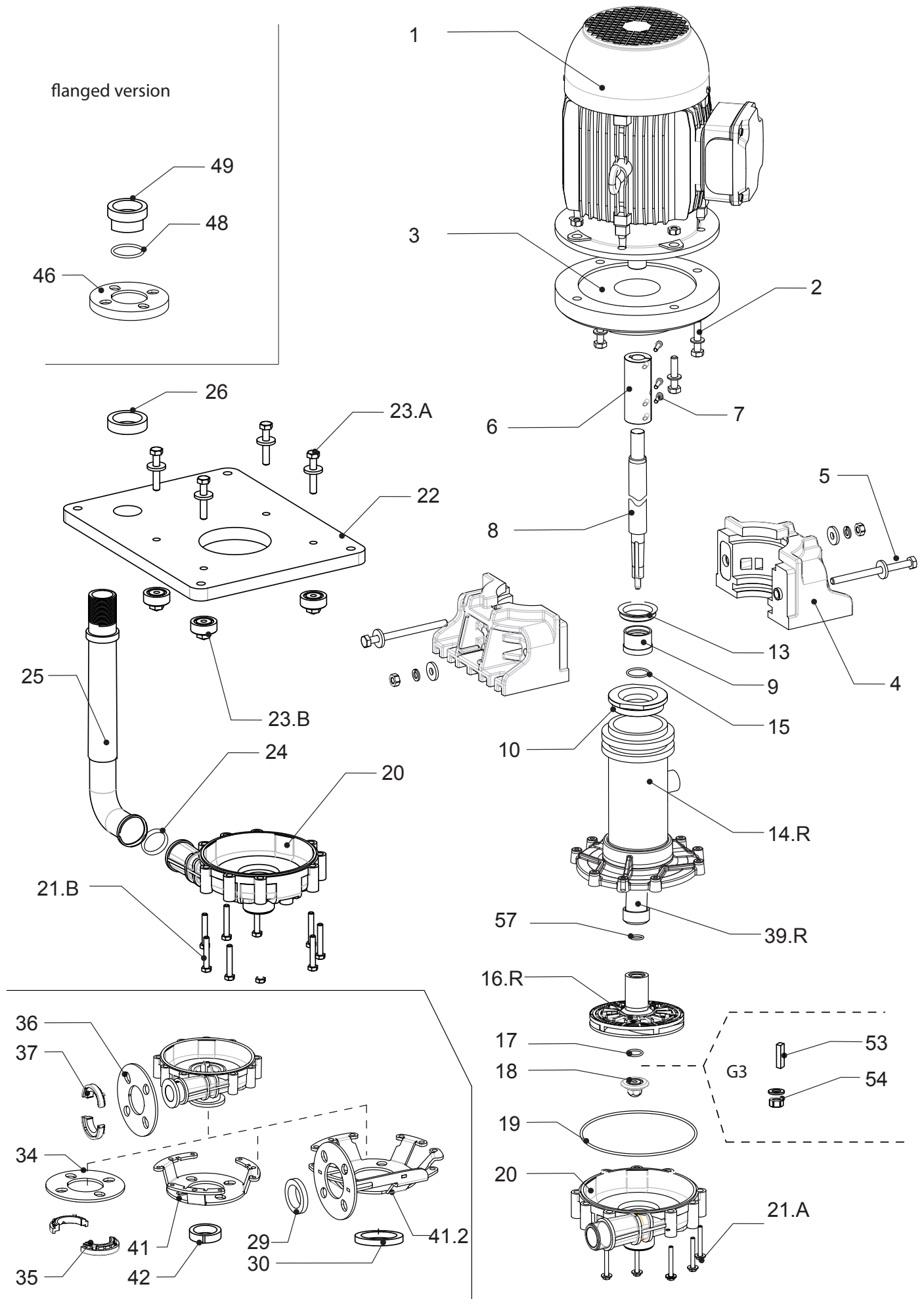

LEGEND

note	ref	pos.	Part name	Q.ty	Disassembling steps sequence										Spare stock		
					1	2	3	4	5	6	7	8	9	10	start up	2 year	
	801	1	Electric Motor	1										•			
	910.1	2	Fixing Set: flange / motor	1								•					
	807	3	Motor Lock Flange	1									•				
	193	4	Base Bracket	2							•						
	910.2	5	Fixing Set: base bracket	1					•								
	841	6	Coupling	1										•			
	910.3	7	Fixing Set: flexible coupling / shaft	1								•					
	210	8	Shaft	1										•			
	420	9	Ending Coating (upper)	1										•			1
	475	10	Counterface of Vapour Seal Ring	1								•					1
	421	13	V-ring	1											•	1	2
	711	14.R	Column	1													
	412.3	15	O-ring: shaft coating/vapour seal ring	1											•		1
	233	16.R	Centrifugal Impeller	1					•							1	1
	412.4	17	O-ring: ogive	1					•								1
	260	18	Ogive	1					•								1
	412.5	19	O-ring of volute casing (only with hydraulic connections BC - NC - ZC)	1													1
	102	20	Volute Casing	1						•							
	910	21	Fixing Set of volute casing	1													
	910.3	21.A	Fixing Set of volute casing (hydraulic connections: BC - NC - ZC)	1													
	910.4	21.B	Fixing Set of volute casing (hydraulic connections: BP - NP - ZP)	1													1
	893	22	Base Plate	1										•			
	910.5	23.A	Fixing Set: base plate / base bracket	1													
		23.B	Cap-Nut	4													
	412.10	24	O-ring: volute casing / discharge pipe	1													1
	700	25	Discharge Pipe	1													
	734	26	Lock Threaded Ring (outlet)	1													
	910.6	27	Locking Screw (coupling)	1													
	932.1	29	Armour Front Seeger - G3 (outlet)	1													
	932.2	30	Armour Front Seeger - G3 (inlet)	1													
	722.1	34	Inlet Flange (G1-G2 Models)	1													
	727.1	35	Inlet Flange-Adaptor (G1-G2 Models)	1													
	722.2	36	Outlet Flange (G1-G2 Models)	1													
	727.2	37	Outlet Flange-Adaptor (G1-G2 Models)	1													
	727	39.R	Shaft coating	1										•			
	195.1	41.1	Pump-casing Armour (G2 Models)	1													
	195.2	41.2	Pump-casing Armour (G3 Models)	1													
	932.3	42	Seeger Ring (G2 Models)	1													
	729	46	Outlet Flange	1													
	412.11	48	O-ring	1													
	722.3	49	Flange Adaptor	1													
	940.2	53	Key (UNI 6604-A 6x6x20) (only in G3 Models)	1													
	910.6	54	Fixing Set: shaft / impeller (only in G3 Models)	1													
	412.9	57	O-ring	1													

GENERAL INFORMATION

“HME” pumps are designed and built for the transfer of liquid chemical products having a specific weight, viscosity, temperature and stability of state appropriate for use with centrifugal pumps in a fixed installation, from a tank at a lower level to a tank or a pipe to a higher level. The characteristics of the liquid (pressure, temperature, chemical reactivity, specific weight, viscosity, vapour tension) and the environmental conditions must be compatible with the characteristics of the pump and are defined upon ordering. Impeller and static casings, in contact with the liquid, are constructed from thermoplastic materials; other parts in high chemical-resistant materials.

The pump's performance (capacity, head, rpm) is defined upon ordering and specified on the identification plate.

HME series pumps are centrifugal; they are vertical with a cantilever shaft at the bottom part, single-stage with body directly immersed in the liquid to be pumped, connected by a rigid coupling to the normalised asynchronous electric motor, with hydraulic axial suction connections facing downwards and with radial delivery or, upon request, connected to vertical piping that positions the connection to a hydraulic system outside the tank; the support plate must be fastened to a rigid support structure (see INSTALLATION INSTRUCTIONS)

The HME series pumps are not self-priming and, therefore, they must always be started with the body immersed. Once the pump has been started, the level must not drop below the minimum level in order to avoid the defusing of the pump.

HME series pumps can run dry occasionally when liquid is absent, but not for periods longer than 15 minutes; to resume pumping the pump body must be immersed.

Clockwise rotation seen from the motor side.

Make sure that the chemical and physical characteristics of the liquid have been carefully evaluated for pump suitability.

The maximum pressure that the pump can be subjected to is 1.5 times the maximum prevalence value. The pump must not operate with the delivery closed

The submerged part (liner) must not be subject to lateral hydrodynamic thrusts by the liquid mass being moved.

The pump does not include any non return valve nor any liquid flow control or motor stop device.

When calculating the head, consider the actual level of the liquid in the suction tank and not the outlet connection.

STRUCTURE

The mechanical structure is extremely simple: the impeller is pulled in rotation by the pump shaft connected to the motor shaft by a rigid coupling; the counter rotation of the impeller and a labyrinth reduce fluid leakage towards the shaft; dynamic loads, usually reduced in this type of pump, are supported by the motor bearings.

The pump is supplied with a support plate to fasten it to the supports that must be pre-mounted on the system.

The discharge pipe, where it crosses the base plate, is provided with threaded collar (pipe clamp ring) and a lock nut which, by fastening it to the plate, prevents the volute casing from being affected by mechanical stress from the system. It is absolutely necessary to reduce to a minimum any load on the connections. To do that, back the piping up with proper brackets in such a way to allow thermal expansions (e.g.: expansion coupling, proper configuration).

The pump shaft (coated), where it crosses the base plate, is provided with fume seal ring to protect the motor bearing and to reduce fume dispersion in the environment in case of hot liquids

APPLICATION LIMITS

The ambient temperature interval is related to the choice of materials (specified on the identification plate):

0 ÷ +40°C	execution WR
-10 ÷ +40°C	execution FC

The maximum continuous working temperature referred to water depends on the choice of materials (specified on the identification plate)

70°C	execution WR
90°C	execution FC

Immersion depth can be increased by adding a suction extension in order to prevent mud sediment in the tank (nevertheless ensure minimum distance from the bottom "S"). Should the extension-length be higher than 250 mm, arrange for a bracket to keep lateral movements of the extension within 1-3 mm. without blocking it and allowing at the same time thermal dilatation. The maximum length of the extension is 500 m; the nominal bore must be the same as the one of the pump inlet.

The liquid being pumped may contain a maximum 20% of solid non-abrasive particles not greater than 1 mm in size. The presence of fibrous, adhesive or abrasive bodies is not allowed. The maximum allowed size for bodies occasionally present is 3 mm. As to the FC execution, the maximum allowed concentration of metallic particles is 0,5% provided that their size is lower than max. 0,5 mm. Arrange for proper filtering or sedimentation stages to comply with above mentioned limits.

The specific weight which can be pumped at a temperature of 25°C (both of the liquid and the ambient) depends upon the diameter of the impeller (shown on the identification plate) and the installed motor power (shown on the motor identification plate) and has to be defined upon ordering.

The level of kinematic viscosity must not exceed 25 cSt so as not to significantly modify the pump's performance. Higher values up to a maximum of 75 cSt are possible provided that the pump is equipped with suitable impeller and motor to be defined upon ordering.

The vapour pressure value of the liquid to be pumped must exceed (by at least 1,5 m w.c) to the difference between the absolute total head (suction side pressure added to the positive suction head, or subtracted by the suction lift) and the pressure drops in the suction side piping (including the filter-drops and the inlet NPSHr drops shown on the specific tables).

MOTOR

Use motor type V1 (IM 3011) only. We suggest to install motor with increased bearing for high cantilever forces.

Electrical connections

The electrical connection to the motor terminal determines the direction of rotation of the motor and can be verified by looking at the cooling fan at the rear of the motor (for the Argal pump this has to rotate clockwise looking at the front end).

With single phase motors the direction of rotation may be reversed by changing the position of the connection plates(fig.1)

With three-phase motors the direction of rotation may be changed by swapping any two of the three conductors independently of the type of connection to the windings(fig.2)

The windings of three-phase motors (e.g. with (a) 230-400 V; (b) 400-600 V) require a delta-connection for lower voltage (230 volts for a ; 400 volts for b)(fig.3)

They require a star-connection for higher voltage (400 volts for a; 690 volts for b)(fig.4)

Star/Delta starting is used when the motor power is above 7.5 kW (10 HP) only in case of frequent starts and short running times, but always when the motor power is above 15kW (20 HP). All this is also to safeguard the structure of the pump.

Protection level

The initials IP are followed by two numbers :

The first number indicates the level of protection against penetration of solid objects and in particular :

- 4 for solids whose dimension is greater than 1mm
- 5 for dust (eventual internal deposits will not harm operation)
- 6 for dust (no penetration)

The second number indicates the protection against the penetration of liquids. In particular:

- 4 for water sprays from all directions
- 5 for jets of water from all directions
- 6 for tidal and sea waves.

According to the IP protection indicated on the identification plate of the motor and to the environmental conditions, arrange for opportune extra protections allowing in any case correct ventilation and rapid drainage of rainwater.

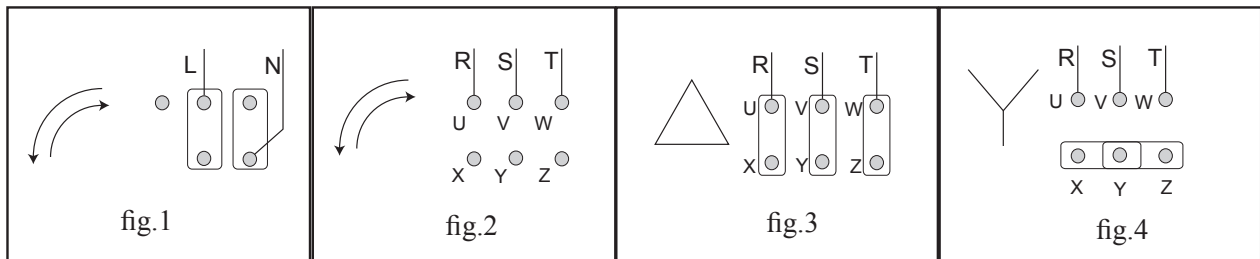

INSTRUCTIONS ON INSTALLATION AND USE

TRANSPORT INSTRUCTIONS

- cover the hydraulic connections
- when lifting the unit do not exert force on the plastic fittings
- lay the pump on its base or fixing plate during transport
- if the road is particularly rough, protect the pump by means of adequate shock absorbing supports
- bumps and shocks may damage important working parts vital for safety and functionality of the machine

STORAGE INSTRUCTIONS

- When is necessari to store the pump before installation don't remove it from the original packaged. The packaged pump must be stored lifted from ground level, the ambient must be close, clean and dry.
- If at the receipt of the pump package seems damaged is necessary to free the pump in order to check its integrity and to store a new package
- The place where the pump is stored must be closed with an ambient temperature not lower than -5°C and not higher than 40°C , the air humidity rate not higher than 80%, the package pump mustn't received shock, vibrations and loads rising above.
- If the storing period is higher than 6 months, before installation check the condition of the grease in the support, eventually provide to restore it.

INSTALLATION INSTRUCTIONS

arrange for a particularly rigid carrying structure: maximum deflection lower than 0.2 mm referred to the pump weight on the installation site

paint the carrying structure with epoxydic enamel or similar to prevent corrosion

arrange for adequate passage and install protection guards for people safety; act in compliance with the relevant safety rules

for motors: fit additional protection guards in case of outdoor installation: make sure that the motor impeller is duly ventilated and rain-water is quickly drained

the tanks under the pump must be covered in case of hot liquids or liquids emitting corrosive fume (dangerous for the metallic part of the pump outside the tank). Seal the plate base by means of thin, not soft seals, well compressed by the locking screws

do not use anti-vibration mounts to fix the pump

anti-vibration joints are recommended on the outlet pipe connection

clean the plant before connecting the pump

make sure that no foreign bodies are left in the pump. Remove safety caps on the hydraulic connections.

follow the instructions indicated in the following diagram:

01) YES: flow control valve on the discharge side

02) YES: non-return valve (particularly with long vertical or horizontal pipe runs; mandatory with pumps in parallel)

03) YES: connection point for pressure gauge or safety pressure switch

04) YES: firmly fix all piping by suitable brackets, close to the pump; YES: expansion joint (indispensable with long piping or hot liquids)

05) Maximum fluid speed on the discharge side: 3 m/sec

06) YES: divert discharge (by means of 45° bend) in order to avoid hindrance over the plate (free space is required to lift the pump). NO: bends (or other fittings) close to the pump (both at inlet and outlet)

07) Min. suction during startup; for suction head during pumping see "APPLICATION LIMITS"

08) A vertical suction extension for bottom suction lift is allowed (NO for emptying tank).

09) YES: foot strainer (3-5 mm mesh screen) if solid bodies (open tanks) or rough impurities are present

10) Arrange for drainage of liquids from the base plate

11) Use all of the fixing holes provided to install the pump; the fixing points must be kept at the same level

12) Ensure lowest distance from the bottom "S" and the wall (or from other working pumps)

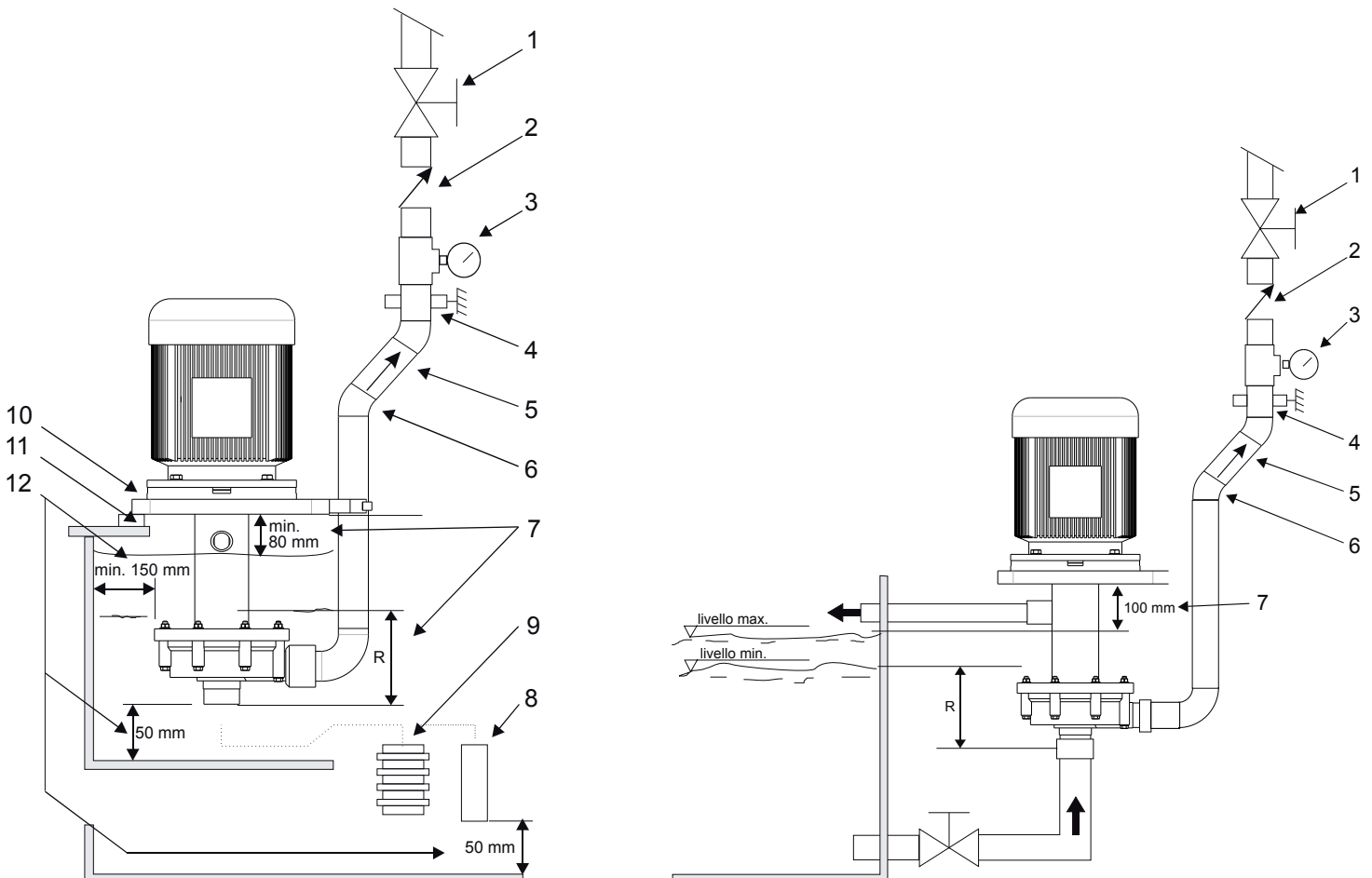

manually verify that all rotating parts are free to turn without abnormal friction by turning the motor cooling fan
 make sure that the power supply is compatible with the data shown on the pump motor identification plate
 connect the motor to the power supply via a magnetic/thermal control switch
 install emergency stop devices to switch off the pump in case of low liquid level (floating, magnetic, electronic, pressure-sensitive)
 ambient temperature as a function of the physical-chemical characteristics of the liquid to be pumped and in any case not greater or lower than the interval indicated in the GENERAL NOTES
 other environmental conditions in accordance with the IP protection of the motor
 leave enough free space around the pump for a person to move
 leave enough free space over the pump for lifting operation
 arrange for a rigid wall to separate the inlet ports in case of pumps installed close to each other
 pump axis must not be positioned in the center of small tanks
 highlight the presence of aggressive liquids with coloured tags following the local safety regulations
 do not install the pump (made in thermoplastic material) in close proximity to heating apparatus
 do not install the pump in areas subject to solid or liquid matter falling
 do not install the pump in an explosive atmosphere unless the motor and its coupling have been adequately pre-arranged
 do not install the pump in close proximity to workplaces or crowded areas
 install extra protection guards for the pump or persons as the need arises
 install a spare equivalent pump in parallel
 - CAUTION: in case of application the pump out of tank, the locking bolts of the volute casing (pos.21A / 21B) must be replaced with bolts in metal material (AISI 304 -AISI 316). The pumps are always built for installation in the tank, with bolts in thermoplastic material, unless otherwise specified upon ordering.

STARTUP

- verify that the instructions outlined in the INSTALLATION have been followed
- verify the correct direction of rotation (clockwise from the motor side) supplying the motor with short impulses
- ensure that the NPSH available is greater than that required by the pump (in particular for hot liquids, liquids with high vapour pressure, in presence of extension pipe with negative suction lift)
- totally flood the suction pipe (if present) and the pump
- start the pump with the discharge valve partially closed
- slowly regulate the flow by opening or closing the discharge valve (never the suction valve). Make sure that the power absorbed by the motor does not exceed the rated one indicated on the motor identification plate
- do not operate the pump at the limit values of its performance curve: maximum head (discharge valve excessively closed) or maximum capacity (total absence of drops and geodetic head on the discharge side)
- set the operating point to that for which the pump was requested
- ensure that there are no abnormal vibrations or noise due to inadequate mounting or cavitation
- avoid short and/or frequent starts by properly setting the control devices

Motor power (kW)	0,75÷1,5	2,2÷4	5,5÷7,5	11÷15	18,5÷30	37÷110
max. start/hour	: 36	28	20	15	10	6

ensure that the temperature, pressure and liquid characteristics are as those specified at the time of order.

USE

- switch automatic control on
- do not activate valves whilst the pump is in operation
- risks of dangerous water hammer effects in case of sudden or improper valve actuation (only trained personnel should operate valves)
- completely empty and wash the pump before using a different liquid
- isolate or empty the pump if the crystallization temperature of the liquid is the same or lower than the ambient temperature
- stop the pump if the liquid temperature exceeds the maximum allowed temperature indicated in the general notes; if the increase is of approximately 20%, check internal parts
- close the valves in case of leaks
- wash with water only if compatible from the chemical point of view. As alternative use an appropriate solvent that will not generate dangerous exothermal reactions
- contact the liquid supplier for information on the appropriate fire precautions
- empty the pump in case of long periods of inactivity (in particular with liquids which would easily crystallize)

MAINTENANCE

- all these maintenance operations must be performed under the supervision of qualified personnel
- make periodic inspections (2 to 30 days depending on the type of liquid and the operating conditions) cleaning filtering sections
- make periodic inspections (1 to 6 months depending on the type of liquid and the operating conditions) on the rotating parts of the pump (pump rotor); clean or replace or lubricate as necessary (see RECOMMENDATIONS)
- make periodic inspections (3 to 5 months depending on the type of liquid and the operating conditions) on the functionality of the motor control system; efficiency must be guaranteed
- excessive current consumption could be an indication of impeller problems
- unusual vibrations could be due to unbalanced impeller (due to damage or presence of foreign material obstructing its blades)
- reduced pump performance could be due to an obstruction of the impeller or damages to the motor
- motor damages could be due to abnormal friction within the pump
- damaged parts must be replaced with new original parts
- the replacement of damaged parts must be carried out in a clean dry area

DISASSEMBLY

- all these maintenance operations must be performed under supervision of qualified personnel
- cut off the power supply from the motor and disconnect the electrical wiring; pull the wires out from the terminal box and isolate their extremities accordingly
- close discharge valves
- use gloves, safety glasses and acid-proof overalls when disconnecting and washing the pump
- disconnect the piping and leave enough time for the residual liquid to exit the pump body and atmospheric air to fill the empty volume
- wash the pump before carrying out any maintenance work
- do not scatter the liquid in the environment
- lift the pump vertically avoiding to exert traction on the liner
- before attempting to dismantle the pump ensure that its motor is disconnected and that it may not be started accidentally
- now open the pump following the sequence indicated in the respective table of the LEGEND
- The nuts and bolts are right threaded.
- To access the impeller, remove the pump body unthreading the screws that fasten it to the column.
- 2) Once the pump body is open, the impeller must be disconnected, blocking the shaft on the opposite side (remove the motor fan if necessary); proceed by unscrewing the head (right thread), the impeller is then axially unthreaded.
- The shaft covering is axially unthreaded with the impeller.

To remove the column and shaft complete motor:

Remove the locking screws of the half clamps (pos.5) (fig.1)

Remove the two half clamps (pos.4) (fig.1)

Unscrew the vapour seal counterface (pos.10) keeping the column locked (fig.2)

At this point, unthread the column

At this point, proceed with the removal of the shaft (unthread the locking screws of the rigid coupling (pos. 7) or with the removal of the upper cover terminal (pos.9).

Alternatively, if it is only necessary to work on the electromotor

The disassembly of the immersed parts can be avoided (fig. 3):

Remove the locking screws of the half clamps (pos.5)

Remove the two half clamps (pos.4)

Unthread the locking screws of the rigid coupling (pos. 7)

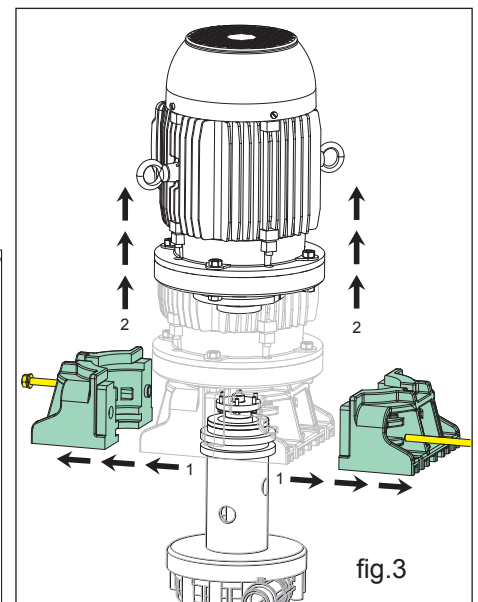
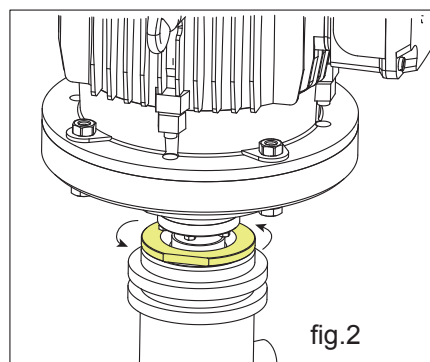
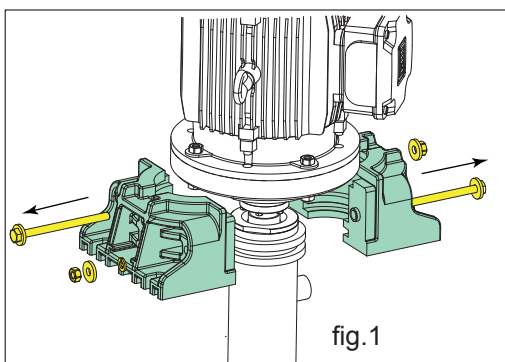

INSPECTION

Check:

- the impeller, volute and intermediate disk for abrasion and corrosion
- for lumps and clusters created by the pumped liquid (especially at the bottom of the rear chamber)
- Replace broken, cracked or deformed parts.
- Reopen all the blocked pipes and eliminate any chemical agglomeration.
- Clean all surfaces before reassembly; in particular seal rings (risk of leakage or premature wear) and O-ring seats (risk of leakage)

SAFETY RISKS

- Safety risks for personnel mainly arise from improper use or accidental damages.
- These risks may be of an electrical nature as far as the non-synchronous motor is concerned and may cause injury to hands if working on an open pump. Risks may also arise due to the nature of the liquids pumped. It is therefore of utmost importance to closely follow all the instructions contained in this manual so as to eliminate the causes that may lead to pump failure and the consequent leakage of liquid dangerous for both personnel and the environment.
- Risks may also arise from improper maintenance or dismantling practices.

In any case five general rules are important:

A - all services must be carried out by specialised personnel or supervised by qualified personnel depending on the type of maintenance required

B - install protection guards against eventual liquid sprays (when the pump is not installed in remote areas) due to an accidental pipe rupture. Arrange for safety basins to collect possible leakage

C - when working on the pump always wear acid-proof protective clothing

D - arrange for proper conditions for suction and discharge valve closing during disassembly

E - make sure that the motor is completely disconnected during disassembly.

Proper design and building of the plants, with well positioned and well marked piping fitted with shut-off valves, adequate passages and work areas for maintenance and inspections are extremely important (should the plant be faulty constructed or present wear-and-tear defects, the pressure developed by the pump could lead to failure).

It must be stressed that the major cause of pump failures leading to a consequent need to intervene is due to the pump running dry in manually operated plants. This is generally due to:

- the suction valve being open at start-up or
- the suction tank being emptied without stopping

INSTALLATION AND START-UP PERSONNEL

Interventions allowed only to specialised personnel who may eventually delegate to others some operations depending on specific evaluations (technical capability required: specialisation in industrial plumbing or electric systems as needed).

MAINTENANCE AND OPERATIONAL PERSONNEL

Interventions allowed to general operators (after training on the correct use of the plant):

pump starting and stopping

opening and closing of valves with the pump at rest

emptying and washing of the pump body via special valves and piping

cleaning of filtering elements

Interventions allowed to qualified personnel (technical capacities required: general knowledge of the mechanical, electrical and chemical features of the plant being fed by the pump and of the pump itself):

verification of environmental conditions

verification of the condition of the liquid being pumped

inspections of the control/stop devices of the pump

inspections of the rotating parts of the pump

trouble shooting

PERSONNEL RESPONSIBLE FOR REPAIRS

Interventions allowed to general operators under the supervision of qualified personnel:

stopping of the pump
closing of the valve
emptying of pump body
disconnection of piping from fittings
removal of anchoring bolts
washing with water or suitable solvent as needed
transport (after removal of electrical connections by qualified personnel)

Interventions by qualified personnel (technical capacities required: general knowledge of machining operations, awareness of possible damage to parts due to abrasion or shocks during handling, know-how of required bolt and screw tightening required on different materials such as plastics and metals, use of precision measuring instruments):
opening and closing of the pump body
removal and replacement of rotating parts

WASTE DISPOSAL

Materials: separate plastic from metal parts. Dispose of by authorized companies.

IMPROPER USE:

- The pump must not be used for purposes other than the transfer of liquids.
- The pump cannot be used to generate isostatic or counter pressures.
- The pump cannot be used to mix liquids generating an exothermal reaction
- The pump must be installed vertically on a firm structure.
- The pump must be installed on a suitable hydraulic plant with outlet connection to proper discharge pipe.
- The plant must be able to shut off the liquid flow independently from the pump.
- Handling of aggressive liquids requires specific technical knowledge

MALFUNCTIONS AND POSSIBLE CAUSES

The pump does not deliver:

- 01- wrong sense of rotation
- 02- suction piping is too long or has too many bends
- 03- pump not completely flooded
- 04- impeller blades obstructed by impurities
- 05- non-return valve on the discharge pipe blocked
- 06- the geodetic head of the plant is greater than the maximum head developed by the pump
- 07- impeller blocked by a considerable layer of crystals or by melting due to dry running

The pump has reduced capacity or insufficient pressure:

- see 01, 02, 03, 04
- 08- the head required by the plant is greater than that expected
- 09- insufficient geodetic suction head on the pump
- 10- damaged or worn impeller
- 11- viscosity of liquid greater than that expected
- 12- excessive quantities of air or gases in the liquid
- 13- excessive quantities of slurries in the liquid
- 14- bends, non-return valve or other parts close to the outlet
- 15- Liquid liable to turn to the gaseous status (particularly if hot or containing surface activ agents):
- 16- Make sure the min. suction head is reached at the inlet port
- 17- Reduce or remove the suction extension

The pump is overloaded:

- see 11, 13
- 18- capacity is higher delivery than expected
- 19- the specific weight of the liquid is greater than expected
- 20- impurities inside the pump generate abnormal friction
- 21- the power supply voltage is not the one on the motor identification plate

The pump vibrates and is noisy

- see 11, 20
- 22- the pump is working at free capacity (zero head)
- 23- the pump or piping are not firmly fixed
- 24- the supporting structure must be made more rigid

The pump shows signs of premature wear of internal parts:

- see 13, 20
- 25- liquid is excessively abrasive
- 26- frequent recurrence of cavitation (see 02, 12, 15)
- 27- high tendency of the liquid to crystallize or polymerize in stand-by
- 28- pump execution with materials not suitable for the liquid being pumped
- 29- operation at much reduced capacity

TECHNICAL DATA - IEC 50Hz

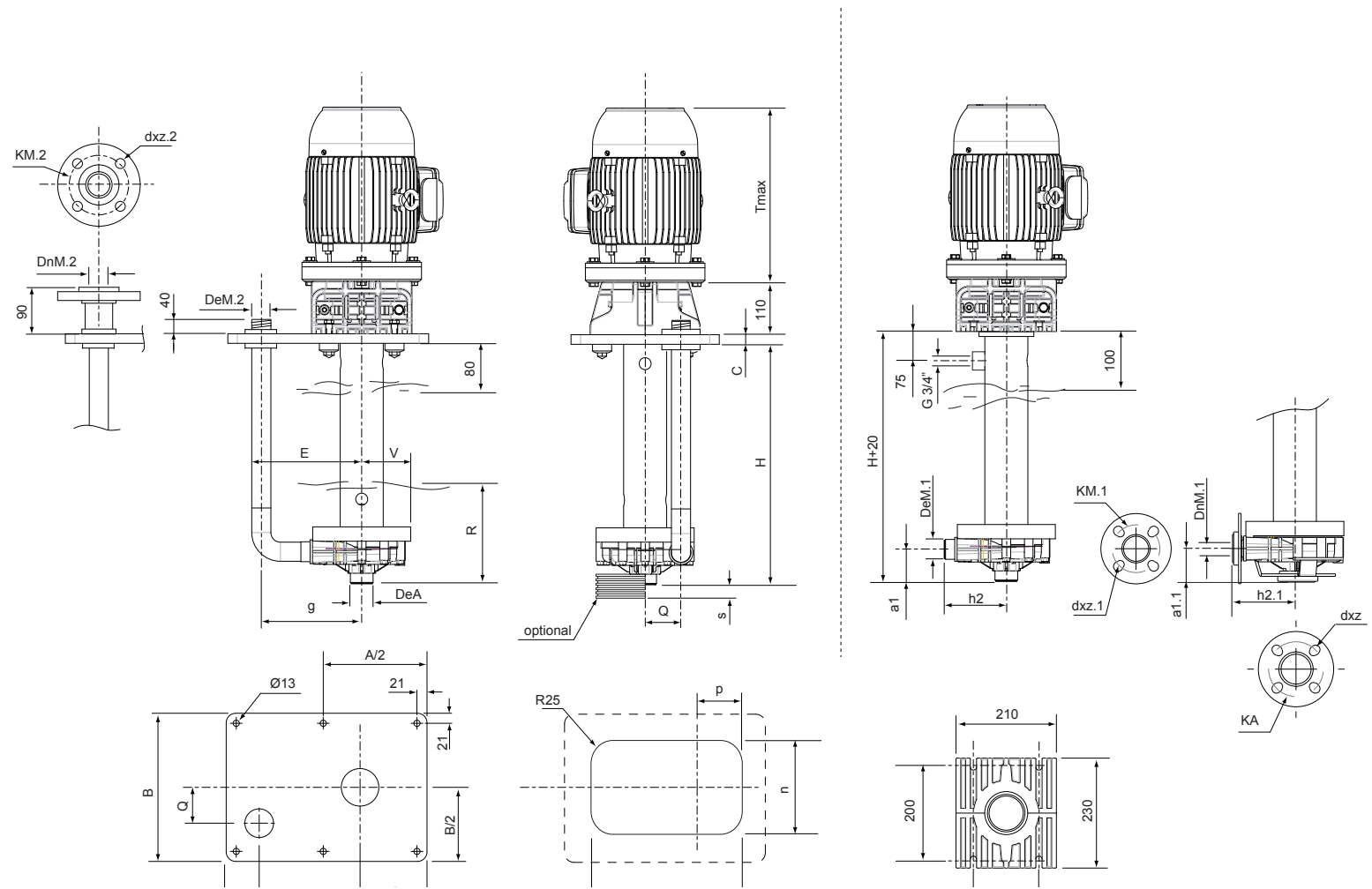

connections	Flange	04.08	06.08	06.10	10.10	10.15	16.15	16.20	20.20	20.25	30.25	30.30
DnA	ISO	25	32	32	40	40	40	40	50	50	50	50
	ANSI	1"	1" ¼	1" ¼	1" ½	1" ½	1" ½	1" ½	2"	2"	2"	2"
DnM.1	ISO	25	32	32	32	32	32	32	40	40	40	40
	ANSI	1"	1" ¼	1" ¼	1" ¼	1" ¼	1" ¼	1" ¼	1" ½	1" ½	1" ½	1" ½
DnM.2	ISO	20	20	25	25	25	32	32	40	40	40	40
	ANSI	¾"	¾"	1"	1"	1"	1" ¼	1" ¼	1" ½	1" ½	1" ½	1" ½
KA	ISO	85	100	100	110	110	110	110	125	125	125	125
	ANSI	79	89	89	98	98	98	98	121	121	121	121
KM.1	ISO	85	100	100	100	100	100	100	110	110	110	110
	ANSI	79	89	89	89	89	89	89	98	98	98	98
KM.2	ISO	75	75	85	85	85	100	100	110	110	110	110
	ANSI	70	70	79	79	79	89	89	98	98	98	98
dxz	ISO	14 x 4	18 x 4	18 x 4	18 x 4	18 x 4	18 x 4	18 x 4	18 x 4	18 x 4	18 x 4	18 x 4
	ANSI	16 x 4	16 x 4	16 x 4	16 x 4	16 x 4	16 x 4	16 x 4	19 x 4	19 x 4	19 x 4	19 x 4
dxz.1	ISO	14 x 4	18 x 4	18 x 4	18 x 4	18 x 4	18 x 4	18 x 4	18 x 4	18 x 4	18 x 4	18 x 4
	ANSI	16 x 4	16 x 4	16 x 4	16 x 4	16 x 4	16 x 4	16 x 4	16 x 4	16 x 4	16 x 4	16 x 4
dxz.2	ISO	14 x 4	14 x 4	14 x 4	14 x 4	14 x 4	18 x 4	18 x 4	18 x 4	18 x 4	18 x 4	18 x 4
	ANSI	16 x 4	16 x 4	16 x 4	16 x 4	16 x 4	16 x 4	16 x 4	16 x 4	16 x 4	16 x 4	16 x 4
	Thread	04.08	06.08	06.10	10.10	10.15	16.15	16.20	20.20	20.25	30.25	30.30
DeA	BSP / NPT	1"	1" ¼	1" ¼	1" ½	1" ½	1" ½	1" ½	2"	2"	2"	2"
DeM.1	BSP / NPT	1"	1" ¼	1" ¼	1" ¼	1" ¼	1" ¼	1" ¼	1" ½	1" ½	1" ½	1" ½
DeM.2	BSP / NPT	¾"	¾"	1"	1"	1"	1" ¼	1" ¼	1" ½	1" ½	1" ½	1" ½

size	model		IEC	a1	a1.1	h2	h2.1	Q	V	E	R min	H	A	B	C	f	g	m	n			T max (*)
G1	04.08	N	/	62	70	100	108	50	73	190	130	HME 275 - 450 KME 600 - 800 - 1000 - 1250 - 1500	400	310	20	140	170	340	250	110	25	/
		P	71A																			235
		S	71B																			255
	06.08	N	71A																			235
		P	71B																			255
		S	80A																			235
	06.10	N	71B																			235
		P	80A																			255
		S	80B																			235
G2	10.10	N	80A	67	67	130	130	75	103	222	130	HME 450 KME 600 - 800 - 1000 - 1250 - 1500	450	340	30	165	220	395	272	136	50	255
		P	80B																			300
		S	90S																			300
	10.15	N	80B																			255
		P	90S																			300
		S	90L																			330
	16.15	N	90S																			300
		P	90L																			330
		S	100																			350
	16.20	N	90L																			330
		P	100																			350
		S	112																			360
G3	20.20	N	100	70	70	160	160	96	135	252	250	HME 450 KME 600 - 800 - 1000 - 1250 - 1500	450	340	30	165	220	395	272	136	50	350
		P	112																			360
		S	132SA																			410
	20.25	N	112																			360
		P	132SA																			410
		S	132SB																			410
	30.25	N	132SA																			410
		P	132SB																			/
		S	/																			410
	30.30	N	132SB																			/
		P	/																			/
		S	/																			/

model	04.08			06.08			06.10			10.10			10.15			16.15			16.20			20.20			20.25			30.25			30.30						
	N	P	S	N	P	S	N	P	S	N	P	S	N	P	S	N	P	S	N	P	S	N	P	S	N	P	S	N	P	S							
Pump weight (rif. H600 / +100mm = 0,6 Kg)	Kg			5			5			5			6			6			6			6			10			10			10			10			
Motor weight	Kg			/	6	7	6	7	8	7	8	10	8	10	14	10	14	16	14	16	23	16	23	32	23	32	55	32	55	63	55	63	/	63	/	/	
Baseplate weight	Kg			3			3			3			3			3			3			3			3			3			3						
Max. head	mcl			10,5			10,5			12,5			14			17,5			23,5			25,5			22,5			27,5			34			40			
Max. capacity	m³/h			7			11			13,5			17,5			22			24			28			40			43			46,5			50			
Noise	dB																																				
Loads (ports-section)	Kg			Max. single strength value F(x;y;z) = 2									Max. single strength value F(x,y,z) = 2,5																								
Power	kW			/	0.37	0.55	0.37	0.55	0.75	0.55	0.75	1.1	0.75	1.1	1.5	1.1	1.5	2.2	1.5	2.2	3	2.2	3	4	3	4	5.5	4	5.5	7.5	5.5	7.5	/	7.5	/	/	
Motor frame	IEC			/	71A	71B	71A	71B	80A	71B	80A	80B	80A	80B	90S	80B	90S	90L	90S	90L	100	90L	100	112	100	112	132SA	112	132SA	132SB	132SA	132SB	132SB	/	132SB	/	/
Phase	n°			3 (all) - 1 (<3 kW)																																	
Voltage	V			400 ± 5% 50 Hz - 220 ± 5% 50 Hz																																	
Protection	IP			55																																	

TECHNICAL DATA - IEC 60Hz

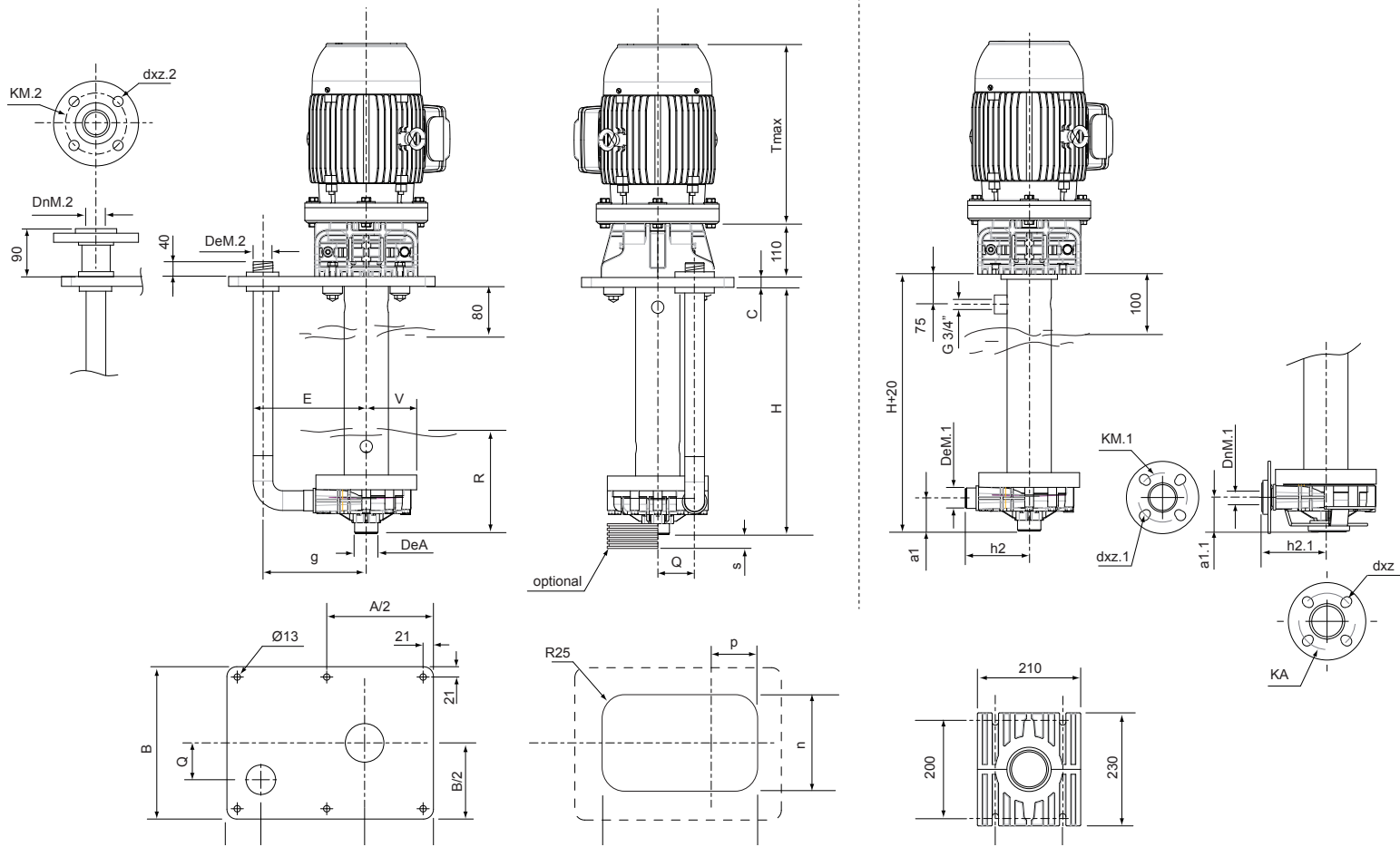

connections	flange	05.11	07.09	07.11	07.14	11.15	11.23	17.25	23.25	35.25	35.30
DnA	ISO	25	32	32	40	40	40	40	40	50	50
	ANSI	1"	1" ¼	1" ¼	1" ½	1" ½	1" ½	1" ½	1" ½	2"	2"
DnM.1	ISO	25	32	32	32	32	32	32	32	40	40
	ANSI	1"	1" ¼	1" ¼	1" ¼	1" ¼	1" ¼	1" ¼	1" ¼	1" ½	1" ½
DnM.2	ISO	20	20	25	25	25	25	32	32	40	40
	ANSI	¾"	¾"	1"	1"	1"	1"	1" ¼	1" ¼	1" ½	1" ½
KA	ISO	85	100	100	110	110	110	110	110	125	125
	ANSI	79	89	89	98	98	98	98	98	121	121
KM.1	ISO	85	100	100	100	100	100	100	100	110	110
	ANSI	79	89	89	89	89	89	89	89	98	98
KM.2	ISO	75	75	85	85	85	85	100	100	110	110
	ANSI	70	70	79	79	79	79	89	89	98	98
dxz	ISO	14 x 4	18 x 4	18 x 4	18 x 4	18 x 4	18 x 4	18 x 4	18 x 4	18 x 4	18 x 4
	ANSI	16 x 4	16 x 4	16 x 4	16 x 4	16 x 4	16 x 4	16 x 4	16 x 4	19 x 4	19 x 4
dxz.1	ISO	14 x 4	18 x 4	18 x 4	18 x 4	18 x 4	18 x 4	18 x 4	18 x 4	18 x 4	18 x 4
	ANSI	16 x 4	16 x 4	16 x 4	16 x 4	16 x 4	16 x 4	16 x 4	16 x 4	16 x 4	16 x 4
dxz.2	ISO	14 x 4	14 x 4	14 x 4	14 x 4	14 x 4	14 x 4	18 x 4	18 x 4	18 x 4	18 x 4
	ANSI	16 x 4	16 x 4	16 x 4	16 x 4	16 x 4	16 x 4	16 x 4	16 x 4	16 x 4	16 x 4
	thread	04.08	06.08	06.10	10.10	10.15	10.15	16.20	16.20	20.20	20.25
DeA	BSP / NPT	1"	1" ¼	1" ¼	1" ½	1" ½	1" ½	1" ½	1" ½	2"	2"
DeM.1	BSP / NPT	1"	1" ¼	1" ¼	1" ¼	1" ¼	1" ¼	1" ¼	1" ¼	1" ½	1" ½
DeM.2	BSP / NPT	¾"	¾"	1"	1"	1"	1"	1" ¼	1" ¼	1" ½	1" ½

size	model	IEC	a1	a1.1	h2	h2.1	Q	V	E	R min	H	A	B	C	f	g	m	n	p	s	T max (*)																																							
G1	05.11	N	71A	62	70	100	50	73	190	130	HME 275 - 450 KME 600 - 800 - 1000 - 1250 - 1500	400	310	20	140	170	340	250	110	25	235																																							
		P	71B																		255																																							
		S	80A																		235																																							
	07.09	N	71B																		67	67	130	130	75	103	222	450	KME 600 - 800 - 1000 - 1250 - 1500	340	30	165	220	395	272	136	50	25	255																					
		P	80A																																				300																					
		S	80B																																				255																					
	07.11	N	80A																																				70	70	160	160	96	135	252	250	HME 450 KME 600 - 800 - 1000 - 1250 - 1500	450	340	30	165	220	395	272	136	50	25	300		
		P	80B																																																							255		
		S	90S																																																							300		
07.14	N	80B	70	70	160	160	96	135	252	250	HME 450 KME 600 - 800 - 1000 - 1250 - 1500	450	340	30	165	220	395	272	136	50																																						25	300	
	P	90S																																																									300	
	S	90L																																																									330	
11.15	N	90S																			70	70	160	160	96	135	252	250	HME 450 KME 600 - 800 - 1000 - 1250 - 1500	450	340	30	165	220	395	272	136	50																					25	330
	P	90L																																																										330
	S	100																																																										350
11.23	N	90L																																					70	70	160	160	96	135	252	250	HME 450 KME 600 - 800 - 1000 - 1250 - 1500	450	340	30	165	220	395	272	136	50	25			330
	P	100																																																										350
	S	112																																																										360
17.25	N	112	70	70	160	160	96	135	252	250	HME 450 KME 600 - 800 - 1000 - 1250 - 1500	450	340	30	165	220	395	272	136	50																																						25		360
	P	132SA																																																										410
	S	/																																																										/
23.25	N	112																			70	70	160	160	96	135	252	250	HME 450 KME 600 - 800 - 1000 - 1250 - 1500	450	340	30	165	220	395	272	136	50																					25	360
	P	132SA																																																										410
	S	/																																																										/
35.25	N	132SA																																					70	70	160	160	96	135	252	250	HME 450 KME 600 - 800 - 1000 - 1250 - 1500	450	340	30	165	220	395	272	136	50	25			410
	P	132SB																																																										/
	S	/																																																										/
35.30	N	132SB	70	70	160	160	96	135	252	250	HME 450 KME 600 - 800 - 1000 - 1250 - 1500	450	340	30	165	220	395	272	136	50																																						25		410
	P	/																																																										/
	S	/																																																										/

model	05.11			07.09			07.11			07.14			11.15			11.23			17.25			23.25			35.25			35.30					
	N	P	S	N	P	S	N	P	S	N	P	S	N	P	S	N	P	S	N	P	S	N	P	S	N	P	S						
Pump weight (rif. H600 / +100mm ≈ 0,6 Kg)	5			5			5			6			6			6			6			10			10								
Motor weight	6	7	8	7	8	10	8	10	14	10	14	16	14	16	23	16	23	32	32	55	/	32	55	/	55	55	/	55	/	/			
Baseplate weight	3			3			3			3			3			3			3			3			3								
Max. head	18			15			15			16			21			28			35			35			35			40					
Max. capacity	8			10.5			14			18			21			24			28			40			47			50					
Noise																																	
Loads (ports-section)	Max. single strength value F(x,y,z) = 2									Max. single strength value F(x,y,z) = 2,5																							
Power	0.37	0.55	0.75	0.55	0.75	1.1	0.75	1.1	1.5	1.1	1.5	2.2	1.5	2.2	3	2.2	3	4	4	5.5	/	/	4	5.5	/	/	5.5	7.5	/	/	7.5	/	/
Motor frame	71A	71B	80A	71B	80A	80B	80A	80B	90S	80B	90S	90L	90S	90L	100	90L	100	112	112	132SA	/	/	112	132SA	/	/	132SA	132SB	132SB	132SB	/	/	/
Phase	3 (all) - 1 (<3 kW)																																
Voltage	460 ± 10% 60 Hz - 230 ± 10% 60 Hz																																
Protection	IP																																

GENERAL CONDITIONS OF SALE

1. COMPLAINTS

Complaints of any type must be made upon receiving the goods and within **one week** of discovering the defect. Complaints about incomplete orders or deterioration during transit must be made to us **immediately** and all the proofs of the irregularity must be collected in order to substantiate any claims against the carrier.

2. LONG TERM STORAGE – HORIZONTAL AND VERTICAL PUMPS

The following storage procedure is recommended for pumps that will remain idle for extended periods prior to start-up (for accessory equipment such as motors and controls, refer to the appropriate equipment manufacturer for their recommended procedures).

1. Drain pump.
2. Cover suction and discharge flanges with flange protectors and plug all the auxiliary connections to exclude dust or dirt from pump internals.
3. Coat interior and exterior of all metallic items - in contact with the external atmosphere (unpainted) - with a rust preventative.
4. Remove breather and oiler and plug tapped holes in pump power frame.
5. Cover and wrap pump with barrier film sacks (suitable for a long-term preservation of materials that need a constant environment to maintain their properties). Protect with wooden box if storage area could result in damage to pump. Indoor storage is highly recommended.
6. Rotate shaft several times at 4-6 month intervals.

3. LONG TERM STORAGE PACKAGE

Due to their unique corrosion resistant design, **ARGAL Centrifugal Pumps** require very little special preparation for long term storage (more than **four** months). Those customers who find it necessary to store centrifugal pumps for long periods of time may purchase a special Long Term Storage Package at: a nominal price. This package includes items 1, 2, 3, 4, and 5 as stated above using our standard wooden box. Cut away area on box will be noted for shaft rotation.

THIS LONG TERM STORAGE PACKAGE HAS A COST PER PUMP.

4. WARRANTY

Specifications, dimensions and any other information contained in our catalogues is to the best of our knowledge accurate. However, the above information is merely illustrative and is subject to modification without warning. In all cases we reserve the right to - at any moment - make any changes to our products that we deem to be appropriate and such changes shall not entitle the purchaser to make any claims against us. All drawings remain our exclusive property and may not be passed on to third parties or be reproduced without our written approval.

DURATION OF WARRANTY: Argal manufactures its products from first-class materials, uses qualified personnel and tests the different production stages. Within **twelve** months from the time of installation and no more than **eighteen** months from delivery Argal undertakes to examine any defective parts and to promptly replace any faulty parts free of charge if it is responsible for the fault. Such faults must not be due to wear, inexpert use or carelessness on the purchaser's part, fortuitous events or force majeure. The warranty period is shortened to **six** months if the machines work continuously twenty-four hours a day.

Even machines that are under warranty must be sent to Argal carriage paid. Once the machines have been repaired they will be returned to the purchaser carriage forward. The replaced parts remain the property of Argal and must be returned to Argal.

The warranty is voided: **1a)** if the machines have not been properly maintained; **1b)** if they have not been used in accordance with the technical standards set out in the manuals supplied with the delivery; **1c)** if the machines are dismantled without our prior authorisation; **1d)** if the machines are 'mistreated'; **1e)** if the machines are used to circulate liquids in applications that are different from those which have been specifically approved beforehand by ARGAL. We shall not be liable for the downtime arising from repairs to or the replacement of any machines of ours that are under warranty.

Argal shall not be responsible for any direct, accidental or indirect damage, injury or loss (including, but not limited to accidental or indirect damage arising from loss of profit or sales, or for any personal injury or damage arising or any other accidental or indirect loss) or for damage and injury caused by use of the machine or inability to use the machine. Before using the machine the user must check the suitability of the machine for its intended purpose and shall use the machine entirely at his own risk and responsibility.

The user notes that the pumps supplied to him by us oblige him, in accordance with Article 2050 of the Italian Civil Cod, to comply with all the legislative and regulatory standards governing dangerous activities such as using, storing and conveying aggressive and polluting chemical products.

The user also undertakes to comply with the prescriptions that apply to the system (such as guards, washers, seals etc) in which the pumps will be used and to comply with the installation instructions, checks and maintenance prescribed for pumps and installations. The user must also allow us, if necessary, to check the operating efficiency of the systems and to subsequently check that the pump has been correctly installed.

If the user fails to comply with the prescriptions laid down by us or prevents us from carrying out the above inspection, he voids all contractual warranty rights and warranty rights under the terms of Articles 1667 and 1668 of the Italian Civil Code.

NOTE: The purchase of the **ARGAL Long Term Storage Package** does not extend the standard pump warranty in any manner, i.e., **twelve** months from start-up not to exceed **eighteen** months from factory shipment. If an extension of our standard warranty is to be considered, the Long Term Storage Package must be furnished and the customer must agree to allow a ARGAL representative to inspect the equipment prior to installation and start-up. The customer shall bear the cost of this visit plus traveling expenses for the representative. As we have no control over the actual storage conditions, any repairs or repair parts required to put the equipment back in an "as new condition" shall be billed to the customer. If an extension of our standard warranty is required and if the customer is agreeable to the above conditions, contact ARGAL Division management, who has the sole authority to extend our standard warranty.

BS, 13.11.2017
ARGAL S.r.l.

Rev. 02 - 2017

WARRANTY FORM

Company: _____	
Telephone: _____	Fax: _____
Address: _____	
Country: _____	Contact Name: _____
E-mail: _____	
Delivery Date: _____	Pump was installed (date): _____
Pump type: _____	Serial no.: _____
Description of the fault: _____	

The installation	
Liquid: _____	
Temperature (°C): _____ Viscosity (cPs): _____ Spec. grav. (Kg/m ³): _____ PH-value: _____	
Contents of particles: _____ % of max size (mm): _____	
Flow (l/min): _____ Duty (h/day): _____ No. of starts per day: _____	
Discharge head (mwc): _____ Suction head/lift (m): _____	
Other: _____	

Place for sketch of the installation	

MANUFACTURER DATA



Production head and legal office:
Via Labirinto, 159 I - 25125 BRESCIA
Tel: 030 3507011 Fax: 030 3507077
Administration: Tel: 030 3507019
Sales Operation Manager: Tel: 030 3507025
Customer service: Tel: 030 3507023
Web: www.argalpumps.com
E-mail: sales.engineer@argal.it

REV. 10 - 04/18

The INSTRUCTION MANUAL must be delivered to the pump-user , who takes diligent note of it, fills in data for Maintenance Department (page 1), keeps the file for subsequent reference. Possible modifications do not imply updating of the existing manuals

© Copyright 2018 - ARGAL srl
Draw and text total or partial duplication is prohibited