

# PulsaPro®

## HYDRAULIC DIAPHRAGM METERING PUMPS



## Installation, Operation & Maintenance Manual

Bulletin: IOM-PRO-001

# PULSAFEEDER FACTORY SERVICE POLICY

Upon receipt of your new PulsaPro diaphragm metering pump, activate the warranty by registering the serial number at <http://www.pulsa.com/warranty-registration>. Should you experience a problem with your *PulsaPro* pump, go to the Pulsafeeder Service Portal to consult the troubleshooting guide in your operation and maintenance manual, refer to the frequently asked question lists, and search the Service Forum for direction and answers to solve the problem. If the issue is not covered or cannot be solved, by clicking on the Contact Us section in the Pulsafeeder Service Portal, details to connect with your local Pulsafeeder Sales Representative and our Technical Services are provided.

Parts purchased to correct a warranty issue may be credited after an examination of original parts by Pulsafeeder. Warranty parts returned as defective, which test good, will be sent back freight collect. No credit will be issued on any replacement electronic parts. If the product requires returning to the factory for inspection and/or repair, a Return Authorization Number (RMA) issued by Pulsafeeder is mandatory. To request a RMA, contact your local sales representative for an authorization form.

## TRADEMARKS

PulsaPro<sup>®</sup> is a registered trademark of Pulsafeeder, Inc.

Pulsafeeder<sup>®</sup> is a registered trademark of Pulsafeeder, Inc.

## SAFETY CONSIDERATIONS

- Read and understand all related instructions and documentation before attempting to install or maintain this equipment
- Observe all special instructions, notes, and cautions.
- Act with care and exercise good common sense and judgment during all installation, adjustment, and maintenance procedures.
- Ensure that all safety and work procedures and standards that are applicable to your company and facility are followed during the installation, maintenance, and operation of this equipment.

Copyright ©2017 Pulsafeeder, Inc. All rights reserved.

Information in this document is subject to change without notice. No part of this publication may be reproduced, stored in a retrieval system or transmitted in any form or any means electronic or mechanical, including photocopying and recording for any purpose other than the purchaser's personal use without the written permission of Pulsafeeder, Inc.

## CONVENTIONS



A WARNING DEFINES A CONDITION THAT COULD CAUSE DAMAGE TO BOTH THE EQUIPMENT AND THE PERSONNEL OPERATING IT. PAY CLOSE ATTENTION TO ANY WARNING.



NOTES ARE GENERAL INFORMATION MEANT TO MAKE OPERATING THE EQUIPMENT EASIER.

## REVISION HISTORY

Revision #	Implemented By	Revision Date	Approved By	Approval Date	Reason
0.0	M. Groth	NEW	B. Montagno	05/23/2017	New Product Line

## Table of Contents

PULSAFEEDER FACTORY SERVICE POLICY .....	1
TRADEMARKS.....	1
SAFETY CONSIDERATIONS .....	1
1. INTRODUCTION .....	5
1.1 <i>Receiving Inspection</i> .....	5
1.2 <i>General Information</i> .....	5
1.3 <i>Personnel Responsible for Pump Operation</i> .....	5
1.4 <i>Testing</i> .....	5
1.5 <i>Warranty</i> .....	5
1.6 <i>Requesting Spare Parts</i> .....	6
1.7 <i>Spare Parts</i> .....	6
1.8 <i>Liability Exclusion</i> .....	6
1.9 <i>Restrictions Regarding this Document</i> .....	6
2. TRANSPORT AND STORAGE.....	7
2.1 <i>Consignment receipt and Unpacking</i> .....	7
2.2 <i>Handling</i> .....	7
3. STORAGE INSTRUCTIONS.....	7
3.1 <i>Short Term</i> .....	7
3.2 <i>Long Term</i> .....	7
4. PRINCIPLES OF OPERATION.....	8
4.1 <i>Overall Operation</i> .....	8
4.2 <i>Nameplate Identification</i> .....	9
4.3 <i>Flow Rate</i> .....	9
4.4 <i>Intended Use</i> .....	9
4.5 <i>Components and Operation</i> .....	10
5. INSTALLATION .....	13
5.1 <i>Location</i> .....	13
5.2 <i>Piping System</i> .....	14
5.3 <i>Suction Pressure Requirements</i> .....	15
5.4 <i>Discharge Pressure Requirements</i> .....	15
5.5 <i>PULSAlarm Leak Detection Electrical Connections</i> .....	16
6. EQUIPMENT SETUP .....	17
6.1 <i>Hydraulic Oil Fill</i> .....	17
6.2 <i>PULSAlarm Leak Detection</i> .....	17
7. STARTUP PROCEDURE.....	19
7.1 <i>Output Adjustment</i> .....	19
7.2 <i>Suction System</i> .....	19
7.3 <i>Priming the Pump Head (Hydraulic System)</i> .....	19
7.4 <i>Priming the Reagent Head (Product System)</i> .....	19
7.5 <i>Calibration</i> .....	20
8. MAINTENANCE .....	21
8.1 <i>Operating Precautions</i> .....	21
8.2 <i>Consulting with Technical Documentation</i> .....	21
8.3 <i>Oil Changes</i> .....	21
8.4 <i>Wet End Removal, Inspection, and Reinstallation</i> .....	22
8.5 <i>Check Valves</i> .....	24
8.6 <i>Hydraulic Performance Valve (HPV)</i> .....	25
8.7 <i>Hydraulic Bypass Valve (HBV)</i> .....	27
8.8 <i>Push-to-Purge (PTP)</i> .....	28
8.9 <i>Piston Seal</i> .....	29

8.10	<i>Oil Seals</i> .....	29
8.11	<i>Pump Motor</i> .....	30
8.12	<i>Replacement Parts</i> .....	30
9.	<b>TROUBLESHOOTING CHART</b> .....	31
10.	<b>TECHNICAL SERVICE SUPPORT</b> .....	35
10.1	<i>Pulsafeeder Service Portal</i> .....	35
10.2	<i>Authorized Service Centers</i> .....	35
10.3	<i>Local Sales Representative</i> .....	35
10.4	<i>Factory Service Support</i> .....	35
11.	<b>APPENDIX I</b> .....	35
11.1	<i>PULSAlarm Leak Detection System</i> .....	35
11.2	<i>Leak Detection Option – Setup for Pressure</i> .....	36
11.3	<i>Pressure System Setup and Priming</i> .....	36
11.4	<i>PULSAlarm Leak Detection Diaphragm Maintenance</i> .....	38
12.	<b>APPENDIX II</b> .....	39
12.1	<i>Piping Calculations</i> .....	39
12.2	<i>System Back Pressure</i> .....	40
12.3	<i>Nomenclature</i> .....	40
13.	<b>APPENDIX III</b> .....	41
14.	<b>APPENDIX IV</b> .....	42
14.1	<i>Bolt Torque Recommendations</i> .....	42
15.	<b>APPENDIX V - ACCESSORIES</b> .....	44
15.1	<i>PULSAtrol Pulsation Dampener</i> .....	44
15.2	<i>Back Pressure Valve</i> .....	45
15.3	<i>Pressure Relief Valve</i> .....	46

# 1. INTRODUCTION



**THIS DOCUMENT CONTAINS INFORMATION TO BE USED BY QUALIFIED PERSONNEL ONLY.**

## 1.1 Receiving Inspection

All materials relative to supply are delivered to the shipper in perfect condition after thorough final testing and packaging (where applicable). Inspect goods immediately upon receipt and check:

- The goods received correspond to the order made.
- The packaging has not undergone damage due to transport or has not been tampered with.
- The actual conditions of goods.
- The presence of all accessories or spare parts.

If the packaging is damaged or tampered with, immediately check (quantity, quality, and form). If anomalies or damage are found immediately issue a complaint with the courier and inform Pulsafeeder customer support/aftermarket service.

## 1.2 General Information

The purpose of these instructions is to refer information deemed necessary for understanding as much as possible about and facilitating the installation, commissioning, use and maintenance of hydraulic diaphragm metering pumps, or PulsaPro 680, 880, 7120.

## 1.3 Personnel Responsible for Pump Operation

Personnel, before operating the pump, must be professionally trained and must have read and understood the instructions contained in this manual. The employer must instruct all staff on the risks of accidents and on devices and clothing to be used for individual safety, on the risks arising from noise emission.

### A. “Operator”

The term “Operator” is intended as personnel that carry out the following tasks on the pump:

- Performs the functions needed for operation.
- Uses the adjustment and operating commands.
- Performs simple actions related to operation.
- Performs any cleaning and daily inspection operations.
- Reports defects or pump malfunctioning.

### B. “Mechanical Maintenance”

Intended as personnel that operates on the pump in all operating conditions and at all protection levels. Performs all types of repairs or mechanical adjustments but does not work on electrical installations.

### C. “Electrical Maintenance”

Intended as personnel that operates on the pump in all operating conditions and at all protection levels. Performs all types of electrical repairs or adjustments even in the presence of voltage, if necessary.

## 1.4 Testing

Each Pulsafeeder metering pump is a reliable quality product, subject to careful final inspection to ensure their proper functioning and found compliance with the specified performance. The final test results, if specifically requested by contract, are registered and made available to the customer.

## 1.5 Warranty

PulsaPro Metering pumps, as with all other Pulsafeeder products, are guaranteed for a period of twelve (12) months of operation but in any case no longer than eighteen (18) months from the date of shipment. The guarantee covers replacement, free of charge, of any component found to be defective in material or processing by the Aftermarket Service Group at Pulsafeeder, Inc., Rochester, NY.

The warranty is NOT valid in the following cases:

- Components subject to normal wear (gaskets, seals, O-rings).
- Installation and/or use do not meet the technical conditions of sale and instructions.
- If the pump has been tampered with or disassembled.
- Motor – this is covered by the motor manufacturer.

Always avoid disassembly or attempt repairs of products still under warranty, as doing so will void the warranty. Activate the warranty on your Pulsapro pump by registering the serial number at

**<http://www.pulsa.com/warranty-registration>.**

## 1.6 Requesting Spare Parts

For Preventative Maintenance, Pulsafeeder recommends the installation of a Keep-On- Pumping kit (KOPkit), which includes the recommend spare parts needed. The KOPkit number for your pump can be found on the pump nameplate or the specification data sheet for your metering pump.

For other needed components, find and study the sectional drawing of the pump in use, if necessary contact Pulsafeeder to obtain a copy. Analyze the conditions and identify the damaged components. Using the nomenclature of the sectional drawing, make a list of the parts those components (mention the sectional drawing number and the component position code) and send to your local Pulsafeeder sales representative, always specify:

- Type of metering pump (complete model number)
- Serial number



**THIS INFORMATION CAN BE LOCATED ON THE NAMEPLATE ON YOUR METERING PUMP.**

## 1.7 Spare Parts

Modifications are not allowed. Original Pulsafeeder spare and accessories are to be used in order to assure conformity with safety rules. Pulsafeeder declines any responsibility in case of use of non-original parts and warranty will be no longer valid.

## 1.8 Liability Exclusion

Pulsafeeder is unable to monitor the observance of the instructions given in this manual, nor verify the actual working conditions and installation of the equipment, the correct operation, the using and maintenance of these machines and accessories. An incorrect installation, or misuse of the machine, may cause serious damage and may pose a danger to persons or property. Any anomalies must be reported to the maintenance supervisor. The user is not authorized to tamper with the machine for any reason.

Attempts to disassemble, modify or tamper in general by unauthorized personnel will void the warranty and will release Pulsafeeder from any liability for damage caused to persons or property resulting from such actions.

Pulsafeeder is considered released from any liability in the following case:

- Improper Installation
- Improper use of the machine by non-professional or inadequately trained operators
- Use not in compliance with regulations in the Country of use
- Lack of maintenance or improperly performed
- Use of non-original spare parts or incorrect parts for the model in question
- Total or partial failure to observe the instructions
- Exception environmental events

## 1.9 Restrictions Regarding this Document

This document is property of Pulsafeeder together with the technical information contained in it. Modification, reproduction or copying (in part or whole) without written permission is prohibited.

## **2. TRANSPORT AND STORAGE**

### **2.1 Consignment receipt and Unpacking**

Immediately after receipt of the equipment it must be checked against the delivery/shipping documents for its completeness and that there has been no damage in transportation.

Check any crate, boxes or wrappings for any accessories or spare parts that may be packed separately with the equipment or attached to side walls of the box or equipment.

Each product has a unique serial number; check that this number corresponds with that advised, and always quote this number in correspondence as well as when ordering spare parts or further accessories.

Shortages or damage should be reported immediately to the carrier and your Pulsafeeder Representative.

### **2.2 Handling**

Boxes, crates, pallets or cartons may be unloaded using fork lift vehicles or slings dependent on their size and construction.

## **3. STORAGE INSTRUCTIONS**

### **3.1 Short Term**

Storage of PulsaPro pumps for up to 12 months is considered short-term. The recommended short-term storage procedures are:

- A. Store the pump indoors at room temperature in a dry environment.
- B. Confirm or fill the eccentric box to its normal operating level with PULSA lube 6H-GS hydraulic oil. If required by the operating environment, take steps to prevent entry of water or humid air into the eccentric enclosure.
- C. Prior to start up, inspect housing, and gearbox. Replenish hydraulic oil as required to maintain operating levels. If water or condensation is present, change oil as described under Equipment Set-up.
- D. Start up in accordance with instructions in this manual.

### **3.2 Long Term**

Every twelve months, in addition to the above short-term procedures, power up the motor and operate the pump for a minimum of one hour. It is not necessary to have liquid in the reagent head during this operation, but the suction and discharge ports must be open to atmosphere. If the pump is equipped with a PULSA alarm vacuum leak detection system, ensure that a vacuum is drawn before operating the pump. See Appendix I for more information.

After twelve months of storage, Pulsafeeder's warranty cannot cover such items which are subject to deterioration with age such as seals and gaskets. If the pump has been in storage longer than 12 months it is recommended that such items be inspected and replaced as necessary prior to startup. Materials and labor to replace this class of item under this circumstance are the purchaser's responsibility. For a continuance of the warranty after extended storage, equipment inspection and any required refurbishing must be done by a Pulsafeeder representative.



## 4. PRINCIPLES OF OPERATION

### 4.1 Overall Operation

A piston reciprocates within an accurately sized cylinder at a preset stroke length, displacing an exact volume of fluid. The piston however does not pump various chemicals. The piston and associated mechanisms are enclosed in a gearbox that also serves as a hydraulic oil reservoir. A diaphragm separates the oil from the product pumped. The diaphragm moves in exact response to piston displacement. The diaphragm does no work, and acts only as a separator. Consequently, the oil displacement is translated into equal product displacement. Piston retraction causes the product to enter through the suction check valve. Piston advance causes the discharge of an equal amount of product through the discharge check valve.

Individual pumps may vary in appearance due to various liquid ends, accessories and multiplexing. The basic principles of operation however, remain the same.

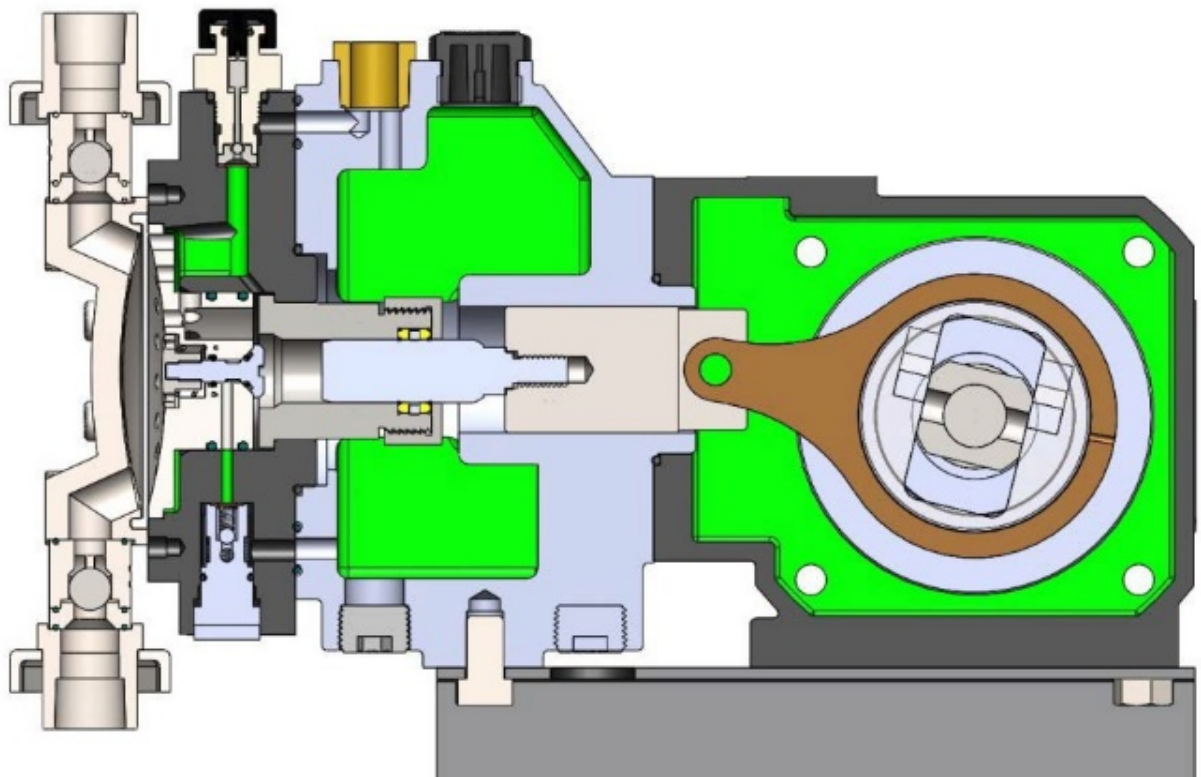

*Figure 1*

## 4.2 Nameplate Identification

Each pump carries a nameplate for identification with the following information:

- Model Series
- Serial Number
- Rated Flow
- Rated Pressure
- KOPkit Number (recommended spare parts kit)
- Piston Diameter
- Gear Ratio
- Motor Frame size, RPM rating

## 4.3 Flow Rate

PulsaPro has pulsating flow rate, generated by the alternating movement of the piston and the action of the check valves on the pump head which determine flow direction. Pump flow rate is adjustable and increases or decreases in direct proportion to the variation of the stroke adjustment.

The theoretical flow rate – corresponds exactly to the volume described by the movement of the diaphragm.

The actual flow rate – is inevitably lower than the theoretical flow rate, due to the volumetric efficiency of the pump. It varies depending on the type and size of the pump, the nature and viscosity of the liquid to be pumped, working pressure, etc.

## 4.4 Intended Use

PulsaPro 680, 880, and 7120 pumps are designed for dosing liquid fluids (flammable, acids, alkaline, solvents, etc.) at ambient temperature or heated, suitable for continuous service.

*They are used in the following markets:*

- Chemical Processing
- Petrochemical
- Oil & Gas
- Power & Energy
- Wastewater Treatment
- Potable Water Treatment
- General Industries

*Typical applications include, but are not limited to, the following:*

- Amines
- Defoamers
- Oxygen Scavengers
- Disinfectants
- Oil Additives
- Acids
- Demulsifiers
- Caustics
- Methanol
- Biocides
- Corrosion Inhibitors
- Ethylene Glycol
- Anti-Scalants
- Other Chemical Feed

## 4.5 Components and Operation

### Reagent Head

The typical reagent head assembly consists of the reagent head, diaphragm, and the suction/discharge check valves. This assembly is the only part of the pump to contact the process liquid; consequently, maintenance is critical to pump performance.

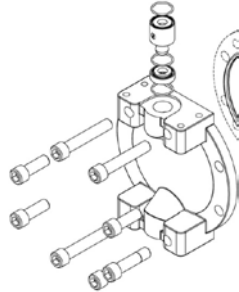

Figure 2

### Types of Diaphragms

**Flat Diaphragm** – is the standard design ensuring high performance metering in a leak-free operation. Pulsapro flat diaphragms are available in a variety of both metal and plastic materials and can handle a wide range of chemicals. As with all Pulsapro diaphragm constructions, the flat diaphragm is hydraulically balanced and operates stress free, providing exceptional life and accuracy.

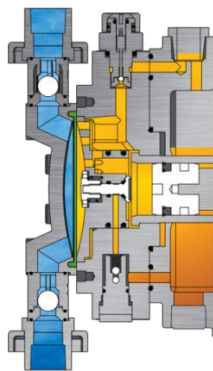

Figure 3 – Flat Diaphragm

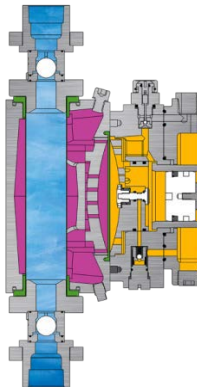

Figure 4 - HYDRAtube

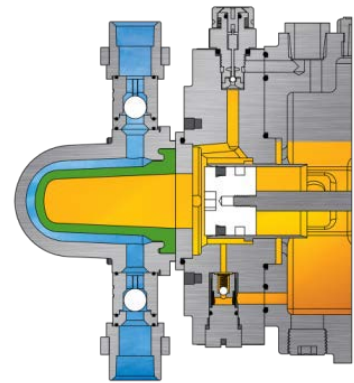
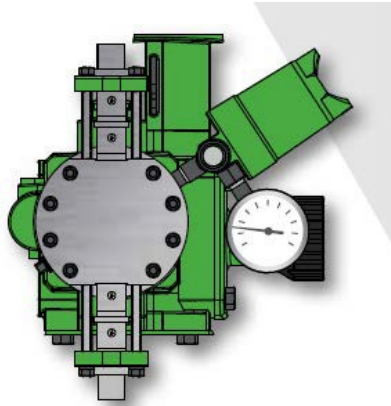

Figure 5 - HYDRAcone

**HYDRAtube** – is the best choice for sheer sensitive, high viscosity fluids and slurries. It's straight, large; flow through design eliminates clogging and flow restrictions. It offers double diaphragm safety as standard as well as optional slurry valves. Available in FKM, CSM, or PFA, it can be utilized with the most corrosive or acidic chemicals. Optional ChemAlarm leak detection system monitors the electrical conductivity of the intermediate liquid between the HYDRAtube and secondary diaphragm to detect diaphragm failure and, can signal an alarm or stop the pump.

**HYDRAcone** – self priming head features a conical elastomer diaphragm. It is particularly well suited for high-lift conditions, high viscosities, and low density slurries. It has a straight, flow through design and optional slurry valves. The HYDRAcone is available in high performance fluorocarbon elastomers.

**Double Diaphragm (Flat) with PULSAlarm Leak Detection** – offers a rugged sandwich-style double diaphragm construction for increased protection against leaks. PULSAlarm provides a pressurized leak detection technology to monitor the diaphragm integrity and can signal an alarm or stop the pump at the first sign of diaphragm failure. PULSAlarm is designed to contain full rated pressure up to 3,000 psi (207 bar), and is rated NEMA Type 7, EEMAC7 Class 1, Division 1, Groups C&D, Class 1, Zone 1, Groups IIA&IIB; UL, cUL, CE, ATEX. An optional pressure gauge is also available for visual indication of diaphragm integrity at the pump.

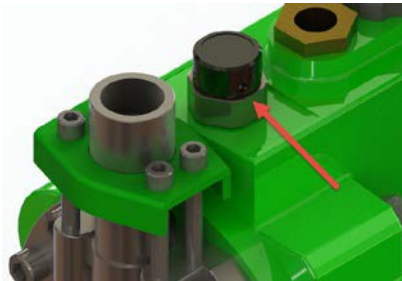

*Figure 6*

### **Pump Head/Piston Assembly**

This assembly is installed on the gearbox and consists of the pump head, cylinder, piston assembly, and three hydraulic valves (PTP, HPV, & HBV).

**PTP (Push-To-Purge)** – situated at the top of the pump head automatically removes gases from the hydraulic system during normal operation. Momentary manual actuation of the external valve button overrides automatic operation to validate priming or to determine diaphragm integrity.



*Figure 7*

**HPV (Hydraulic Performance Valve)** – automatically maintains the required hydraulic oil volume by replacing any oil lost past the piston or through the PTP valve.

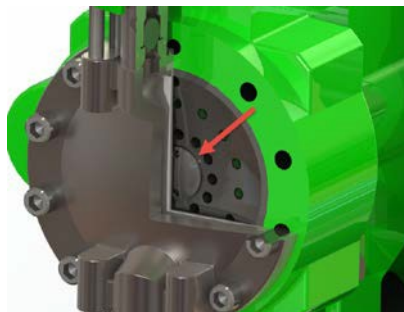

*Figure 8*

**HBV (Hydraulic Bypass Valve)** – protects the pump from over-pressurizing by relieving any excess pressure in the pump’s hydraulic system.

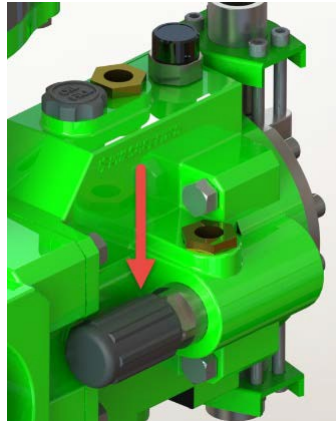

*Figure 9*

### **Manual Control Assembly**

The PulsaPro pump flow rate is adjusted by changing the stroke length on a scale from 0- 100%. The stroke is adjusted by turning the control knob, in figure 10 below, to the desired setting. The stroke length percentage is denoted by a 0-100 scale located at the top of the hand wheel. There is a locking nut used to lock the stroke in place.

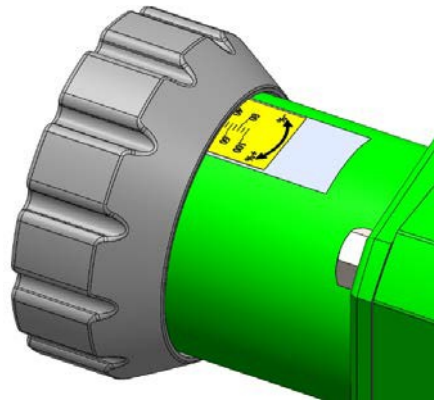

*Figure 10*

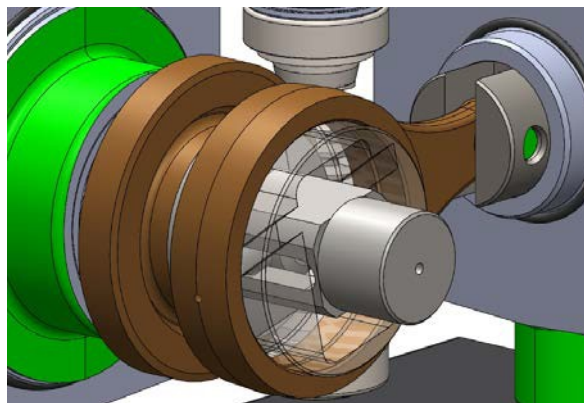

*Figure 11*

## **Gear Ratio Assembly/Motor Adaptor**

PulsaPro pumps are driven by a standard C-face electric motor mounted on the motor adaptor input flange. The motor drives a set of worm gears located in the gearbox which will then convert rotational speed into torque. They in turn power the eccentric shaft assembly that converts rotary motion into reciprocating motion. The motor adaptor is available in a variety of sizes to accommodate different motor frame specifications.

More than one pump can be driven through a single drive assembly, which is referred to as multiplexing. The pumps are mounted on a common gear reducer assembly on the drive pump and the pump without a gear reducer is called the driven pump. Each pump is mounted on its respective standard simplex base. Each pump has its own gear ratio.

Whenever pumps are multiplexed, the eccentric shafts are positioned to place a uniform load on the driver. Before full disassembly, always note the relative positions of the eccentric shafts to each other so they can reassemble in the same orientation.

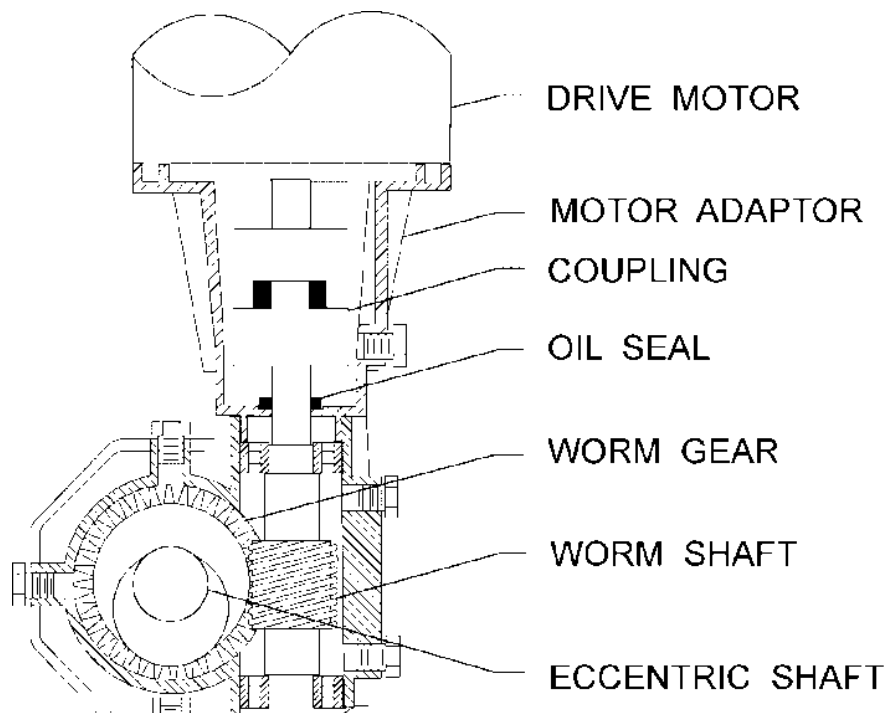

*Figure 12*

## **5. INSTALLATION**

### **5.1 Location**

When selecting an installation site or designing a skid package, consideration should be given to access for routine maintenance.

PulsaPro pumps are designed to operate indoors and outdoors, but it is desirable to provide a hood or covering for outdoor service. External heating may be required if ambient temperatures below  $-40^{\circ}\text{C}$  ( $-40^{\circ}\text{F}$ ) are anticipated. Check with the factory regarding suitability of the operating environment.

The pump must be rigidly bolted to a solid and flat foundation to minimize vibration, which can loosen connections. When the pump is bolted down, care must be taken to avoid distorting the base and affecting alignments. The pump must be level within 2 mm. This will assure that maintained at the proper levels and that the check valves can operate properly.

## 5.2 Piping System

All piping systems should include:

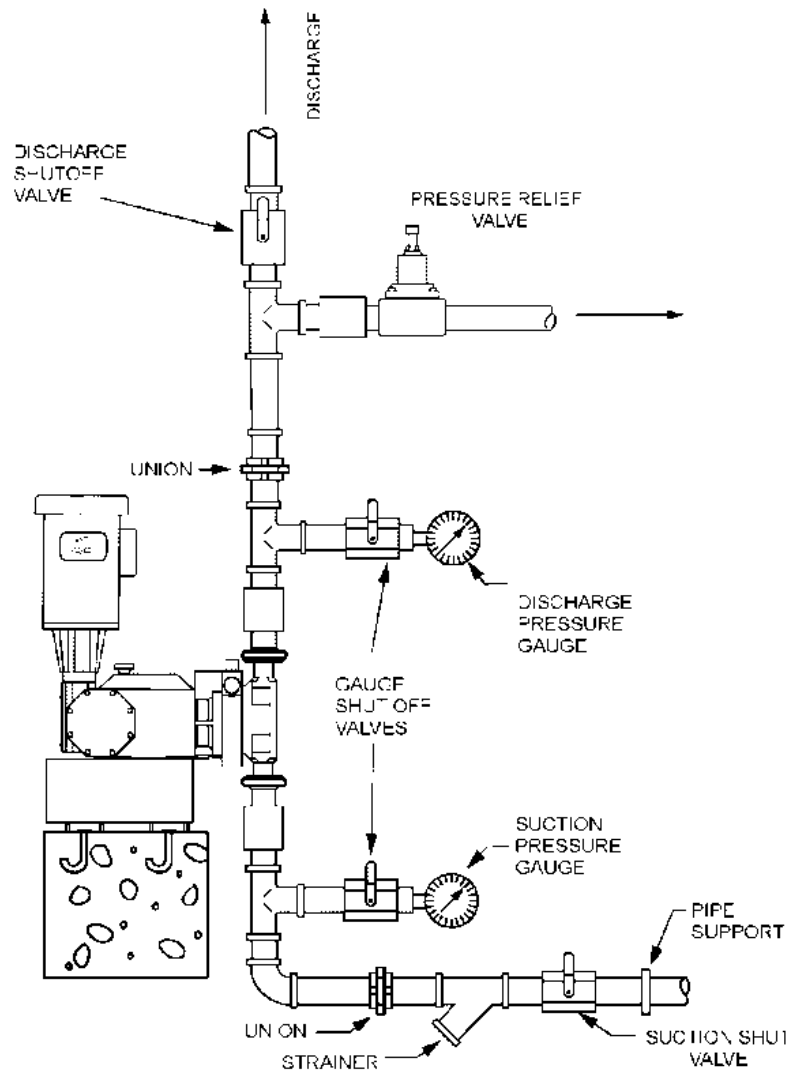

Figure 13

1. Shutoff valves and unions (or flanges) on suction and discharge piping. This permits check valve inspection without draining long runs of piping. Shutoff valves should be of the same size as connecting pipe. Ball valves are preferred since they offer minimum flow restriction.
2. An inlet strainer, if the product is not slurry. Pump check valves are susceptible to dirt and other solid contaminants unless designed for that service, and any accumulation can cause a malfunction. The strainer should be located between the suction shutoff valve and the pump suction valve. It must be sized to accommodate the flow rate and the anticipated level of contamination. 100-mesh screen is recommended.

3. Vacuum/pressure gauges in the suction and discharge lines in order to check system operation. Gauges should be fitted with protective shutoff valves for isolation while not in use.
4. A separate system relief valve to protect piping and process equipment, including the pump, from excess process pressures.



**THE HYDRAULIC BYPASS VALVE (HBV) IN THE PUMP IS NOT INTENDED TO PROTECT THE SYSTEM!**

Piping weight must not be supported by the valve housings or other portions of the reagent head, as the resulting stresses can cause leaks. If appropriate, provide for thermal expansion and contraction so that no excess force or moments are applied to the pump.

In piping assembly, use a sealing compound chemically compatible with the process material.

Users of sealing tape are cautioned to ensure that the pipe thread ends are not taped. Both new and existing piping should be cleaned, preferably by flushing with a clean liquid (compatible with process material) and blown out with air, prior to connection to the pump. Flow issues at pump startup are often related to the check valves being fouled with piping and process debris.

### 5.3 Suction Pressure Requirements

Although Pulsapro metering pumps have suction lift capability, all pump installations should have minimum lift for optimum performance. A flooded suction (i.e., suction pressure higher than atmospheric pressure) is preferable whenever possible. The pump should be located as close as possible to the suction side reservoir or other source.

Piping should be sized to allow for best possible NPIP conditions.



**IT IS NOT RECOMMENDED TO INSTALL A PUMP EQUIPPED WITH A PULSALARM LEAK DETECTION IN A SUCTION LIFT SYSTEM.**

If suction lift is required, the net positive inlet pressure required (NPIP<sub>R</sub>) is 5 psi (.35 bar). If this requirement is not met the process liquid may cavitate inside the pump, degrading metering accuracy. To maintain prime on a suction installation, a foot valve is required. In addition, suction pressure must be maintained at a minimum absolute value of 7 psi (.48 bar) to ensure proper hydraulic system and proper pump operation.



**IT IS CRITICAL THAT PULSAPRO PUMPS HAVE FREE FLOWING AND UNOBSTRUCTED SUCTION CONDITIONS AT ALL TIMES. CLOSED VALVES, CLOGGED STRAINERS, OBSTRUCTED PIPING, ETC. ARE TO BE AVOIDED. SUCTION RESTRICTIONS CAN PLACE STRESS ON THE DIAPHRAGM THAT MAY RESULT IN PREMATURE FAILURE.**

Refer to Appendix II for procedures for the calculation of suction pressure.

### 5.4 Discharge Pressure Requirements

Pulsapro Metering Pumps are designed for continuous service at the rated discharge pressure. If system suction pressure exceeds system discharge pressure, flow would be generated in addition to that caused by the pump, resulting in a reduction in accuracy and loss of control over the metering process. To prevent this condition, commonly referred to as “flow-through”, discharge pressure must exceed suction pressure by at least 5 psi (0.35 bar). The installation of a back pressure valve can achieve this if necessary to achieve the differential pressure.

Discharge systems should be protected from excessive pressures by utilizing a pressure relief or pressure limiting valve in the piping system. Operation of the pump at pressure



above its nameplate rated maximum may result in damage to the pump components and/or unsafe system conditions.

Refer to Appendix II for procedures for the calculation of discharge pressure.

## 5.5 PULSAlarm Leak Detection Electrical Connections

If equipped with an optional pressure switch, install electrical wiring and conduit in accordance with local electrical codes.

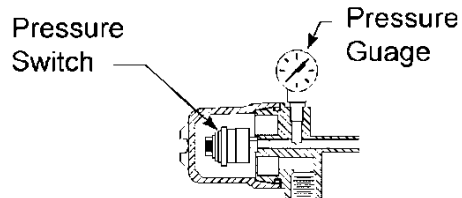

Pressure Switch Enclosure

*Figure 14*

**The switch is rated as follows:**

### **30 VDC or 125 VAC 1 Ampere Resistive**

The switch is the SPDT (single pole, double throw) type and can therefore be connected to either open or to close upon detection of diaphragm leak condition. Contacts or wires are identified as follows:

Normally Open (NO)	wire color WHITE
Normally Closed (NC)	wire color RED
Common (Com)	wire color BLACK



**THE ENCLOSURE IS LABELED WITH APPLICABLE SAFETY AGENCY RATINGS FOR HAZARDOUS AREA INSTALLATION. SINCE THE SWITCH IS OF THE MECHANICAL CONTACT TYPE, IT CAN NEVER QUALIFY AS NON-SPARKING (NON-INCENDIVE, OR "M") FOR OCCASIONAL AND SHORT-TERM HAZARDOUS AREA USE. PROTECTION MUST BE PROVIDED BY THE ENCLOSURE.**

Go to Section 11 Appendix I for further description and instructions for the PULSAlarm Leak Detection System.

## 6. EQUIPMENT SETUP

### 6.1 Oil Capacities (Dependent on piston size and internal components)

MODEL	COLOR	AMOUNT
680P	Orange	19 – 23 oz.
880P		
7120P		39 – 44 oz.

### Hydraulic Oil Fill

Remove the black oil fill cap on the pump head and gearbox to gain access to the reservoir and add PULSAlube 6H hydraulic oil. For 680P/880P models, you will fill the pump head by removing the site glass next to the PTP valve. High oil level will not affect the operation of the pump; however it can result in nuisance leakage of oil. Replace the window, making sure

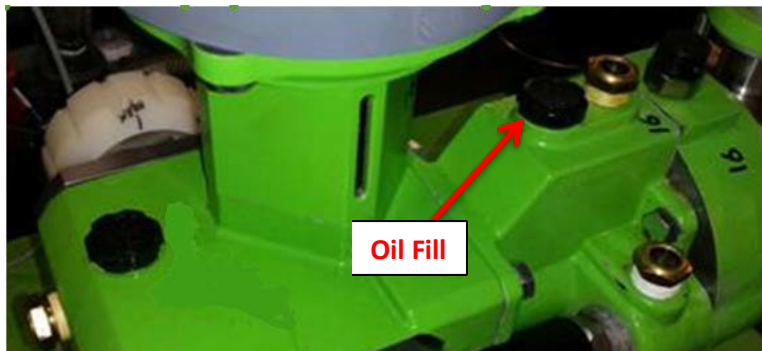

it is properly aligned and square before tightening the thumbscrew.

Figure 15

### 6.2 PULSAlarm Leak Detection



REFER TO APPENDIX I FOR STARTUP INSTRUCTIONS SPECIFIC TO PUMPS EQUIPPED WITH THE PULSALARM DIAPHRAGM LEAK DETECTION SYSTEM

### 6.3 Drive Motor Installation

#### Motor Rotation

Verification of motor direction is necessary at startup. The motor direction must be counter clockwise as is indicated on the gearbox by a directional arrow.

#### Motor Installation



Figure 16

PulsaPro pumps may be shipped with the drive motor packed separately. This is done to avoid damage during transport.

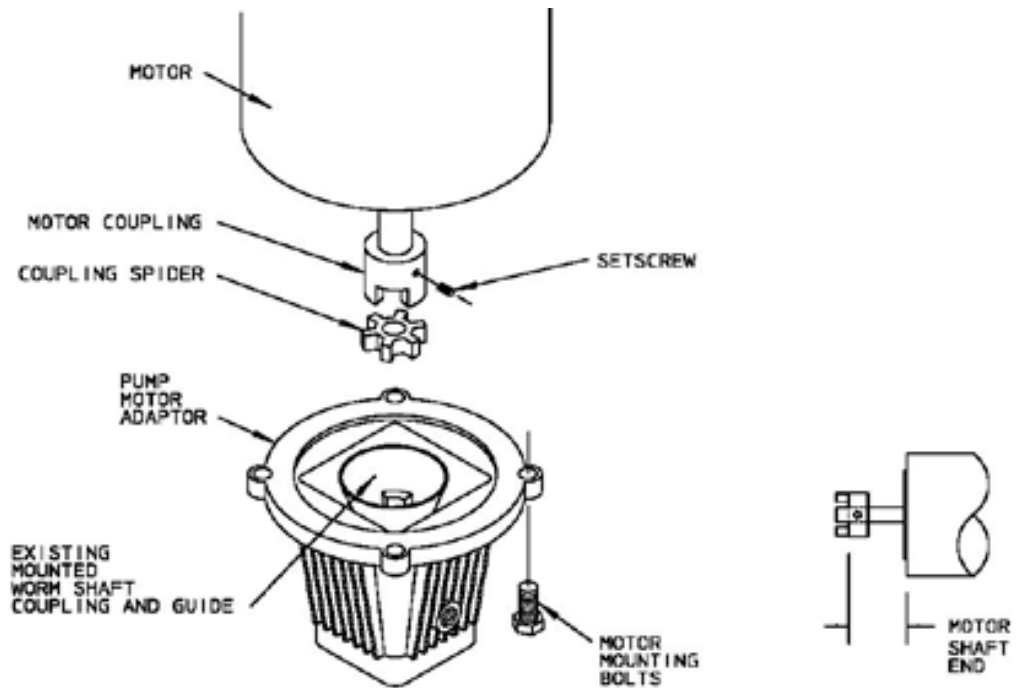

Figure 17

1. Remove the unattached coupling half from the motor adaptor. Ensure that the elastomer coupling spider remains in place, on the coupling half that remains attached to the worm shaft.
2. If applicable, remove any tape or retainer rings that hold the motor shaft key in place.
3. Place the loose coupling half on the motor shaft.
4. Tighten the setscrew onto the shaft key.
5. Place the motor in a vertical position and align the coupling teeth.
6. Install the motor downwards onto the adaptor. Final position can be achieved by slightly rotating the motor until the coupling jaws align.
7. Rotate the motor until the clearance holes in the adaptor and the tapped holes in the motor align. Fasten the motor to the adaptor using the supplied bolts (4). Tighten bolts evenly to secure motor.

## Motor Wiring

Wire the PulsaPro drive motor according to the motor vendor's nameplates and instructions, and according to any appropriate national and local electrical codes and regulations.

If the motor is to be utilized with a Pulsafeeder controller, consult the appropriate Pulsafeeder IOM for further motor wiring instructions.

## 7. STARTUP PROCEDURE

### 7.1 Output Adjustment

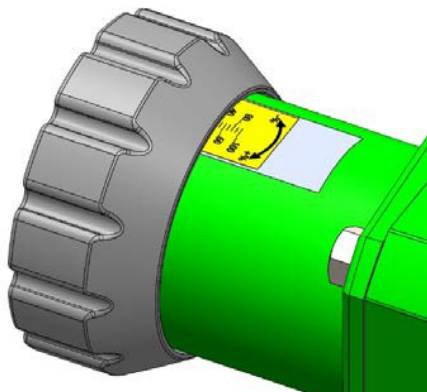

Figure 18

All Pulsapro pumps have a hand-knob for manual stroke length adjustment. Mounted on the side of the gearbox box, the hand-knob can be adjusted at any point (from 0 to 100% stroke setting) by rotating the hand wheel as required. Stroke length is locked during operation to prevent drift. Loosen the set screw to adjust the stroke rate and retighten after adjustment. The indicator adjacent to the hand-knob displays the output setting.

Adjustments can be made while the pump is at rest or operating, although operating adjustments are easier to make.



**IF THE PUMP IS EQUIPPED WITH A PRESSURE LEAK DETECTION SYSTEM, THE SYSTEM MUST REMAIN SEALED AT ALL TIMES DURING PUMP OPERATION, WHETHER OR NOT LEAK DETECTION IS REQUIRED. IF THE SEAL IS BROKEN, DECREASED FLOW AND/OR DIAPHRAGM DAMAGE WILL OCCUR. SEE APPENDIX I FOR FURTHER INFORMATION.**

**LEAK DETECTION DIAPHRAGM SYSTEMS REQUIRE SPECIAL HYDRAULIC PRIMING CONSIDERATIONS TO PROTECT THE DIAPHRAGM FROM DAMAGE DURING INITIAL PUMP STARTUP. SEE APPENDIX I FOR FURTHER INFORMATION.**

### 7.2 Suction System

Before operation of any Pulsapro pump, carefully ensure that all suction valves are in the open position. Verify that all filters and strainers are clean and clear. Ensure that any other potential causes of restriction have been addressed. Unrestricted flow of liquid to the suction side of the pump is critical to proper operation.

### 7.3 Priming the Pump Head (Hydraulic System)

All pumps are shipped with a fully primed hydraulic system. However, during shipping and handling some air may enter the hydraulic system. Generally this air will be automatically purged after a short run-in period. If necessary, rapid purging may be accomplished by fully depressing and holding the PTP valve for 5-10 seconds, while the pump is operating. Repeat as necessary until the pump stabilizes at rated flow.

See Appendix I for further information if your pump is equipped with a PULSAlarm leak detection system.

### 7.4 Priming the Reagent Head (Product System)

1. Open the suction and discharge line shutoff valves.
2. If the piping system design and the storage tank are such that the product flows due to gravity

through the pump, no priming is required. In the event the discharge line contains a significant amount of pressurized air or other gas, it may be necessary to lower the discharge pressure to enable the pump to self-prime.

3. If the installation involves a suction lift, it may be necessary to prime the reagent head and suction line. Try priming the reagent head first. Remove the discharge valve by unscrewing the four tie bar bolts and removing the valve as a unit. Fill the head through the discharge valve port with process (or compatible) liquid, then reinstall the valve and retighten the tie bar bolts.
4. Start the pump at the 0% stroke length setting and slowly increase the setting to 100% to prime the pump. If this does not work, it will be necessary to fill the suction line.
5. Filling of the suction line will necessitate the use of a foot valve or similar device at the end of the suction line so that liquid can be maintained above the reservoir level. Remove the suction valve assembly, fill the line, replace the valve, then remove the discharge valve assembly and fill the reagent head as described in Step (3) above. The pump will now self-prime when started up per step (4) above.

## 7.5 Calibration

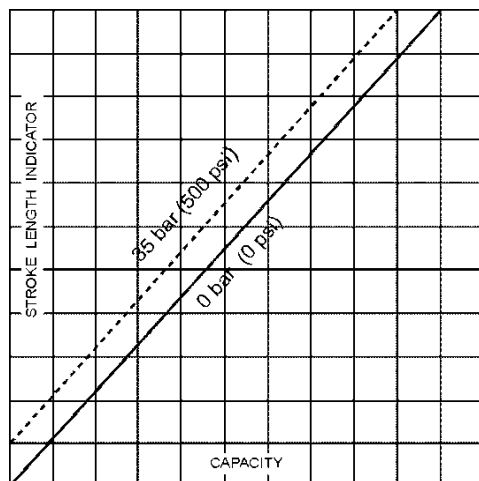

Figure 19

All metering pumps must be calibrated in order to accurately specify stroke length settings for required flow rates.

A typical calibration chart is shown in Figure 19. Although output is linear with respect to stroke length setting, an increase in discharge pressure decreases output uniformly, describing a series of parallel lines, one for each pressure (only two are shown).

The theoretical output flow rate at atmospheric output pressure is based on the displacement of the hydraulic piston (the product of piston cross-sectional area and stroke length) and the stroking rate of the pump. With increasing discharge pressure there is a corresponding decrease in output flow of approximately 1% per 7 bar (100 psig) increase in output pressure. Whenever possible, calibration should be performed under actual process conditions (i.e., the same or a similar process liquid at system operating pressure).

To assure a sound hydraulic system, run the pump for 10-15 minutes prior to calibration. This will allow the PTP (automatic bleed) valve to purge any air from the system.

To construct a calibration chart, measure the flow rate several times at three or more stroke settings (i.e., 25, 50, 75, and 100), plot these values on linear graph paper, and draw a best-fit line through the points. For stable conditions, this line should predict settings to attain required outputs.

Checking the actual flow rates is especially important in pumps producing low flow rates and operating against high discharge pressures. In this type of system, normal losses of efficiency can result in lack of measurable flow at shorter piston stroke lengths. This is a function of the system conditions and does

not indicate a problem with the pump. Careful measurement of actual pump flow at several test points will allow for proper calibration over the complete flow range.

## 8. MAINTENANCE

A metering pump is an instrument, and it is expected to perform with the precision and reliability of an instrument. It is a vital part of a system and should be subject to regular inspection, cleaning, adjustment, and replacement of worn parts. Most “emergency” shutdowns would not happen if the pump(s) were given normal maintenance care. Since the pump usually sits in a dark corner, working hour after hour, day after day, it is forgotten until the inevitable problems of chemical and mechanical wear finally catch up and product flow ceases.

Accurate records from early stages of pump operation will indicate the type and levels of required maintenance. A preventative maintenance program based on such records will minimize operational problems. It is not possible to forecast the lives of wetted parts such as diaphragms and check valves. Since corrosion rates and operational conditions affect functional material life, each metering pump must be considered according to its particular service conditions.

Each PulsaPro pump is provided with an individual specification data sheet included in the parts list package. The data sheet contains important information relating to the application along with the pump serial number and pump specifications (i.e. materials, piston size, stroking rate, etc.).

PulsaPro KOPkits (Keep-On-Pumping) contain all replacement parts normally used in preventative maintenance program. It is recommended that KOPkits and PULSAube hydraulic oil be kept available at all times. A good instruction manual, parts list, and a good maintenance record are the key to long trouble free metering pump operation.



**BEFORE PERFORMING ANY MAINTENANCE REQUIRING REAGENT HEAD OR VALVE (WET END) DISASSEMBLY, BE SURE TO RELIEVE PRESSURE FROM THE PIPING SYSTEM AND, WHERE HAZARDOUS PROCESS MATERIALS ARE INVOLVED, RENDER THE PUMP SAFE TO PERSONNEL AND THE ENVIRONMENT BY CLEANING AND CHEMICALLY NEUTRALIZING AS APPROPRIATE. WEAR PROTECTIVE CLOTHING AND EQUIPMENT AS APPROPRIATE.**

### 8.1 Operating Precautions

All operations must be performed by qualified personnel. Prior to work:

- The power line is disconnected and no parts are energized
- Any risk of accidental restart has been excluded
- Handled fluid, present in the pump head and pipelines is not pressurized
- With pump off, suction and discharge valves closed
- Pump has been adequately cleaned, when operating in aggressive chemical environments

*These maintenance suggestions are not intended as “do-it-yourself” repairs. To perform such works, specialized technical knowledge is required and operations are to be performed by qualified personnel.*

### 8.2 Consulting with Technical Documentation

Before starting work, you should consult this maintenance manual, identify the correct sectional drawing of the pump in use and get all the tools and equipment necessary to perform the maintenance or repair work.

When the pump has been disassembled, waiting to be reassembled, it is necessary to protect the various components to prevent damage caused by oxidation or accidental impact.

### 8.3 Oil Changes

The recommended oil change intervals are dependent upon the operating environment and level of

pump usage:

**Normal Service:** Clean/Dry Atmosphere, an ambient operating temperature of 0°C to 40°C (32°F to 104°F) and up to 2,000 annual operating hours.

**Severe Service:** Humid atmosphere, an ambient operating temperature below 0°C (32°F) or 40°C (104°F), and over 2,000 annual operating hours.

### Hydraulic Oil Change Procedure

1. Disconnect the power source to the drive motor.
2. Relieve all pressure from the piping system.
3. Drain the oil by removing the drain plug on the gearbox.
4. Drain the remaining oil in the pump head reservoir by remove drain plug located on bottom of pump head.
5. Remove and clean the HPV check valve screen.
6. Replace the drain plugs.
7. Fill the gearbox with PULSAlube 6H hydraulic oil. Proper fill of a fully drained pump requires 1 liter (approx. 1 quart) of PULSAlube 6H oil.

## 8.4 Wet End Removal, Inspection, and Reinstallation



**IF THE DIAPHRAGM HAS FAILED, PROCESS MATERIAL MAY HAVE CONTAMINATED THE PUMP HYDRAULIC OIL. HANDLE WITH APPROPRIATE CARE; CLEAN AND REPLACE OIL.**

### Flat Diaphragm Replacement

PulsaPro diaphragms do not have a specific cycle life; however, the accumulation of foreign material or the entrapment of sharp particles between the diaphragm and dish cavity can eventually cause failure. Failure can also occur as a result of hydraulic system malfunction or chemical attack. Periodic diaphragm inspection and replacement are recommended.

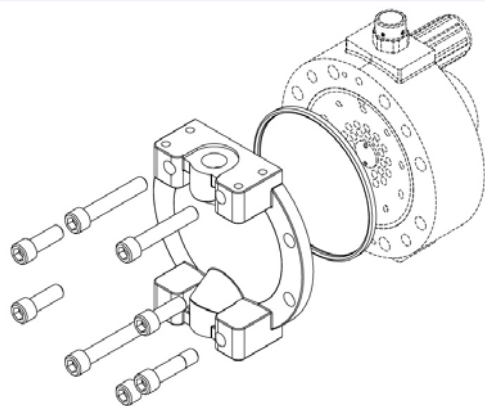

*Figure 20*

### Diaphragm Replacement Procedure

1. Disconnect the power source to the drive motor
2. Relieve all pressure from the piping system
3. Take all precautions to prevent environmental and personnel exposure to hazardous materials
4. Close the inlet and outlet shutoff valves
5. Place a suitable container underneath the pump head to catch any liquid leakage
6. Disconnect piping to the reagent head and drain process liquid, following material safety precautions described
7. Remove all but one top reagent head bolts. Oil will leak out between the pump head and reagent head as the bolts are loosened
8. Tilt the head and pour out any liquids retained by the check valves into a suitable container,

- continue to follow safety precautions as appropriate
9. Remove the final bolt and rinse or clean the reagent head with an appropriate material
  10. Remove and inspect the diaphragm. It may have taken a permanent convex/concave set as a result of normal flexure and conformance to the dish-plate. This condition is normal and is not caused for replacement. The diaphragm must be replaced if it is deformed, dimpled, or obviously damaged
  11. To install a diaphragm, first ensure that the critical sealing areas of diaphragm, reagent head, and pump head are clean and free of debris. Set the diaphragm in place on the reagent head and ensure the seat of the diaphragm sealing ring into mating groove in the reagent head
  12. Install the reagent head bolts and tighten in an alternating pattern to ensure an even seating force. Refer to torque values in torque table
  13. Re-prime the pump head



**WHEN REINSTALLING A USED DIAPHRAGM IT IS NOT NECESSARY TO MAINTAIN THE PREVIOUS ORIENTATION RELATIVE TO THE REAGENT HEAD OR PUMP HEAD PATTERN.**

### **Hydraulic Priming Procedure after Flat Diaphragm Replacement**

1. Disconnect the power source to the drive motor.
2. Relieve all pressure from piping system and where possible allow liquid to enter the reagent head assembly.
3. Remove the oil fill cap and fill the gearbox with hydraulic oil to the proper level.
4. Turn on the pump and adjust the stroke to the maximum setting of 100%.
5. Fully depress and hold the PTP valve. Continue to hold the valve down until the oil is clear of bubbles when viewing from the sight glass. The pump is now primed. If oil fails to flow out of the diagnostics port via sight glass, proceed to step 6.
6. Reset to the zero stroke length setting and turn off the pump. Adjusting the pumps stroke setting to zero will move the piston forward to prevent diaphragm damage at startup.
7. Remove the PTP valve from the pump head. Using a small plastic funnel, slowly pour oil into the pump head through the PTP valve port until full.
8. Replace the PTP valve, ensuring that the flat copper gasket and O-Ring are properly in place.
9. Turn on the pump. Gradually raise the stroke to the full 100% setting. Fully depress and hold the PTP valve. Continue to hold the valve down until the oil is clear of bubbles. If oil fails to flow out when viewing from sight glass, then additional oil is required in the pump head; repeat steps 6 and 7 above.

### **Priming of Leak Detection Diaphragm**

1. Complete re-assembly of the diaphragm, reagent head, and external components if they were taken apart. Ensure the reagent head and tie-bar bolts are tightened according to the appropriate torque specification.
2. Remove the pressure gauge from the housing body and replace it with a straight tubing adaptor fitting (also referred to as outlet side).
3. Remove the plug from the inlet side on the side of the reagent head, and install a hose adaptor fitting (also referred to as inlet side).
4. Connect a hand pump to the fitting on the outlet side of the system, and apply vacuum, which serves to pull the barrier fluid through the system.
5. Attach the incoming barrier fluid supply to the inlet side.
6. WAIT... The process will take time. Maintain vacuum on the outlet side to move the fluid through the system.
7. Observe the fluid at the outlet (vacuum pump) side. When clear, air free fluid is observed, close the inlet side needle valve.
8. Replace the plug into the needle valve to seal the system inlet.



9. Allow vacuum to remain on the outlet side of the system for approximately 2-3 minutes, this will aid in the evacuation of excess fluid. Once complete, release the vacuum and remove the hand pump.
10. Attach a short section of tubing to the fitting on the outlet side to catch excess fluid as the system setup is completed in the next steps.
11. Ensure that the pump has been filled to the appropriate level with the correct hydraulic fluid.
12. If the pump is not already hydraulically primed, re-prime it now using the appropriate procedure. If the diaphragm was never removed this step should not be necessary. If a new diaphragm is being installed, the pump will need to be re-primed.
13. In order to fully balance and evacuate the leak detection system, the pump must now run at normal discharge pressure for a period of about 30 minutes to one hour.
14. Supply either process fluid, or test fluid (i.e. water) to the suction fitting and ensure that the discharge system is configured for a safe operation. The pump can be started with minimal discharge pressure and then slowly brought up to full pressure, if the system allows for it.
15. Apply power and start the pump.
16. Slowly increase the discharge pressure to full operating pressure, and continue to run the pump.
17. During this time, excess barrier fluid will be displaced from the system into the length of tubing attached to the outlet side, balancing the system for proper operation. A small pen mark on the tube can assist in observing this process visually. Once the liquid in the tube no longer rises, the evacuation should be complete.
18. After the startup period, removing the tubing and connection from the housing body and re-install the pressure gauge. Use thread sealing tape as required.
19. Verify the connections to the alarm switch if they were disturbed during maintenance.
20. The pump and pressure leak detection system are now properly prepared and ready for normal service. During normal operation the gauge should indicate zero (0) pressure.



**UNDER CERTAIN CIRCUMSTANCES, THE SYSTEM MAY NOT COMPLETELY EVACUATE EXCESS BARRIER FLUID DURING THE PROCEDURE OUTLINED ABOVE. IN THESE CASES, AFTER SEVERAL DAYS RUN TIME, A SMALL AMOUNT OF PRESSURE MAY BUILD IN THE SYSTEM. IF THIS OCCURS, SIMPLY LOOSEN THE PRESSURE GAUGE FROM THE SWITCH HOUSING AND RELIEVE A SMALL AMOUNT OF BARRIER FLUID, RETURNING THE SYSTEM TO A ZERO-PRESSURE STATE.**

**ONCE THIS STARTUP PROCEDURE IS COMPLETED, THE PRESSURE LEAK DETECTION SYSTEM REQUIRES NO FURTHER MAINTENANCE.**

## **8.5 Check Valves**

### **Description of Check Valves**

Most fluid metering problems are related to check valves. Problems usually stem from solids accumulation between valve and seat, corrosion of seating surfaces, erosion, or physical damage due to wear or the presence of foreign objects.

The check valve incorporates a ball or disc, guide, and seat. Flow in the unchecked direction lifts the ball or disc off the seat, allowing liquid to pass through the guide. Reverse flow forces the ball or disc down, sealing it against the sharp edge of the seat. The guide permits the ball to rotate but restricts vertical and lateral movement in order to minimize “slip” or reverse flow. Ball rotation prolongs life by disturbing wear over the entire surface of the ball.

Since check return is by gravity, the valve must be in the vertical position in order to function properly. Parts are sealed by O-Rings.



Figure 21



Figure 21a

Disc valves (Figure 21a) are used in high flow application.

### Removal, Inspection, and Reinstallation

Use the following procedure to remove, inspect and reinstall the check valves:

1. Disconnect the power source to the drive motor
2. Relieve all pressure from the piping system.
3. Take all precautions to prevent environmental and personnel exposure to hazardous materials.
4. Close the inlet and outlet shutoff valves.
5. Loosen the suction valve tie-bar bolts and spring the suction piping slightly to drain any liquid from the reagent head cavity. If the piping is closely connected it may be necessary to disconnect a union or flange.
6. Remove the suction check valve assembly (ball contained within guide and seat), holding it together as a unit.
7. Loosen the tie-bar bolts on the discharge valve and spring and piping slightly to drain any liquid.
8. Remove the discharge check valve assembly, holding it together as a unit as before.
9. Disassemble both valves and examine components for wear. Seats should have sharp edges or a small chamfer, free from dents or nicks. Hold the ball firmly against its mating seat in front of a bright light to inspect for fit.

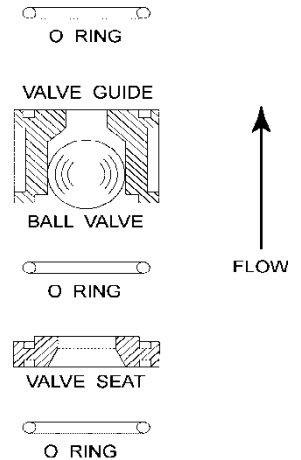

NOTE

**OBSERVATION OF LIGHT BETWEEN BALL AND SEAT IS CAUSE FOR REPLACEMENT OF EITHER OR BOTH COMPONENTS. FOR BEST RESULTS, ALWAYS LOOSEN THE UNIONS OR FLANGES ON EITHER SIDE OF THE SYSTEM PIPING PRIOR TO RE-TIGHTENING OF THE CHECK VALVE ASSEMBLIES. RE-TIGHTEN THE UNIONS OR FLANGES AFTER THE CHECK VALVES ARE SECURELY TIGHTENED INTO POSITION.**

10. Reassembly both valves using new parts as required. Sealing O-Rings should always be replaced.
11. Reinstall both valve assemblies, taking care to ensure that they are correctly orientated with balls above seats.
12. Tighten the tie-bar bolts evenly, making sure the valve assemblies are assembled squarely.
13. Torque tie-bar bolts according to the torque specification.

## 8.6 Hydraulic Performance Valve (HPV)

### General Description

PulsaPro pumps utilize the high performance valve which is integrated with the dish assembly to preserve hydraulic balance. The valve is factory preset and requires no maintenance provided the hydraulic oil remains clean. When the valve is actuated, oil is allowed to flow into the hydraulic system until the piston reaches the end of the suction stroke.

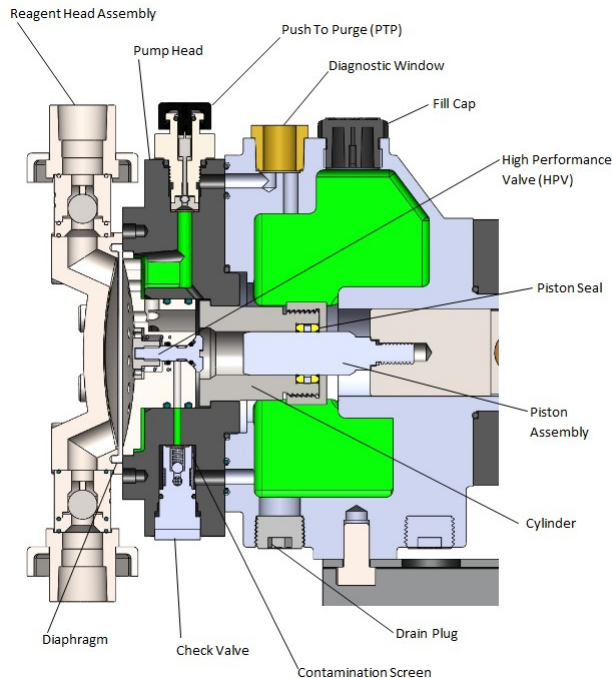

*Figure 22*

As the piston starts forward a check valve prevents oil from flowing back through the HPV, thereby allowing the valve to close as the diaphragm moves forward. Through this process the diaphragm is continually maintained in a proper operating position relative to the pump head dish-plate. Since the HPV is unaffected by the vacuum level in the pump head, oil cannot be inadvertently brought into the hydraulic system which would result in over- extension and damage to the diaphragm. This feature provides pump protection should the suction line become restricted or closed.

The check valve in series with the HPV includes a screen to trap contaminants and should be removed and cleaned with each change of hydraulic oil as indicated. A clogged filter screen will impede the operation of the HPV, and can lead to diaphragm damage. If a diaphragm has failed, and chemical has contaminated the pump head assembly, both HPV and HPV check valve should be removed and thoroughly cleaned.



*Figure 23*

### **Check Valve Screen – Removal and Cleaning**

1. Disconnect the power source to the drive motor.
2. Relieve all pressure from the piping system.
3. Drain hydraulic fluid.
4. Unscrew the check valve from the bottom of the pump.
5. Clean the valve and screen in a solvent compatible with the nitrile seal material and blow air through the valve to remove all contaminants.

6. Inspect the copper gasket and O-Ring for nicks or other damage and replace if necessary.
7. Lubricate the O-Ring with PULSAlube 6H and replace the valve, tightening securely.
8. Re-install the drain plug and refill with hydraulic oil.



*Figure 24*

### **8.7 Hydraulic Bypass Valve (HBV)**

All Pulsapro pumps incorporate a hydraulic bypass valve which is adjustable spring-loaded valve ported into the hydraulic cavity of the pump head. The valve is designed to protect the pump against excessive hydraulic pressure and will not limit or regulate system pressure. The valve is factory-adjusted for pressure as originally specified, or at 10% above the rated pump pressure.

The HBV is located on the side of the pump head and any discharge, indicating over pressurization, is visible through the diagnostic port via sight glass. If adjustments are necessary in the field, remove the valve's plastic cover and loosen the lock-nut. When turning the adjustment screw clockwise you will increase the bypass pressure, counterclockwise will decrease the bypass pressure. The locking nut must be tightened after adjustment.

Pump damage may occur during a system upset, if the hydraulic bypass pressure is set higher than 10% over the design pressure of the pump. Conversely, if the setting is too low the valve will operate on each discharge stroke. This results in decreased pumping capacity and will eventually affect the efficiency of the valve.

To check the hydraulic bypass pressure setting, install a pressure gauge and a regulating valve in the pump discharge line. The gauge must be between the pump and valve. For convenience, locate the two as close to the pump as possible. With the pump operating at maximum stroke length, gradually increase the discharge pressure and observe when the HBV starts to operate. The cracking pressure of the valve must be at least as high as the maximum pressure of the system but no more than 10% over the pumps rated pressure.

Periodic inspection of the valve seat is recommended. If it becomes worn or damaged leakage will occur.



*Figure 25*

## 8.8 Push-to-Purge (PTP)

The PTP is a gravity-operated ball check valve that automatically removes gases from the hydraulic system. On each discharge stroke of the pump, hydraulic pressure drives the ball off the lower seat, expelling any accumulation of gases at the top of the hydraulic system. An upper seat limits ball travel and flow during each actuation. On each suction stroke, the ball is pre-positioned by gravity against the lower seat to prevent reentry of gas into the system. When all gas has been expelled, a small amount of oil will be displaced on each discharge stroke. This oil is returned by gravity to the hydraulic reservoir.

Under normal operating conditions this ongoing process removes accumulations of gas long before they are visible or detrimental to pump operation. To accelerate hydraulic startup, pressing the spring-loaded button at the top of the valve holds the valve momentarily open so that large amounts of gas can be instantly purged. When the button is released, the valve reverts to normal automatic operation. PTP operation can be monitored by observing oil flow from the diagnostic port through the sight glass. Any accumulation of solids can cause the valve to malfunction.



*Figure 26*

### Removal, Cleaning, and Reinstallation

1. Disconnect the power source to the drive motor.
2. Relieve all pressure from the piping system.
3. Slowly unscrew the valve to gradually relieve any residual hydraulic system pressure.
4. Remove the valve and clean it by soaking in compatible solvent. Valve operation can be confirmed by blowing air through it in both directions and listening for the “click” sound of ball-seat contact in both directions.
5. Make sure that the copper gasket is installed at the bottom of the threaded hole in the pump head. It does not need replacement if it is sound and undamaged.
6. The elastomer gasket around the upper portion of the valve assembly may be likewise re-used.

***This valve is not repairable and must be replaced if it continues to malfunction after cleaning.***

## 8.9 Piston Seal

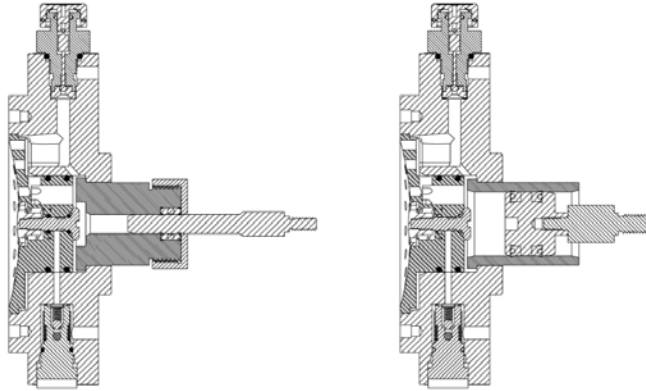

Figure 27

### General Description

PulsaPro piston seals are a thermoplastic elastomer with an FKKM energizer seal. The seal is mounted two different ways: on the piston (for larger piston sizes) or in the cylinder (for the smaller piston sizes). With oil changes at recommended intervals, piston assemblies should provide years of service.

### Removal

1. Remove the reagent head and diaphragm.
2. Remove the four bolts that secure the pump head to the eccentric box and withdraw the pump head. Take care not to lose the oval gasket and the O-Ring on the face of the eccentric box.
3. For larger piston sizes (seal installed on piston), withdraw the crosshead/piston assembly from the gearbox.
4. For smaller piston sizes (seal installed in cylinder), unscrew the seal retainingnut from the cylinder.

### Reinstallation

Reinstallation is reverse of removal. In the case of the larger piston sizes (seal installed on piston), it is important to apply an anaerobic thread-locking compound to the threads of the piston connection and the cap-screw to prevent loosening during operation. Apply PULSAlube 6H hydraulic oil to seals prior in installation to facilitate the assembly and for startup. Fill the gearbox with PULSAlube 6H hydraulic oil and prime the pump head.

## 8.10 Oil Seals

### General Description

The PulsaPro 680, 880, & 7120 have two oil seals

**Motor Adaptor Seal** – inside the motor adaptor, below the worm shaft coupling

**Stroke Adjustment Seal and O-ring** – inside of the stroke adjustment assembly

### Removal and Replacement

#### Motor Adaptor Seal:

1. Remove the four motor bolts.
2. Loosen the coupling setscrew and remove the motor and worm coupling half.
3. Remove the four motor adaptor bolts and withdraw the motor adaptor from the gearbox.
4. Using a marker, make a mark on the worm shaft nut and the gearbox.
5. Remove the worm shaft nut counting the number of turns and slide the nut and seal off of the worm shaft.
6. Remove the oil seal from the worm shaft nut.
7. Lubricate the replacement seal with PULSAlube 6H and install by pressing into position.
8. Reassemble by reversing the above disassembly procedure making sure to tighten the nut the

appropriate number of turns.

### Stroke Adjustment Seals



Figure 28



Figure 29

Figure 30



Figure 31



Figure 32

There are two seals on the stroke adjustment shaft to be replaced. An O-ring seal and an oil seal.

1. Once you have drained the pump, unscrew the stroke adjustment plug using a large screwdriver Figure 28.
2. Remove the nut from the inner shaft. Figure 29.
3. Loosen the stroke lock screw.
4. You can now unscrew and remove the adjustment shaft. Figure 31.
5. Replace the O-ring seal by sliding it off the body and install the new seal. Figure 31.
6. Remove the oil seal on the end of the adjustment shaft. You may need to carefully pry it out as it fits tightly. Figure 32.
7. Place a small amount of grease on the bearings prior to reinstalling the oil seal.
8. Place a small coat of oil on the outer surface on the new oil seal and press it into place flush with the surface, with the lip of the seal facing outward toward the gear case.
9. Reinstall the stroke adjustment shaft into the gearbox. Turn approximately 10 full rotations until the pump is at 100% stroke position. If you removed the stroke knob while installing the new seal, replace it now to assist in installing the shaft. Figure 31.
10. Retighten the stroke lock screw.
11. Reinstall the nut and tighten to about 60 Inch lbs. Figure 29.
12. Reinstall the stroke adjustment plug. Figure 28

## 8.11 Pump Motor

### Removal & Reinstallation

1. Disconnect the power source to the drive motor.
2. Disconnect the motor wiring from the motor.
3. Remove the four bolts retaining the motor to the motor adaptor and remove the motor.
4. The coupling is an interlocking jaw design and uses an elastomer spider between two coupling halves. One half of the coupling remains on the worm shaft and the other coupling half on the motor shaft.
5. Loosen the setscrew that retains the coupling half of the replacement motor, ensuring that the shaft key is in place.
6. Align the end of the shaft flush with the inner surface of the coupling and tighten the setscrew.
7. Reinstall the motor by reversing steps.

## 8.12 Replacement Parts

PulsaPro KOPkits (Keep-on-Pumping kits) contain all replacement parts normally used in a preventative maintenance program. There is a specific KOPkit for every PulsaPro pump model. Each kit is vacuum packed for extended storage. All PulsaPro pumps have the KOPkit number identified on the pump nameplate, the specification data sheet, and Pulsafeeder order documents. KOPkits can also be selected from the technical data sheet shipped with the pump or by a Pulsafeeder representative.

When ordering replacement parts always specify:

- Pump model and serial number (stamped on pump nameplate)
- Part number and description from the Parts List. (PulsaPro part numbers begin with “NP”, “MW”, or the letter “W”)

## 9. TROUBLESHOOTING CHART

ISSUE	POSSIBLE CAUSES	REMEDY
<b>Flow Rate Lower than Expected</b>	Motor Speed too low	Check voltages, frequency, wiring, and terminal connections. Check nameplates vs. specifications.
	Check Valves worn or dirty	Clean, replace if damaged
	Hydraulic bypass valve operating each stroke	Refer to <i>Hydraulic Bypass Valve</i>
	Calibration system error	Evaluate and correct
	Product Viscosity too high	Lower viscosity. Increase pump and/or piping size
	Product cavitation	Increase suction pressure
	Piston seal worn or damaged by contamination	Inspect and replace if necessary, refer to Piston Seal (Section 8 Maintenance)
	Process pressure relief valve leaking or relieving	Repair, adjust or replace
<b>Delivery gradually drops</b>	Check Valve Leakage	Clean, replace if damaged
	Leak in Suction Line	Locate and correct
	Strainer Fouled	Clean or replace screen
	Product change	Check viscosity
	Bypass leakage	Correct for bypass valve leakage
	Piston seal worn or damaged by contamination	Inspect and replace if necessary, refer to Piston seal
	Supply tank vent plugged	Unplug vent
	Coupling Disconnected	Connect Coupling



<b>Pump does not start</b>	Faulty power source	Check power source
	Blown fuse, and circuit breaker	Replace – eliminate overload
	Broken Wire	Locate and repair
	Wired Improperly	Check wiring diagram and correct
	Pipe line blockage	Open valves
<b>No Delivery</b>	Motor not running	Check power source. Check wiring diagram
	Supply tank empty	Fill tank
	Lines clogged	Clean and flush
	Closed line valves	Open valves
	Ball check valves held open with solids	Clean and inspect
	Vapor lock, cavitation	Increase suction pressure
	Prime lost	Re-prime, and check for leak
	Strainer clogged	Remove and clean, replace screen if necessary
	Hydraulic system under-primed	Re-prime the pump (Section
<b>Delivery Erratic</b>	Leak in suction line	Locate and correct
	Product cavitation	Increase suction pressure
	Entrapped air or gas in product	Ensure proper venting of system
	Motor speed erratic	Check voltage and frequency
	Fouled check valves	Clean, replace if necessary
<b>Delivery higher than rated</b>	Suction pressure higher than discharge pressure	Install backpressure valve or consult factory for piping recommendations
	Back pressure valve set too low	Increase setting
	Back pressure valve leaks	Repair, clean, or replace
	Calibration error	Review calculations
<b>Pump loses hydraulic oil</b>	Diaphragm ruptured	Replace diaphragm
	Leaky seal	Replace seal
	Cover gasket leaks	Replace or retighten

	Pump head gasket leaks	Replace – tighten pump head bolts. Apply sealing compound
	Pump head overfilled	Remove excess oil
<b>Noisy gearing/knocking</b>	Discharge pressure too high	Reduce pressure
	Water hammer	Install dampener
	Hydraulic bypass valve set too high	Readjust bypass valve
<b>Piping Noisy</b>	Pipe size too small	Increase size of piping
	Pipe runs too long	Install dampener in line
	Surge chambers flooded	Repair with air or inert gas. If dampener is installed, replace diaphragm and recharge
	No surge chambers used	Install dampener
<b>Motor Overheats</b>	Pump overloaded	Check operating conditions against pump design
	High or low voltage	Check power source
	Loose wire	Trace and correct

## DIAGNOSIS OF DIAPHRAGM FAILURE

The follow guide provides some potential causes of diaphragm failure; it is based upon visual observation of the diaphragm. This is only a guide, and may not include all potential factors.

FAILURE OBSERVED	POTENTIAL CAUSES
Puncture, surface wear, or physical damage	Abrasives or solids in the process stream Foreign object in process or hydraulic system
Extrusion and/or failure to the front (towards the process side)	Extended time under poor suction conditions, can included inadequate NPIP, closed valves, clogged strainers or filters, obstructed piping Malfunctioning High Performance Valve (HPV)
Extrusion and/or failure to the rear (towards the hydraulic side)	HPV filter screen clogged High (excessive) suction pressure Discharge pressure above maximum limit Leaking (damaged) discharge check valve
Change in surface characteristics, color	Chemical incompatibility with the process fluid

## 10. TECHNICAL SERVICE SUPPORT

### 10.1 Pulsafeeder Service Portal

The Pulsafeeder Service Portal ([svcportal.pulsa.com](http://svcportal.pulsa.com)) provides you direct access to the pump specification data sheet, IOM, parts list and troubleshooting guides.

### 10.2 Authorized Service Centers

Pulsafeeder has several Authorized Service Centers across the United States and China. Contact your local sales representative for a service center near your location.

### 10.3 Local Sales Representative

Your local Pulsafeeder Sales Representative has knowledge of Pulsafeeder Products and can provide technical service support. To locate the local sales office, in the Service Portal go to Contact Us, or go to [www.pulsa.com](http://www.pulsa.com) and open “Find a Rep or Distributor”.

### 10.4 Factory Service Support

Pulsafeeder trained technicians are available to diagnose your problem and arrange a solution. Solutions may include purchase of replacement parts or returning the unit to the factory for inspection and repair. All returns require a Return Authorization Number (RMA) issued by Pulsafeeder through your local representative. Pulsafeeder cannot accept any pump, part, or piping accessory that has pumped strong odorants (such as mercaptan).

## 11. APPENDIX I

### 11.1 PULSAlarm Leak Detection System

#### PULSAlarm Leak Detection Reagent Head Assembly

The PULSAlarm leak detection reagent head assembly consists of reagent head, leak detection diaphragm, suction and discharge check valves, vacuum bleed port, pressure switch and gauge. The reagent head, diaphragm, suction and discharge check valves are the only parts of the pump to contact the process liquid; consequently, maintenance is critical to pump performance

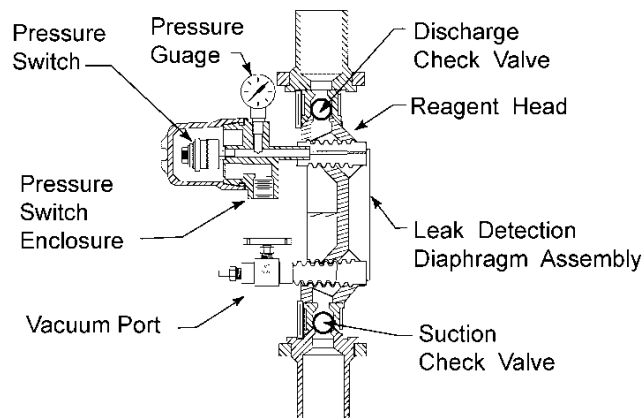

Figure 33



**A SEALED SYSTEM MUST BE MAINTAINED AT ALL TIMES DURING PUMP OPERATION, WHETHER LEAK DETECTION IS REQUIRED OR NOT. IF THE PROPER LEVEL OF VACUUM, BETWEEN 10 IN AND 26 IN (250MM AND 650MM) HG, OR A SEALED PRESSURE SYSTEM IS NOT PRESENT, DECREASED FLOW AND/OR DIAPHRAGM DAMAGE WILL OCCUR. PLEASE NOTE THAT THE**

**FACTORY SETPOINT FOR ACTUATION OF THE PRESSURE SWITCH IS 5 PSIG (.34 BAR).**

### 11.2 Leak Detection Option – Setup for Pressure

Pumps incorporating pressure leak detection are shipped from the factory with the system fully set up to work at full pump pressure. No further setup is required. The standard factory barrier fluid is silicone oil, if any other customer-specified media is used it must be compatible with construction materials. The system will require proper setup after maintenance or repairs, see Section 11.4 for the proper procedure.

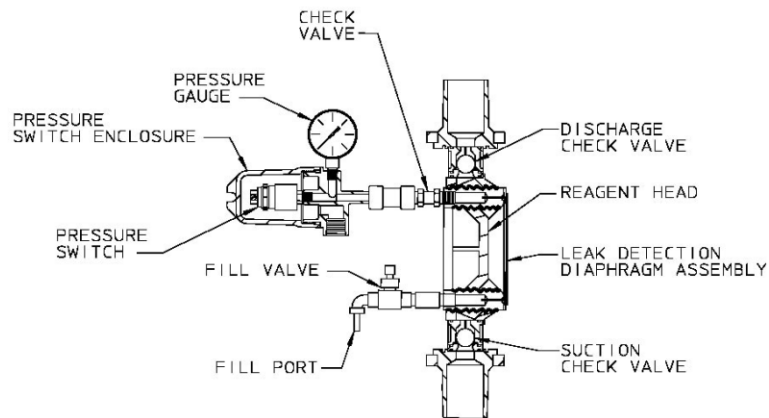

Figure 34

### 11.3 Pressure System Setup and Priming



**IF THE PRESSURIZED LEAK DETECTION SYSTEM IS OPENED TO THE ATMOSPHERE DURING MAINTENANCE OR INSPECTION, THE SYSTEM MUST BE RE-PRIMED PROPERLY TO AVOID DIAPHRAGM DAMAGE AND ENSURE PROPER LEAK DETECTION OPERATION AND SYSTEM PERFORMANCE.**



**THE STANDARD FACTORY INTERMEDIATE FLUID IS A SILICONE OIL. IF ANY OTHER CUSTOMER-SPECIFIED MEDIA IS USED, IT MUST BE COMPATIBLE WITH THE MATERIALS OF CONSTRUCTION. REFER TO THE FLUID MANUFACTURER'S LITERATURE FOR APPROPRIATE SAFETY PRECAUTIONS.**

**Use the following procedure to set-up the pressurized leak-detection system:**

1. Complete re-assembly of the diaphragm, reagent head, and external components. Ensure that reagent head and tie-bar bolts are tightened according to the appropriate torque specifications (consult Appendix IV)
2. Remove the pressure gauge from the housing body and replace with the straight tubing connection supplied with the pump or conversion kit. Connect a vacuum supply (hand vacuum pump) to the tube fitting.



**IF THE SYSTEM WAS PREVIOUSLY SEALED, YOU MAY NEED TO REMOVE THE PLUG AND RE-INSTALL THE HOSE FITTINGS AT THE FILL PORT. THERE SHOULD BE A CONTAINER IN THE VACUUM LINE TO TRAP EXCESS BARRIER FLUID. AN INEXPENSIVE AUTOMOTIVE BRAKE BLEEDING KIT IS APPROPRIATE FOR THIS PURPOSE.**

3. Connect the fill tube, supplied with the replacement diaphragm, to the fill valve tubing connection. Any short length of the appropriate sized tubing may be used for this purpose.
4. Open the fill valve.
5. Place the fill tube into a container of the barrier fluid being used.

6. Apply vacuum, the fluid should rise into the fill tube and enter the system.
7. Observe the fluid at the exit (vacuum pump) side. When clear, air free fluid is observed, close the fill valve, while maintaining the vacuum on the system to begin the process of drawing out excess fluid.



**IF YOU ARE RE-USING A PREVIOUS DIAPHRAGM, IT WILL TAKE TIME FOR THE SILICONE FLUID TO MIGRATE THROUGH THE SYSTEM, BE PATIENT!**

8. Release the vacuum, and remove both the fill tube and the vacuum pump from the fittings.
9. Empty the fill tube of fluid, and place it on the fitting near the switch, extending upwards, open to the atmosphere.
10. Ensure that the gearbox of the pump has been filled to the appropriate level with the correct hydraulic fluid.
11. Adjust the pump to the zero stroke (0%) position.
12. If the pump is not already hydraulically primed, remove the PTP valve from the top of the pump head. Using a plastic funnel or similar, slowly pour hydraulic fluid into the pump head cavity until full.
13. Inspect the PTP valve to ensure the sealing o-ring is still in position, and re-install the valve.
14. Adjust the pump to full (100%) stroke.
15. In order to fully balance and evacuate the leak detection system, the pump must now run at normal discharge pressure for a period of one hour. This ensures that excess barrier fluid is fully evacuated from the system.
16. Supply either process fluid, or test fluid (i.e. water) to the suction fitting and ensure that the discharge system is configured for safe operation. The pump can be started with minimal discharge pressure and then slowly brought up to full pressure, if the system allows for this.
17. Apply power and start the pump. Hold down the PTP valve momentarily and observe the middle port under the diagnostic cover. If no fluid is coming from this port, stop the pump and return to step 11. If fluid is present, continue to step 18.
18. Slowly increase the discharge pressure to full operating pressure, and continue to run the pump for a period of one hour.
19. During this time, excess barrier fluid will be displaced from the system into the short length of tubing attached to the exit port, balancing the system for proper operation. A small pen mark on the tube can assist in observing this process visually.
20. After the one-hour startup period, remove the tubing and connection from the housing body and reinstall the pressure gage. Remove the fitting from the fill port and replace with the supplied pipe plug.
21. Reconnect the alarm switch to the external system if necessary.
22. The pump and pressure leak-detection system are now properly prepared and ready for normal service. During normal operation, the gauge should indicate 0 (zero) pressure.



**UNDER CERTAIN CIRCUMSTANCES, THE SYSTEM MAY NOT COMPLETELY EVACUATE EXCESS BARRIER FLUID DURING THE PROCEDURE AS OUTLINED ABOVE. IN THESE CASES, AFTER SEVERAL DAYS RUN TIME, A SMALL AMOUNT OF PRESSURE MAY BUILD IN THE SYSTEM. IF THIS OCCURS, SIMPLY LOOSEN THE PRESSURE GAUGE FROM THE SWITCH HOUSING AND RELIEVE A SMALL AMOUNT OF BARRIER FLUID, RETURNING THE SYSTEM TO A ZERO-PRESSURE STATE.**

**ONCE THIS STARTUP PROCEDURE IS COMPLETED, THE PRESSURE LEAK DETECTION SYSTEM SHOULD REQUIRE NO FURTHER MAINTENANCE.**

## 11.4PULSAlarm Leak Detection Diaphragm Maintenance



**AFTER DIAPHRAGM FAILURE, PRESSURIZED PROCESS FLUID CAN BE PRESENT IN ANY PART OF THE PULSALARM LEAK DETECTION VACUUM SYSTEM. TAKE APPROPRIATE PRECAUTIONS AND HANDLE WITH CARE.**

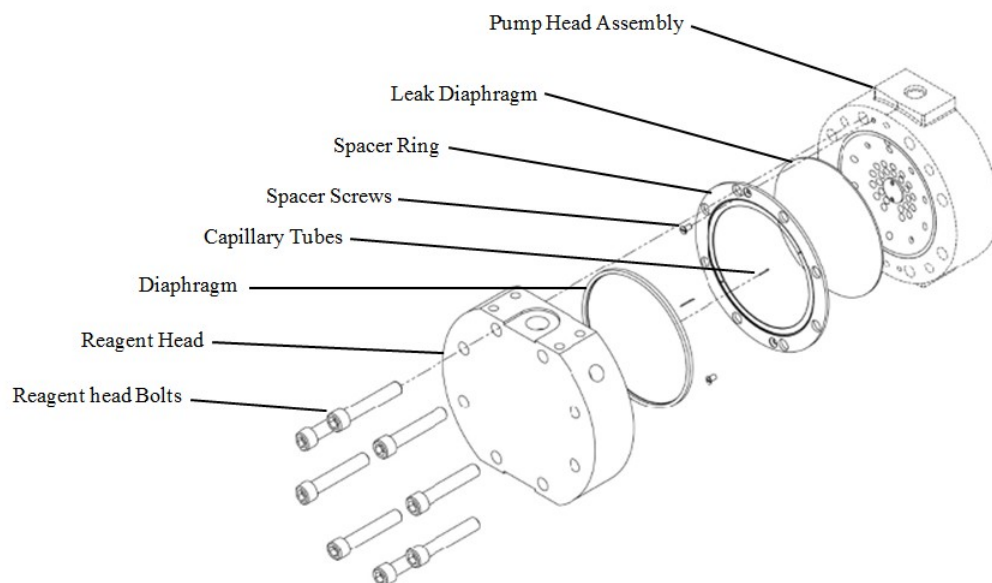

*Figure 35*

1. Ensure that the critical sealing areas of diaphragm assembly components, reagent head, and pump head are clean and free from debris.
2. Place the leak detection diaphragm onto the pump head, and set the spacer ring in place over the diaphragm.
3. Install the two screws to hold the spacer in place.
4. Align the diaphragm assembly capillary tubes with mating holes in the seal groove in the reagent head and position it in place against the reagent head. (Figure 36)

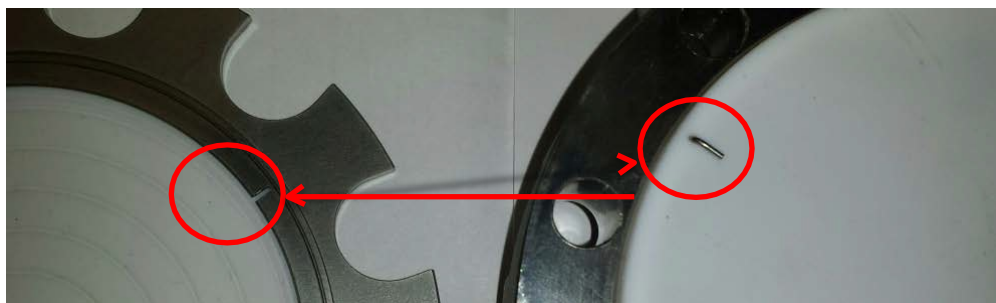

*Figure 36*



**CAUTION: MAKE SURE THAT THE CAPILLARY TUBES ARE PROPERLY ALIGNED WITH THE OPEN SLOTS IN THE SPACER RING PRIOR TO INSTALLING THE REAGENT HEAD SO THAT YOU DON'T CRUSH THE TUBES. (FIGURE 6)**

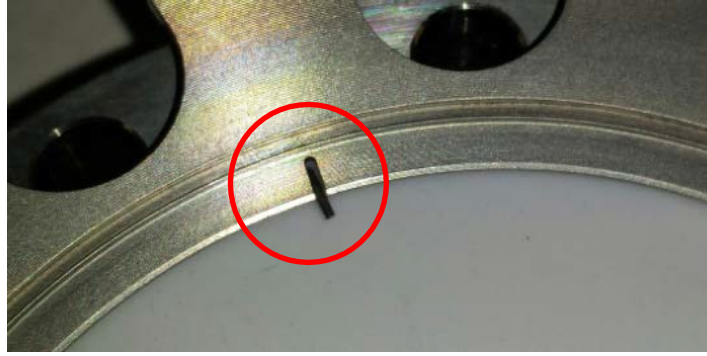

Figure 37

5. Place the reagent head onto the pump head and install the reagent head bolts. Tighten in an alternating pattern to ensure an even seating force.
6. Torque the reagent head bolts to the values found in Appendix IV, Bold Torque Specifications.
7. Re-prime the pump per the procedure outlined in Section 11.3, Pressure System Setup and Priming.

## 12. APPENDIX II

### 12.1 Piping Calculations

#### Suction Head Requirements

All reciprocating metering pumps require a net positive suction head (NPIP<sub>R</sub>). Refer to Table 1 for the (NPIP<sub>R</sub>) required for PULSAPRO pump models. The NPIP<sub>R</sub> is defined as the pressure required above the absolute vapor pressure of the process fluid at the pumping temperature. This pressure is required at the suction port of the pump throughout the entire pump stroking cycle in order to prevent cavitation of the process fluid within the reagent head. The NPIP<sub>R</sub> is one of the requirements necessary to assure metering accuracy.

NPIP <sub>R</sub>	PULSAPRO
English (psi)	5
Metric (bar)	0.34

Table 1- NPIP<sub>R</sub> values

The net positive suction head available (NPIP<sub>A</sub>) must be greater than the NPIP<sub>R</sub>. The NPIP<sub>A</sub> of any given system is calculated as follows for comparison to the NPIP<sub>R</sub> as shown in Table 1.

*Equation #1 – For fluid viscosity below 50 centipoise*

$$NPIP_A = P_A \pm P_H - P_V - \left( \frac{L_s R G Q}{C_1 d^2} \right)$$

*Equation #2 – For fluid viscosity above 50 centipoise*

$$NPIP_A = P_A \pm P_H - P_V - \sqrt{\left( \frac{L_s R G Q}{C_1 d^2} \right)^2 + \left( \frac{L_s \mu Q}{C_2 d^4} \right)^2}$$

Refer to Section 12.3 Nomenclature, for the definitions of variables used in the equations above; follow the units shown in Table 3b for the constants listed to be used correctly.





**IF PIPING SIZES VARY THROUGHOUT THE SUCTION LINE, DIFFERENT ADDITIVE VALUES MAY BE USED FOR THE PRESSURE LOSSES ATTRIBUTED TO THE LIQUID'S ACCELERATION AND DECELERATION. USE THE LAST TERM OF EQUATION 1 OR 2 AS MANY TIMES AS NEEDED IN THE EQUATION TO ADJUST FOR DIFFERENT LENGTHS OF DIFFERENT PIPE DIAMETERS IN THE SUCTION LINE. (EVERYTHING BUT THE PIPE LENGTH AND DIAMETER WILL STAY THE SAME IN THE EQUATION.)**

All reciprocating metering pumps also require that a minimum absolute pressure and minimum suction head (msh), be maintained at the pump inlet throughout the pumping cycle to ensure a stable hydraulic system and proper pump operation. The sum of the nps<sub>h</sub>a and the vapor pressure (p<sub>v</sub>) must be greater than the values shown in table 2.

MSP	PULSAPRO
English, (psia)	7.5
Metric, (bar(a))	0.53

Table 2 - Minimum values for the sum of NPIPA and vapor pressure. (MSP)

## 12.2 System Back Pressure

The system backpressure must exceed the suction pressure by at least 5 psi (0.35 bar) in order to prevent flow through, however it must not exceed the rated discharge pressure of the pump. Flow through can be defined as the process liquid flowing from a higher pressure to a lower pressure (downhill pumping), which attributes to pump failure and undesired flow at pump shutdown. If the system backpressure is not at least 5 psi (0.35 bar) greater than the suction pressure, a backpressure valve must be installed in the discharge piping. To calculate the system's total backpressure use Equation 3 or 4.

**Equation #3 – For fluid viscosity below 50 centipoise.**

$$P_T = \left( \frac{L_s R G Q}{C_1 d^2} \right) + P_P \pm P_H$$

**Equation #4 – For fluid viscosity above 50 centipoise.**

$$P_T = \sqrt{\left( \frac{L_s R G Q}{C_1 d^2} \right)^2 + \left( \frac{L_s \mu Q}{C_2 d^4} \right)^2} + P_P \pm P_H$$

## 12.3 Nomenclature

NPIPR	Net positive inlet pressure required, [psi, bar]
NPIPA	Net positive inlet pressure available, [psi, bar]
PA	Pressure at the surface of the liquid being pumped (atmospheric or supply tank blanket pressure) [psi(a), bar(a)]
PH	Head pressure above (+) or below (-) the pump centerline, [psi, bar,] (convert from ft or m)

PV	Absolute vapor pressure at pumping temperature of the process liquid at pump inlet, [psi(a), bar(a)]
LS	Length of suction piping (actual, not equivalent), [ft, m]
R	Pump stroking rate, strokes/min [spm]
G	Specific gravity of process liquid, [no units]
Q	Pump average flow rate, [gph, lph]
d	Internal pipe diameter, [inches, mm]
C1, C2, C3	Numeric constants used in Equations 1 - 4 [no units] see table 2 for values
$\mu$	Viscosity of process liquid at pumping temperature, centipoise [cp]
LD	Length of discharge piping (actual, not equivalent), [ft, m]
PP	System discharge pressure, [psi(g), bar(g)]
PT	Peak pump discharge pressure at the discharge port, [psi(g), bar(g)]
VP	Peak liquid velocity generated by the pump, (suction or discharge) [ft/s, m/s]

*Table 3a – Definitions of abbreviations used in NPIP Equations*

Variable	Units Set	
	English	Metric
NPIP	psi	bar
PA	psia	bar(a)
PH	psi	bar
PV	psia	bar(a)
LS	feet	meters
R	strokes/min	strokes/min
G	no units	no units
Q	gallons/hr	liters/hr
d	inches	millimeters
$\mu$	centipoise	centipoise
LD	feet	Meters
PT	psi	bar
PP	psi	bar
VP	feet/sec	meters/sec
C1	24,600	640
C2	45,700	1.84
C3	46.8	0.91

*Table 3b - Unit sets and constant values for use in NPIP Equations*

## 13. APPENDIX III

### 12.4 Oil Specifications

#### PULSAIube 6H

#### IMPORTANT HEALTH, SAFETY, AND ENVIRONMENTAL INFORMATION

Relative Density (at 15 °C):	0.86
Flammability (Solid, Gas):	N/A
Flash Point [Method]:	>210°C (410°F) [ASTM D-92]
Flammable Limits (Approx. volume % in air):	LEL: 0.9 UEL: 7.0 Autoignition
Temperature:	N/D

Boiling Point / Range:	> 316°C (600°F)
Decomposition Temperature:	N/D
Vapor Density (Air = 1):	> 2 at 101 kPa
Vapor Pressure:	< 0.013 kPa (0.1 mm Hg) at 20 °C
Evaporation Rate (n-butyl acetate = 1):	N/D

## 14. APPENDIX IV

### 14.1 Bolt Torque Recommendations

#### FOR MODELS WITH METAL HEADS AND PTFE DIAPHRAGM <sup>(1)</sup>

REAGENT HEAD BOLTS				TIE BAR BOLTS		
Reagent Head #	# Bolts and Thread Size	Torque <sup>(2)</sup>		# Bolts and Thread Size	Torque <sup>(2)</sup>	
		FT-LBS	N-M		IN-LBS	N-M
MW16000 7	8 * 3/8-16	11.3	15.3	4 * 1/4-20	12.2	1.4
MW16000 14	8 * 3/8-16	11.3	15.3	4 * 1/4-20	12.2	1.4
MW16000 2	8 * 5/16-18	5.8	7.9	4 * 1/4-20	12.2	1.4
MW16000 3	8 * 7/16-14	18.2	24.7	4 * 5/16-18	29.7	3.4
MW16000 4	86 * 1/2-13	23.7	32.1	4 * 1/2-13	49.0	5.5
W201544	8 * 5/16-18	5.8	7.9	2 * 1/4-20	12.2	1.4
W203344	12 * 1/2-13	21.7	29.4	2 * 5/16-18	50.7	5.7
W205343	12 * 5/8-11	41.4	56.1	2 * 5/16-18	81.0	9.2
W201983	8 * 3/8-16	11.3	15.3	2 * 5/16-18	29.7	3.4
W205699	8 * 1/2-13	21.0	28.5	3 * 3/8-16	49.7	5.6
W203017	10 * 3/4-10	100.8	136.7	2 * 1/2-13	265.0	30.0
W202420	6 * 1/2-13	23.7	32.1	2 * 1/2-13	49.0	5.5
W209786	6 * 1/2-13	23.7	32.1	2 * 1/2-13	140.3	15.9
W204938	12 * 5/8-11	50.8	68.9	2 * 1/2-13	168.0	19.0
W203806	6 * 3/4-10	89.7	121.6	2 * 1/2-13	180.4	20.4
W205341	6 * 3/4-10	38.2	51.8	2 * 1/2-13	48.1	5.4

#### FOR MODELS WITH METAL HEADS AND METAL DIAPHRAGM <sup>(1)</sup>

REAGENT HEAD BOLTS				TIE BAR BOLTS		
Reagent Head#	# Bolts and Thread Size	Torque <sup>(2)</sup>		# Bolts and Thread Size	Torque <sup>(2)</sup>	
		FT-LBS	N-M		IN-LBS	N-M
W204524	6 * 3/8-16	8.3	11.3	2* 1/4-20	12.2	1.4
W204335	12 * 1/2-13	18.4	25.0	2 * 5/16-18	50.7	5.7
W208287	12*5/8-11	34.4	46.1	2 * 5/16-18	76.0	8.6

W205117	8 * 7/8-9	120.4	163.2	2 * 3/8-16	152.2	17.2
W204537	6 * 1/2-13	17.2	23.3	2 * 1/4-20	7.1	0.8
W204331	8 * 3/4-10	49.8	67.5	3 * 3/8-16	27.4	3.1
W205505	8 * 1-1/8-7	249.0	337.6	2 * 1/2-13	121.8	13.8
W205011	10 * 1-1/4-7	369.0	500.3	2 * 1/2-13	203.0	22.9
W204241	8 * 1/2-13	27.7	37.6	2 * 1/2-13	26.9	3.0
W205799	12 * 3/4-10	68.1	92.3	2 * 1/2-13	66.3	7.5
W205533	10 * 1-1/8-7	217.6	295.0	2 * 1/2-13	117.6	13.3
W205144	10 * 1-1/2-6	653.9	886.6	2 * 1/2-13	265.0	29.9
W205631	8 * 3/4-10	73.8	100.0	2 * 1/2-13	49.0	5.5
W205137	12 * 1-1/4-7	281.0	381.0	2 * 3/4-10	252.0	28.5
W206986	8 * 3/4-10	77.4	104.9	2 * 1/2-13	80.2	9.1
W207481	8 * 1-1/4-7	290.1	393.3	2 * 1/2-13	180.4	20.4

1. Reagent heads in these categories can be referenced by the head # which is stamped or cast on the part.
2. Torque values are for Grade 8, Carbon Steel Socket Head Cap screws only, with lubricated threads.

#### FOR MODELS WITH PTFE/PVC HEADS AND PTFE DIAPHRAGM <sup>(1)</sup>

REAGENT HEAD BOLTS				TIE BAR BOLTS		
Reagent Head#	# Bolts and Thread Size	Torque <sup>(2)</sup>		# Bolts and Thread Size	Torque <sup>(2)</sup>	
		FT-LBS	N-M		IN-LBS	N-M
W204374	8*5/16-18	1.5	2.0	2 * 1/4-20	3.0	0.3
W203668	4.3/8-16	5.9	8.0	2 * 3/8-16	9.3	1.1
W204785	6 * 1/2-13	10.2	13.8	2. 1/2-13	21.0	2.4
W209925	6. 1/2-13	8.8	11.9	4 * 3/8-16	17.8	2.0
W204008	6*3/4-10	29.9	40.5	2 * 5/8-11	68.0	7.7
W204829	6 * 3/4-10	47.7	64.7	2 * 1/2-13	90.6	10.2

#### FOR MODELS WITH HYDRATUBE HEAD AND METAL VALVES <sup>(1)</sup>

REAGENT HEAD BOLTS				TIE BAR BOLTS		
Reagent Head#	# Bolts and Thread Size	Torque <sup>(2)</sup>		# Bolts and Thread Size	Torque <sup>(2)</sup>	
		FT-LBS	N-M		IN-LBS	N-M
W094147	8 * 5/16-18	5.8	7.9	2 • 5/16-18	15.2	1.7
W094544	4 * 3/8-16	9.8	13.3	2 * 3/8-16	15.5	1.8
W094689	4 * 1/2-13	22.9	31.0	2 * 1/2-13	52.1	5.9
W096319	4 * 3/4-10	67.3	91.2	2 * 1/2-13	90.2	10.2

#### FOR MODELS WITH HYDRATUBE HEAD AND PTFE VALVES <sup>(1)</sup>

REAGENT HEAD BOLTS				TIE BAR BOLTS		
Reagent Head#	# Bolts and Thread Size	Torque <sup>(2)</sup>		# Bolts and Thread Size	Torque <sup>(2)</sup>	
		FT-LBS	N-M		IN-LBS	N-M
W094147	8. 5/16-18	1.5	2.0	2 * 5/16-18	3.8	0.4
W094544	4 * 3/8-16	5.9	8.0	2 • 3/8-16	9.3	1.1
W094689	4 * 1/2-13	15.2	20.6	2*1/2-13	47.5	5.4
W094689	4*1/2-13	15.2	20.6	4 * 3/8-16	17.8	2.0
W096319	4 • 3/4-10	44.9	60.9	2 * 1/2-13	4.8	6.2

1. Reagent heads in these categories can be referenced by the #of bolts and thread size.
2. Torque values are for Grade 8, Carbon Steel Socket Head Cap screws only, with lubricated threads.

## 15. APPENDIX V - ACCESSORIES

### 15.1 PULSAtrol Pulsation Dampener

#### Installation, Operation, and Removal Instructions

The PULSAtrol is a pneumatically charged diaphragm-type chamber that intermittently stores energy. Used on the inlet, it will improve NPIPA (Net Positive Inlet Pressure available) characteristics of the suction piping system. On the discharge line it will reduce peak pressures and pulsating flow variations.

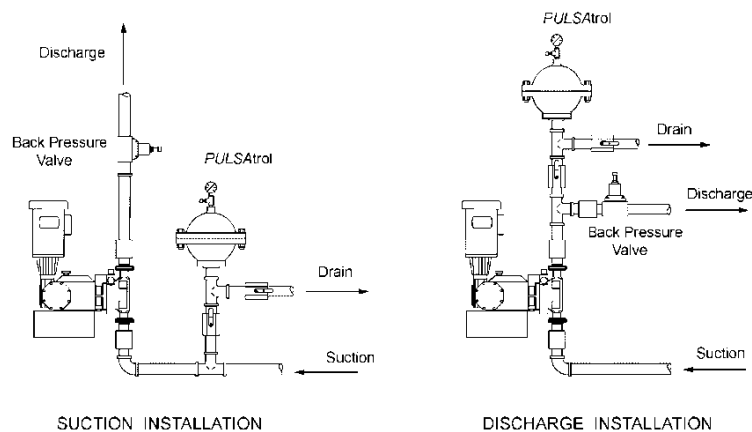

Figure 38

#### Installation

On both discharge and suction lines, it is desirable to mount the PULSAtrol as close to the pump connection as possible. It can be mounted in any position: horizontally, vertically, or at any angle. A shutoff valve should always be used between the piping system and PULSAtrol. If the discharge line is open to atmospheric pressure, a backpressure valve should also be incorporated in the system near the PULSAtrol to assure proper operation. Pulsation dampeners do require regular maintenance and inspection. Charge pressure should be checked every 2-4 months and renewed as needed. Temperature, pressure, and other variables will affect charge life and diaphragm/bladder life.

#### Discharge Setup

The PULSAtrol may be pre-charged with air or nitrogen. When properly pre-charged the diaphragm is positioned against the bottom liquid chamber. It is therefore necessary to drain all liquid below the diaphragm and vent to atmospheric pressure when pre-charging.

Use the pre-charge pressure as determined from the PULSAtrol selection and sizing procedure (Catalog No. 211). This can vary from 50 to 80% of mean line pressure in accordance with fluctuation level selected. The PULSAtrol is now ready for service and the diaphragm will move to a neutral position as liquid enters the chamber.

#### Use the following to complete a Pre Charge Procedure for Discharge Installation

1. Calculate the pre-charge pressure
  - a. Mean Line Pressure (psig) + Atmospheric Pressure = Absolute Pressure (psia)
  - b. Absolute Pressure (psia) x Pre-charge Percentage (80% max) = Pressure Absolute
  - c. Pressure Absolute – Atmospheric Pressure = Pre-charge Pressure (psig)

2. Isolate PULSAtrol from line.
3. Carefully drain off process fluid by opening a drain valve (see recommended piping arrangement).
4. Apply pre-charge pressure (additional liquid may drain as diaphragm moves).
5. Close drain valve.
6. Place PULSAtrol in stream.

### Suction Setup (Flooded Suction)

Charge the PULSAtrol with adequate pressure to overcome the static suction head. Start up the pump. Depress the stem on the charge valve, but only during discharge strokes of the pump, until the gauge indicates pressure pulses. The diaphragm has now centered allowing the PULSAtrol to accumulate liquid while the pump is discharging. If too much air becomes released and the gauge will not indicate pressure pulses, recharge the PULSAtrol and repeat the procedure.

### Use the following to complete a Pre Charge Procedure for Suction Installation

1. Isolate accumulator from line.
2. Carefully drain off process fluid by opening a drain valve (refer to Figure 24).
3. Apply 5-10 psi pre-charge pressure (additional liquid may drain as diaphragm moves).
4. Close drain valve.
5. Bleed off all pressure on the PULSAtrol.
6. Open the valve to put PULSAtrol in stream.
7. Push in on the stem of the charging valve during the discharge stroke of the pump and release during the suction stroke.
8. Continue this for about 10 times and observe the compound gauge. As accumulator functions, the needle will go from pressure to vacuum.

### PULSAtrol Removal

When removing or disassembling a PULSAtrol, drain all piping and remove all air and process pressure. Assume that the diaphragm is broken and the chamber is flooded under pressure since the pressure gauge could be damaged. Separate chambers with caution in a direction away from the body.

## 15.2 Back Pressure Valve

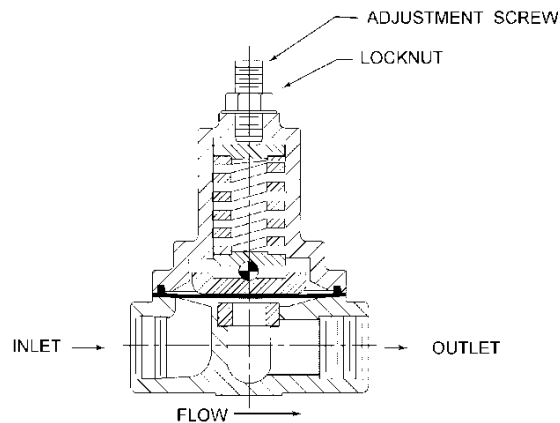

Figure 39

The Pulsafeeder diaphragm backpressure valve creates constant backpressure. A PTFE diaphragm, offering maximum chemical protection and service life, seals the spring and bonnet from process fluid. This diaphragm seals directly on a replaceable seat.

Be sure to install with fluid flow in direction of arrow on valve body. If arrow is missing from plastic valve body, install with flow exiting out center hole of valve body.

### **15.3 Pressure Relief Valve**

Pressure relief valves should be utilized in any system to protect the pump and other process equipment and piping from potentially damaging or unsafe pressures. It is critical that the pressure relief valve be mounted in the discharge piping system before any other devices that can potentially block or impede flow, or it cannot perform its intended function (refer to Figure 8). The pressure relief valve must be set to a pressure high enough to prevent unwanted fluid relief during normal process conditions. A setting that is approximately 10-20% above normal operating pressures is generally sufficient. The valve must also be set below the maximum pressure capability of the lowest rated device in the system. For example, if a Pulsapro pump is rated with a maximum pressure capability of 150 psi (approx. 10 bar) but the piping within the system is rated only to a maximum of 100 psi (approx. 7 bar) then the pressure relief valve must be set to a value lower than 100 psi.



**Pulsafeeder, Inc.**  
2883 Brighton Henrietta Town Line Road  
Rochester NY 14623  
+1 (585) 292-8000  
[www.pulsa.com](http://www.pulsa.com)