

PRODUCT INFORMATION

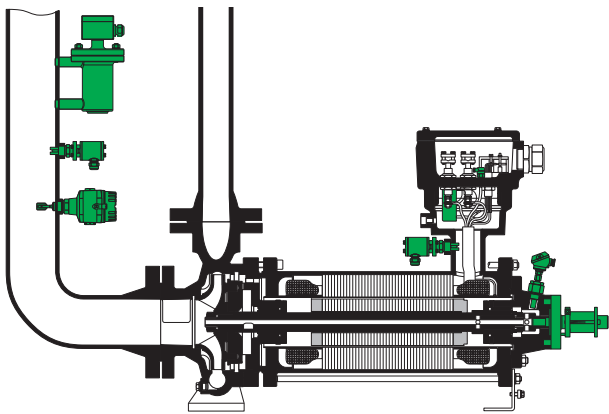

Monitoring equipment  
for hermetically sealed  
centrifugal pumps  
with canned motor

## General

---

When used as intended, hermetically sealed centrifugal pumps with canned motor are hydrodynamically (radially) and hydraulically (axially) balanced and absolutely free from wear (HERMETIC technology: „ZART®“, Zero Axial and Radial Thrust). However, the proper function can be disturbed by an inadmissible operating method or an unpredictable or unconsidered incidence.

Efficient monitoring equipment should play an important role in ensuring that failures are detected at an early stage, before they become a safety risk for persons and the environment. A reliable monitoring system prevents costly damage to the pump and a possibly long shutdown of the production plant. In case of safety-related failures, the monitoring equipment has to ensure the shutdown of the pump.

## Contents

---

<b>Complete overview of the safety- and function-related monitoring equipment .....</b>	<b>4</b>
<b>Monitoring equipment for the safe operation of hermetically sealed centrifugal pumps with canned motor in potentially explosive atmospheres.....</b>	<b>6</b>
Requirements to ensure the explosion protection of hermetically sealed centrifugal pumps with canned motor of type of protection flameproof enclosure .....	6
Additional requirements to ensure the explosion protection of hermetically sealed centrifugal pumps with canned motor of type of protection oil immersion .....	8
<b>Detailed description of the monitoring equipment</b>	
<b>Level monitoring .....</b>	<b>10</b>
Magnetic float switch .....	10
Optoelectronic liquid level limit transducer .....	13
Vibration limit switch.....	17
<b>Temperature monitoring .....</b>	<b>23</b>
Liquid temperature.....	23
Thermal motor protection .....	28
<b>Rotor position monitoring .....</b>	<b>32</b>
<b>Rotation monitoring .....</b>	<b>37</b>
<b>Pressure monitoring.....</b>	<b>41</b>
Diaphragm pressure switch .....	41
Pressure transmitter.....	42

## Complete overview of the safety- and function-related monitoring equipment

---

In order to ensure the proper function of a hermetically sealed centrifugal pump with canned motor, HERMETIC provides the following monitoring equipment:



### **Level monitoring of the pumped liquid for detecting and avoiding dry run**

The pump's interior and rotor chamber must be always filled with the pumped liquid for reasons of safety.

HERMETIC provides suitable level monitoring equipment for each pump complying with the explosion protection requirements according to directive 94/9/EC. Level monitoring can be recommended principally for application cases which do not mandatory comply with explosion protection requirements. Level monitoring prevents the pump from running dry and to be affected by major damages such as by destruction of the slide bearings or by exceeding inadmissible high temperatures caused by missing cooling and lubricating flow. In addition the pump can be prevented from cavitation damages by means of level monitoring equipment which are caused by evaporation of boiling liquids in the suction pipe.



### **Temperature monitoring for detecting and avoiding inadmissible high temperatures in the pump and the motor**

Temperature monitoring ensures that the pump is switched off when achieving inadmissible high temperatures.

HERMETIC provides suitable temperature monitoring equipment for each pump complying with explosion protection requirements according to directive 94/9/EC. Monitoring of the liquid temperature allows a reliable control to ensure the operation of the pump within the admissible range and to ensure the internal motor cooling of a canned motor pump. For liquids with a pour point that is higher than the ambient temperature, the liquid temperature monitoring can also be used to prevent the start-up of the pump as long as the maximum admissible viscosity of the liquid is reached.

In order to protect canned motors against inadmissible high temperatures, the winding is equipped either with PTC thermistors or PT100 resistance thermometers.



### **Rotor position monitoring for detecting and avoiding axial wear**

Axial thrust balancing is mainly influenced by the operating method of the pump, plant conditions and various physical properties of the pumped liquid. For an early detection of an imminent malfunction it is recommended to install a rotor position monitoring device. This electronic protection equipment monitors the axial shaft position of the rotor during operation in a hermetically sealed and contact-free way. Combined with the level and temperature monitoring an efficient detection of imminent failures is possible.



### **Rotation monitoring for detecting and avoiding incorrect phase sequence**

The correct rotating direction of hermetically sealed centrifugal pumps with canned motor cannot be checked visually from the outside. Due to a wrong phase sequence in the power line the pump is operated with an incorrect rotating direction without being noticed what might result in considerable damages to the pump. By default, hermetically sealed centrifugal pumps with canned motor are equipped with an electronic rotation monitor in the form of a phase sequence relay.



### Pressure monitoring for detecting a damaged and leaking stator liner

During normal operation, the hermetically sealed stator liner prevents the intrusion of the pumped liquid out of the pressurised rotor chamber into the stator chamber. If, in case of a failure, the stator liner gets damaged, then any leakage that may subsequently occur can be detected due to the pressure increase in the stator chamber by means of an appropriate monitoring equipment. For canned motors of type of protection oil immersion, the pressure monitoring of the stator chamber is mandatory.



### Level monitoring of the motor protective liquid used in hermetically sealed centrifugal pumps with canned motor of type of protection oil immersion

For canned motors of type of protection oil immersion, the motor winding is completely surrounded by a protective liquid to eliminate the possibility of an ignition source. In order to ensure that the winding is sufficiently immersed, level monitoring of the motor protection liquid is required. HERMETIC provides suitable level monitoring equipment of the motor protective liquid for each pump with canned motor of type of protection oil immersion complying with the explosion protection requirements according to directive 94/9/EC.

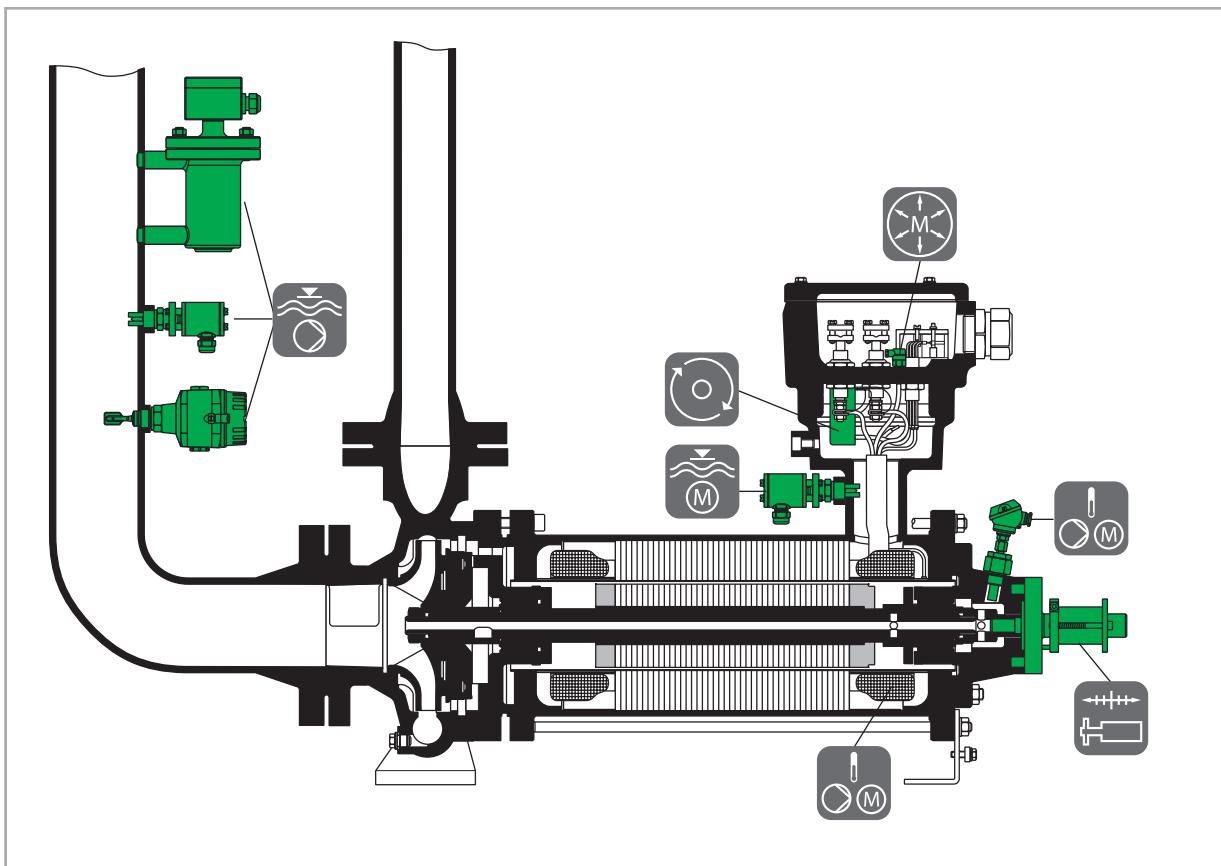

# Monitoring equipment for the safe operation of hermetically sealed centrifugal pumps with canned motor in potentially explosive atmospheres

---

## Requirements to ensure the explosion protection of hermetically sealed centrifugal pumps with canned motor of type of protection flameproof enclosure

Hermetically sealed centrifugal pumps are principally manufactured for use in potentially explosive atmospheres. For this reason the pumps comply with electrical as well as non-electrical explosion protection requirements.

### Electrical explosion protection

Both the canned motor and the terminal box as electrical equipment comply with the electrical explosion protection requirements according to EN 60079.

The canned motor is designed in type of protection flameproof enclosure "d" according to EN 60079-1. For this type of protection, all parts which are capable of igniting an explosive atmosphere due to sparks and electric arcs are placed inside an enclosure that is capable of withstanding the pressure of an internal explosion and also preventing the explosion from being transmitted to the atmosphere surrounding the enclosure.

The terminal box of the canned motor is designed in type of protection increased safety "e" according to EN 60079-7. Larger clearances and creepage distances, along with the implementation of additional measures, ensures the prevention of sparks and electric arcs inside the terminal box, as well as excessive temperatures during normal operation.

### Non-electrical explosion protection

The hydraulic part of the pump and the rotor chamber as non-electrical equipment are designed in type of protection constructional safety "c" according to EN 13463-5. Provided that the pump as part of the process system is permanently filled with liquid, the formation of an explosive atmosphere in the wetted inner chamber of the pump is impossible. A risk of ignition inside the pump can be ruled out in this case. If the permanent filling with liquid cannot be guaranteed during operation, then appropriate monitoring equipment with an ignition protection level IPL 1 according to EN 13463-6 is required. Since, as a result of its design, all rotating parts are located inside the pump, the risk of igniting the atmosphere outside can only be caused by hot surfaces.

### Hot surfaces

As well as the mechanical and electrical ignition sources inside the pump, there is also a risk of ignition from hot surfaces. The surface temperature of the pump to the surrounding atmosphere is dependent on the temperature of the liquid to be pumped as well as the self-heating of the pump, e.g. due to friction, eddy currents or motor losses.

In order to ensure the explosion protection, the maximum surface temperature needs to be below the ignition temperature of the gas/air mixture, in which the pump is applied, at all times.

In order to prevent the maximum permissible surface temperature from being exceeded, and thereby to continue to meet the conditions of the required temperature class, the temperature has to be monitored at the pump.

For hermetically sealed centrifugal pumps with canned motor, two temperature monitoring methods are possible:

1. Monitoring of the pumped liquid temperature: In this case, monitoring equipment with an ignition protection level IPL 1 according to EN 13463-6 is required.

This type of monitoring enables a more precise control of the proper function of the pump, due to the temperature of the heated motor cooling flow being measured.

2. Monitoring of the motor winding temperature: In this case, monitoring equipment with a safety integrity level SIL 1 according to EN 50495 is required. Alternatively, thermal monitoring equipment can be used, that has been approved according to directive 94/9/EC by a notified body for use as monitoring equipment and that has been marked accordingly. For this type of monitoring, the pump may also be operated in combination with a frequency converter.

For canned motors of type of protection flameproof enclosure, either one of the monitoring methods, or a combination of both, can be used. When selecting the temperature monitoring equipment, attention needs to be paid to the application and pump specific requirements concerning the explosion protection.

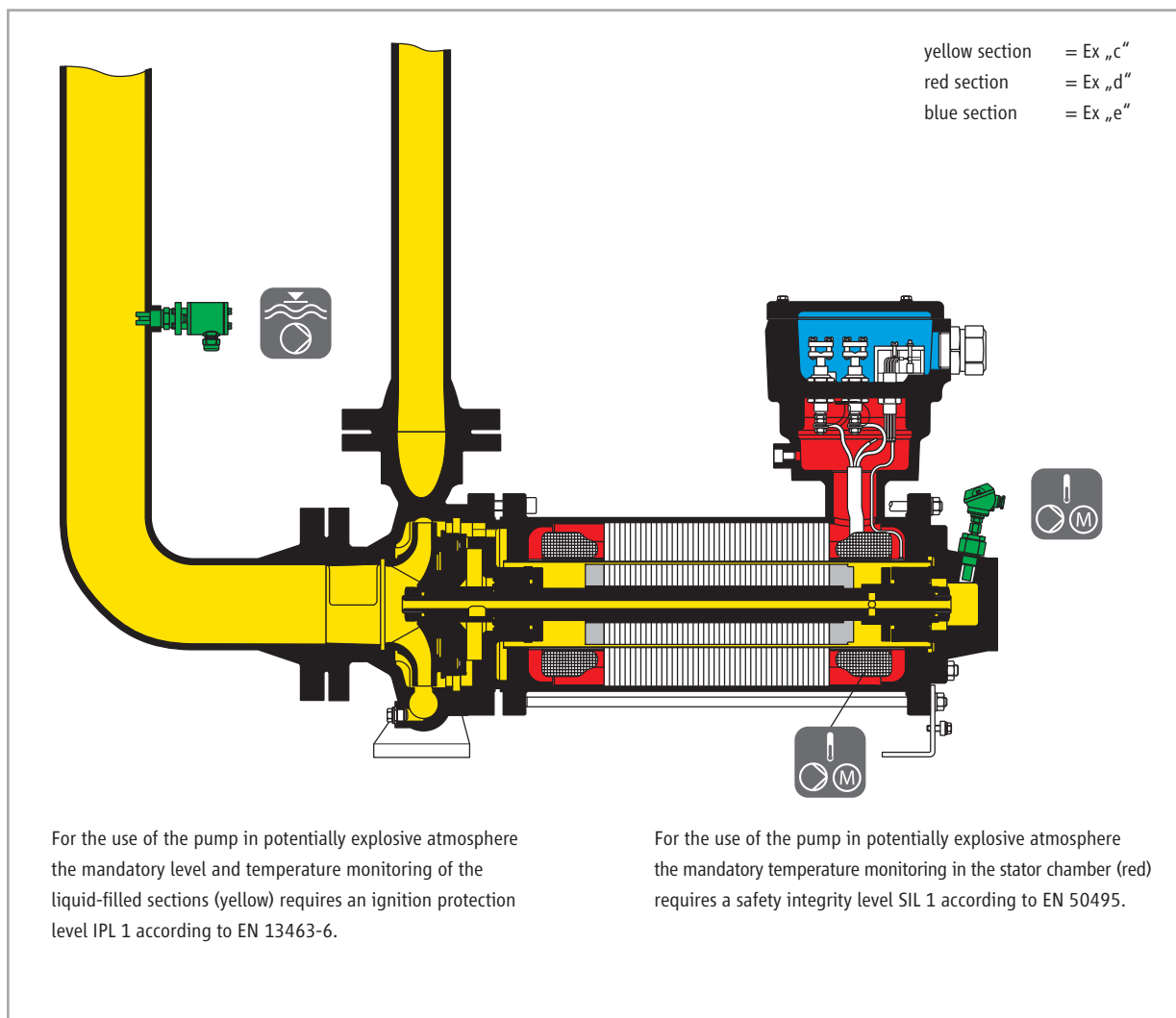

---

## **Additional requirements to ensure the explosion protection of hermetically sealed centrifugal pumps with canned motor of type of protection oil immersion**

For hermetically sealed centrifugal pumps with canned motor of type of protection oil immersion, the same requirements as described on page 6–7 apply, apart from a few exceptions:

### **Electrical explosion protection**

The canned motor is designed in type of protection oil immersion “o” according to EN 60079-6. For this type of protection, all parts which are capable of igniting an explosive atmosphere due to sparks and electric arcs are immersed in a protective liquid, so that the formation of an explosive atmosphere is impossible. Therefore it has to be ensured that the winding is sufficiently immersed. For the purpose of level monitoring, only a screw-mounted, pressure- and temperature-resistant sight glass is provided by default. Alternatively, an electronic level monitoring equipment, that is suitable for the application conditions, can be used. The level monitoring also requires a safety integrity level SIL 1 according to EN 50495.

An additional pressure monitoring equipment is required for the following reasons:

- Detection and avoidance of excessive pressures in the stator chamber due to the thermal expansion of the motor protection liquid.
- Detection of pumped liquid entering the stator chamber as a consequence of a damaged stator liner.

By default, a pressure switch is installed in the motor terminal box for this purpose, and has to be connected to an intrinsically safe circuit. The pressure switch also acts as a pressure relief device according to EN 60079-6, clause 4.4.

### **Hot surfaces**

For hermetically sealed centrifugal pumps with canned motor of type of protection oil immersion, both of the temperature monitoring methods described on page 6–7 are mandatory, i.e. the temperature monitoring of the pumped liquid as well as the temperature monitoring of the motor winding.



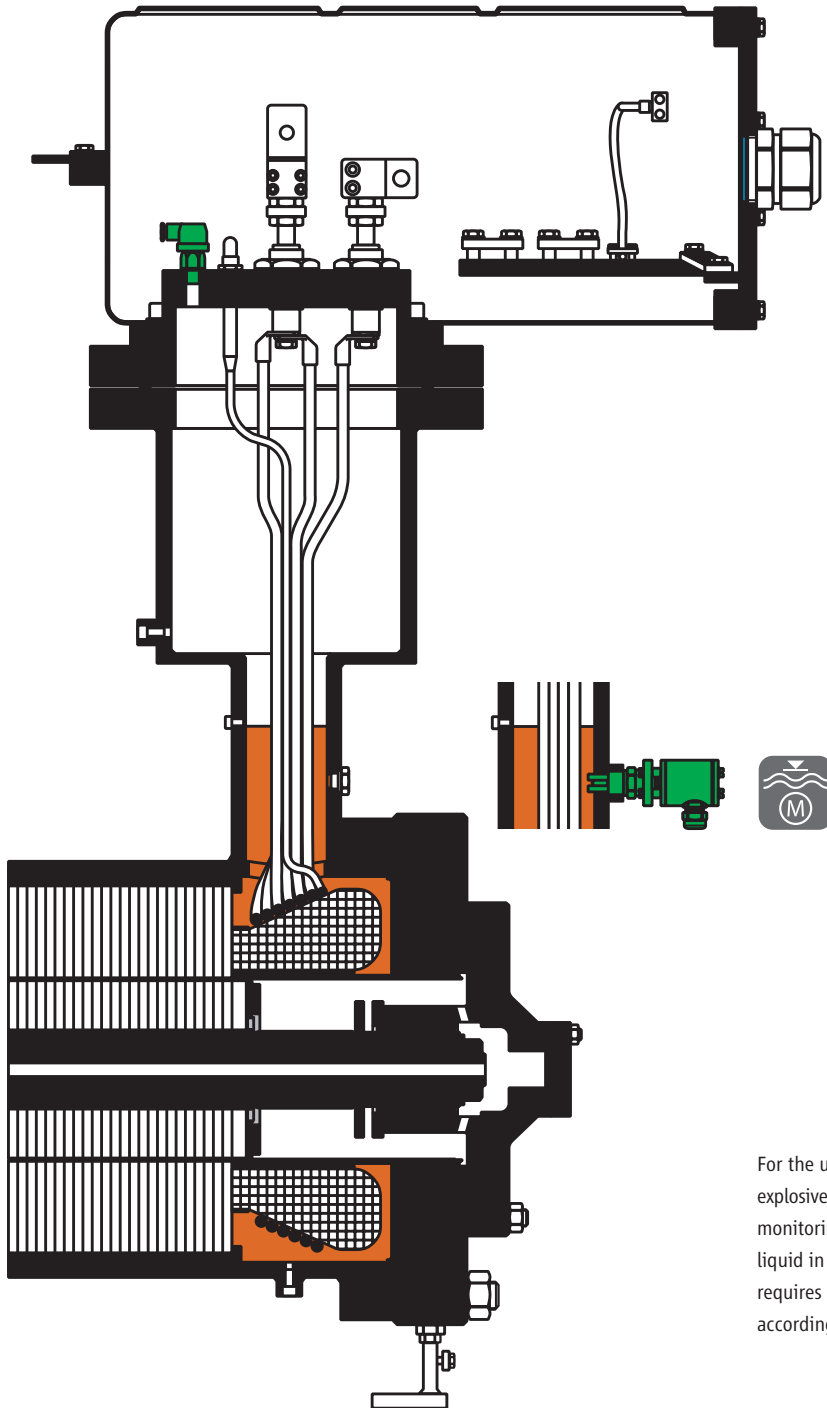

For the use of the pump in potentially explosive atmosphere the optional level monitoring for the motor protection liquid in the stator chamber (brown) requires a safety integrity level SIL 1 according to EN 50495.

# KSR magnetic float switch (level monitor)

## Function

Within the KSR magnetic float switch, a float equipped with a magnet moves on a guide tube which has an inert gas contact (reed contact) inside. If the liquid level rises or falls, the installed reed contact is activated via the magnet.

The correct functioning of the installed contact circuit may be checked by means of a movable contact insert.

## Model / Type

Manufacturer: KSR KUEBLER Niveau-Messtechnik AG

- KSR magnetic float switch  
(standard design, PN25)  
type 60-AFV HP-VS/CF-L110-V62A-AS-EX,  
Mat. no. 266211008  
Operating temperature range:  $-70^{\circ}\text{C}$  to  $+100^{\circ}\text{C}$

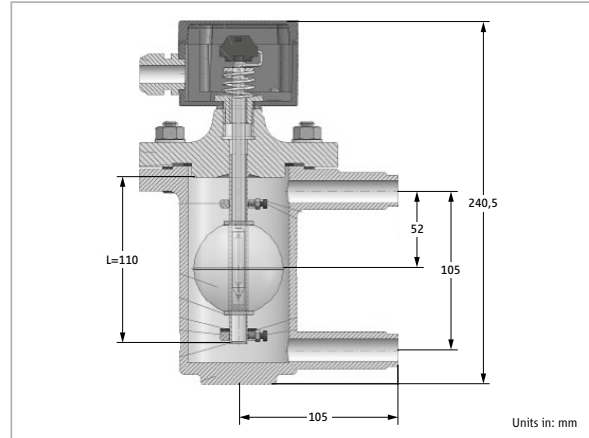

- KSR magnetic float switch  
(for hot pumped liquids, PN25)  
type AFV HP-VS/HHT-CF-L110-V62A-AS-EX,  
Mat. no. 266211010  
Operating temperature range:  $-10^{\circ}\text{C}$  to  $+350^{\circ}\text{C}$

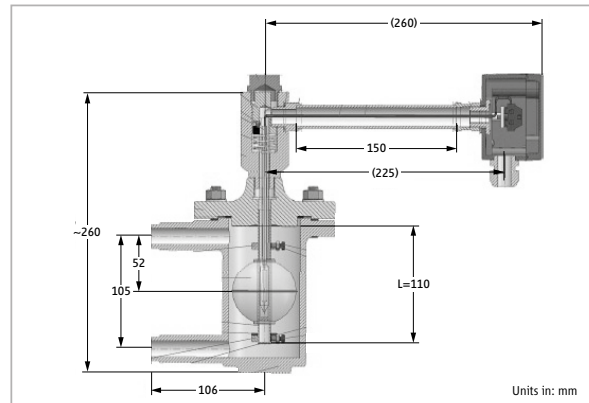

- KSR magnetic float switch  
(cooler variant, PN25)  
type 60-AFV HP-VS/CF-L110-V62A-AS-EX  
with air vent valve and DN15, PN40 flange, grade C  
(float switch side) and grade B1 (customer's connection  
point side); "cooler" float switch, DN15, PN40 flange,  
grade D.  
Operating temperature range:  $-70^{\circ}\text{C}$  to  $+100^{\circ}\text{C}$   
Mat. no. 25620042 (with valve),  
Mat. no. 266211009 (without valve)

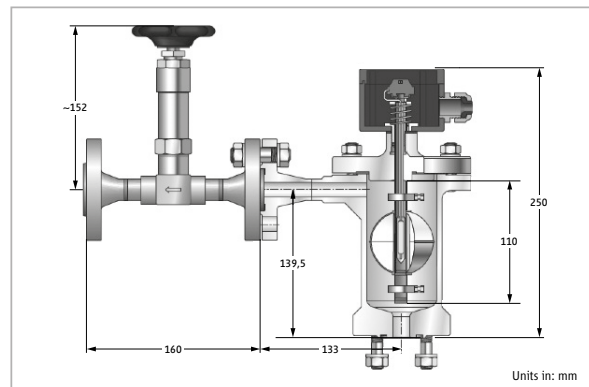

**Explosion protection according to Directive 94/9/EC**

EC-type examination certificate KEMA 01 ATEX 1053 X

EN 60079-0: 2006, EN 60079-11: 2007, EN 60079-26: 2007, EN 61241-0: 2006, EN 61241-11: 2006

**Design**

Stainless steel (1.4581) casing; stainless steel (1.4571) float; stainless steel (1.4571) guide tube; aluminium connection head; protection rating: IP 65

**Normal design**

For densities  $\geq 625$  kg/m<sup>3</sup>

Pressure rating: PN 25 (EN 764-1), stainless steel (1.4571) float

Hydrostatic test pressure: 37.5 bar

**Special design**

For densities  $\geq 480$  kg/m<sup>3</sup> pressure rating PN 25, titanium float (on request)

**Electrical data**

Power supply circuit of the reed contacts: "Intrinsically safe" protection ([Ex ia] IIC), only to be connected to a certified intrinsically safe circuit with the following associated maximum values:  $U_i = 36$  V;  $I_i = 100$  mA;  $C_i = 0$  nF;  $L_i = 0$   $\mu$ H

**Installation in pipework**

The KSR magnetic float switch can be directly welded onto the pipe using 2 welding studs. It is beneficial to install the KSR magnetic float switch within a vertical section of the pipe on the suction side. The monitoring device should be installed at least at the level of the discharge flange of the pump. For boiling liquids (liquefied gases) and when used as sole protection against dry running, the device must be fitted at level of NPSHp + 0.5m. No shut-off device are allowed between the float and the suction nozzle. If such an installation is not possible, the KSR magnetic float switch can alternatively be installed on the discharge side of the pipe.

Circuit diagram

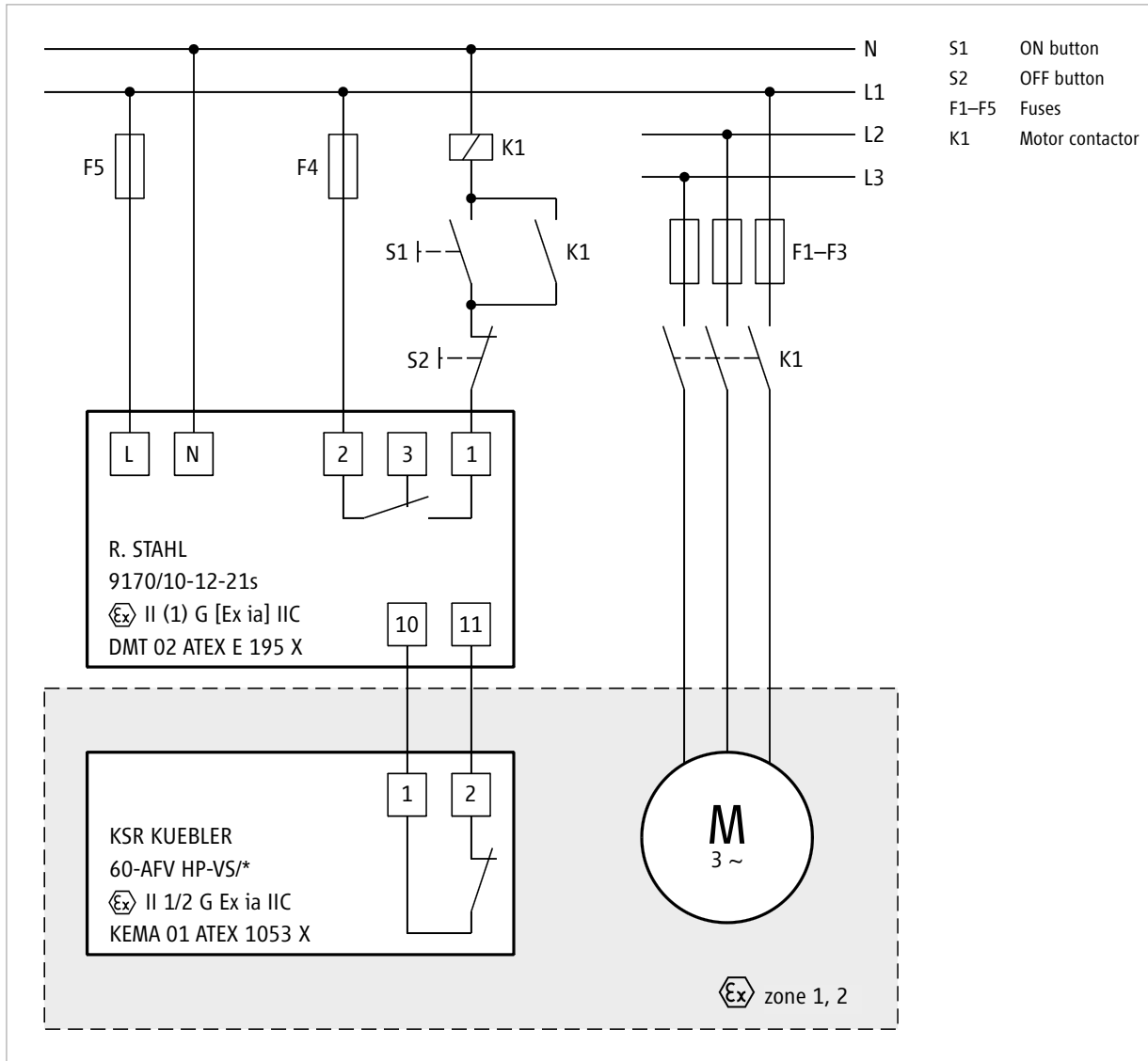

Example of a connection involving the KSR magnetic float switch

Exemplary drawing. Contains components that can be quoted on request but are not necessarily included in your individual quotation.

HDE-DB-7.2.3-KSR-EN-00/2016

All details as stated in this document comply with the technical standard that is applicable at the date of printing. These details are subject to technical innovations and modifications at any time.



HERMETIC-Pumpen GmbH  
Gewerbestrasse 51 · D-79194 Gundelfingen  
phone +49 761 5830-0 · fax +49 761 5830-280  
hermetic@hermetic-pumpen.com  
www.hermetic-pumpen.com

# Optoelectronic liquid level limit transducer

## Function

The optoelectronic liquid level limit transducer uses the different refractive properties of gases and liquids to optically determine the fill level. Light from an infrared LED is directed through a glass rod with a tapered end. For the medium gas, the light is almost totally reflected and directed back to a phototransistor. If liquid surrounds the sensor surface, then the light is fully redirected into the liquid. The phototransistor consequently receives no more light. The different signals thus generated are simply evaluated as "WET" and "DRY" signals and the resulting voltage is transferred to the controller.

## Model / Type

Manufacturer: KSR KUEBLER Niveau-Messtechnik AG

- Optoelectronic liquid level limit transducer of type KSR-OPTO.211 300 000.0660 with screw thread, mat. no. 266290010
- Optoelectronic liquid level limit transducer of type KSR-OPTO.211 300 000.0660 with DN 25, PN 40 flange, mat. no. 266290011
- Optoelectronic liquid level limit transducer of type KSR-OPTO.211 300 000.0660 with 1", 150 lbs flange, mat. no. 266290041
- Optoelectronic liquid level limit transducer of type KSR-OPTO.211 300 000.0660 with 1", 300 lbs flange, mat. no. 266290042

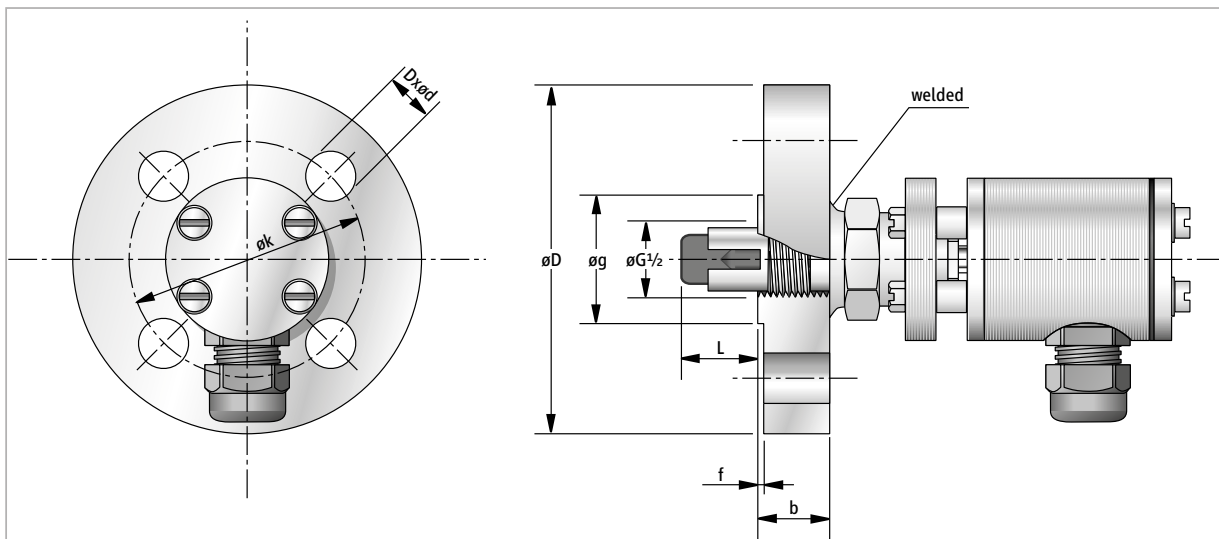
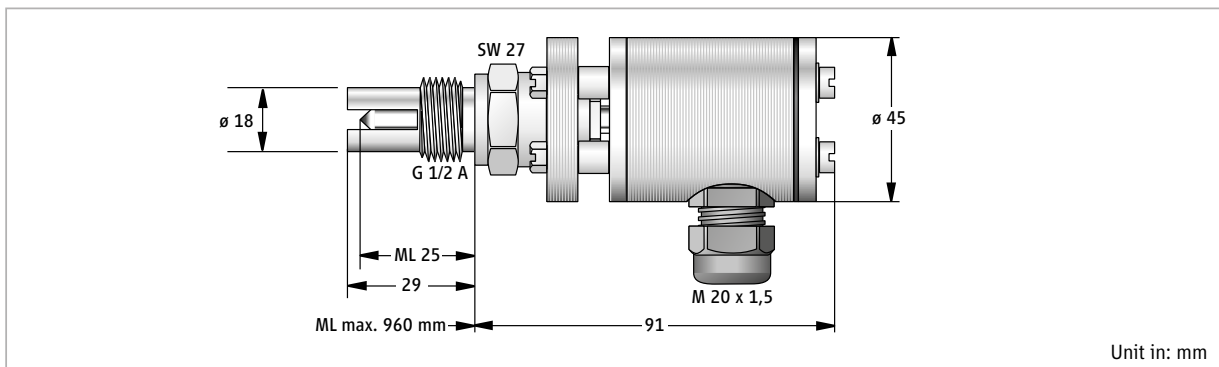

Blind flange	D	k	b	d	n	g	f	L
DN25 / PN40-DIN 252	115	85	18	14	4	–	–	25
DN1" / 150lb-ANSI B16.5	108	79.2	14.2	15.7	4	50.8	1.6	25
DN1" / 300lb-ANSI B16.5	123.9	88.9	17.5	19.0	4	50.8	1.6	25

**Explosion protection according to Directive 94/9/EC**

EC-type-examination certificate ZELM 06 ATEX 0299

EN 60079-0: 2009, EN 60079-11: 2007, EN 60079-26: 2007, EN 60079-28: 2007

SIL 1

**Design**

Sensor with stainless steel (1.4571) connecting thread / flange; glass sensor with stainless steel connection head; special Protection type: Ex ib op is IIC T6 (sensor: zone 0); protection rating: IP 65; design characteristic: NO contact for rising level

**Application conditions**

Optoelectronic liquid level limit transducer of type KSR-OPTO.211 300 000.0660: –65 °C to +250 °C

Ambient temperature range: –40 °C to +75 °C

**Normal design**

No density restrictions

Pressure rating up to PN 250 (EN 764-1)

**Electrical data**

Signal circuit of type of protection intrinsic safety Ex ib IIC. Only to be connected to a certified intrinsically safe input circuit with the following associated maximum values:  $U_i = 9.7$  V DC,  $I_i = 149$  mA,  $P_i = 1$  W

**Installation**

The optoelectronic transducer can be installed directly in the piping. If the transducer is installed in a vertical leg of the suction-side piping, it must at least be as high as the pump's discharge nozzle, and there must be no shut-off device between the sensor and the suction nozzle. If it is not possible to install the optoelectronic transducer in this way, it may alternatively be installed on the discharge side. The sensor probe should extend at least 10 mm into the cross-section of the pipe, but must be more than 15 mm away from the pipe's far wall. In this case, the control device should be at least as high as the pump's discharge nozzle. With boiling liquids (liquefied gases) and when being used for dry-running protection, the device must be installed at NPSHp +0.5 m. There must be no shut-off device present between the float and the suction nozzle.

**Controller and power supply for Optoelectronic Transducers**

A controller of type KSR-OPTO.2502.XX, produced by KSR KUEBLER Niveau-Messtechnik AG, is a suitable trigger device for the optoelectronic liquid level limit transducer.

**Model / Type**

Manufacturer: KSR KUEBLER Niveau-Messtechnik AG

- Controller of type KSR-OPTO.2502.11, 230 VAC  $\pm$  10 %, 2.8 VA, mat. no. 265930840
- Controller of type KSR-OPTO.2502.41, 24 VDC  $\pm$  25 %, 3.0 W, 48 Hz to 68 Hz, mat. no. 265930850

**Explosion protection according to Directive 94/9/EC**

EC-type-examination certificate ZELM 06 ATEX 0300

EN 60079-0: 2009, EN 60079-11: 2007

**Intrinsic safety "i"**

The controllers have intrinsically-safe control inputs of type of protection [Ex ib] IIC.

**Installation**

The device must be installed outside the hazardous area, since only the control circuit is intrinsically safe. The only action required is to connect a two-wire signal line to the controller.

**Electrical data**

Control circuit (connections WS, BR, GN): type of protection intrinsic safety [Ex ib] IIC

maximum values:  $U_0 = 9.6 \text{ V}$ ,  $I_0 = 149 \text{ mA}$ ,  $P_0 = 1 \text{ W}$

1 changeover switch signal / 1 changeover switch failure

**Max. cable length**

600 m for cross-sectional area of 1.5 mm<sup>2</sup>

**Output circuit (connections 1, 2, 3) – signal relay**

Maximum DC load: 40 V / 2 A

Maximum AC load: 250 V / 3 A

Maximum switching capacity: 100 VA

**Output circuit (connections 4, 5, 6) – failure relay**

Maximum DC load: 40 V / 2 A

Maximum AC load: 250 V / 3 A

Maximum switching capacity: 100 VA

**Mechanical data**

Dimensions: 200 x 120 x 75 mm

Weight: approx. 730 g

Place of installation: outside the potentially explosive area

Ambient temperature range for Macrolon housing:  $-40^\circ\text{C}$  to  $+40^\circ\text{C}$

Macrolon housing protection rating: IP 65

Circuit diagram

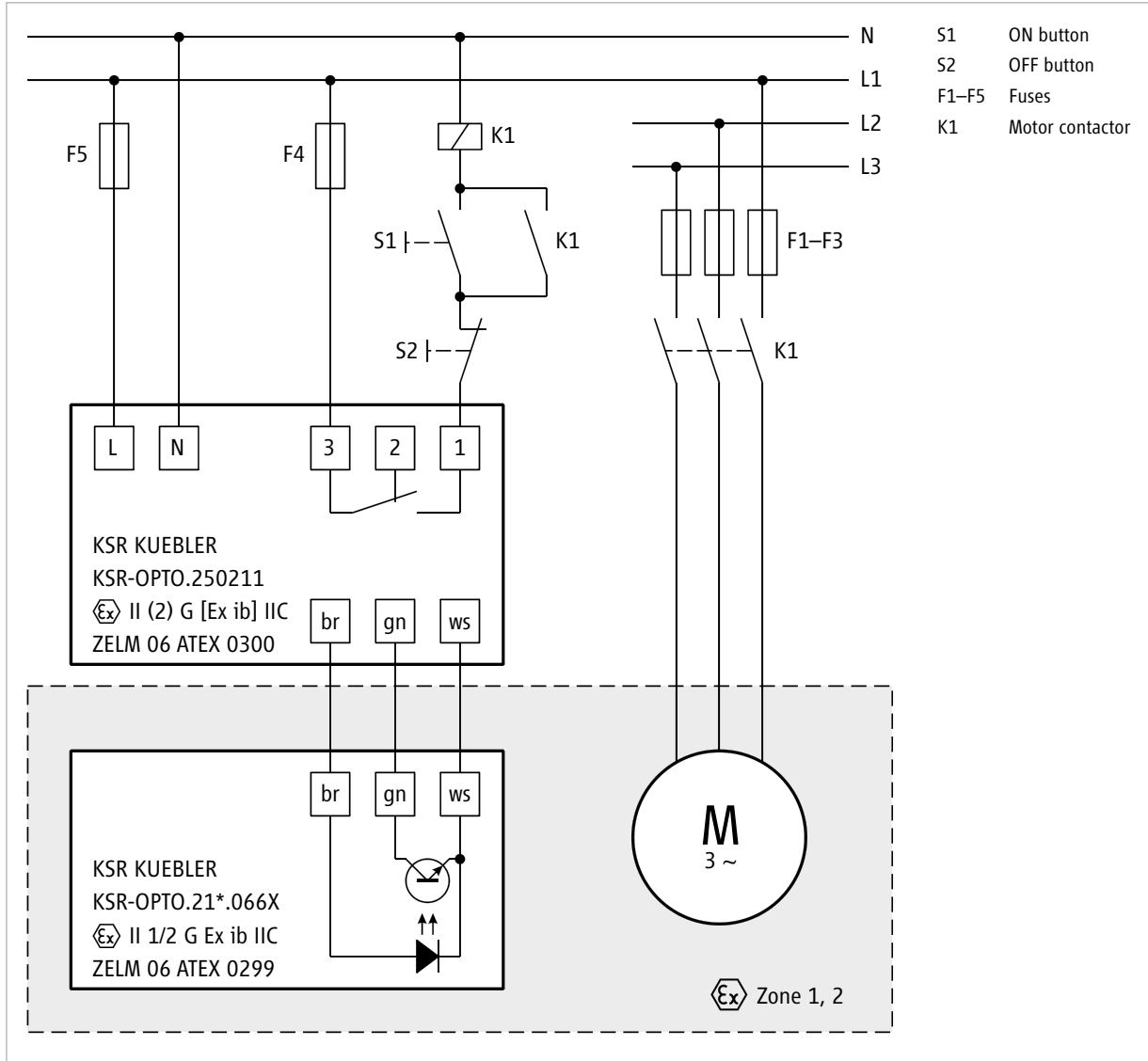

Example of connecting the optoelectronic liquid level limit transducer

Exemplary drawing. Contains components that can be quoted on request but are not necessarily included in your individual quotation.

HDE-DB-7.2.3-OPTO-EN-00/2016

All details as stated in this document comply with the technical standard that is applicable at the date of printing. These details are subject to technical innovations and modifications at any time.



HERMETIC-Pumpen GmbH  
 Gewerbestrasse 51 · D-79194 Gundelfingen  
 phone +49 761 5830-0 · fax +49 761 5830-280  
 hermetic@hermetic-pumpen.com  
 www.hermetic-pumpen.com



## Vibration limit switch

### Function

The tuning fork of the sensor oscillates at a natural frequency. If it is immersed in liquid, the oscillatory frequency is reduced. This change in frequency activates the limit switch. The functioning of the switch is not affected by flows, turbulence, gas bubbles, vibration, solid matter or deposit.

### Model / Type

Manufacturer: Endress+Hauser Messtechnik GmbH+Co. KG

Vibration limit switch of type FTL50 (Liquiphant) with electronic module of type FEL55; can be connected directly to a PLC (programmable logic controller).

Types of design:

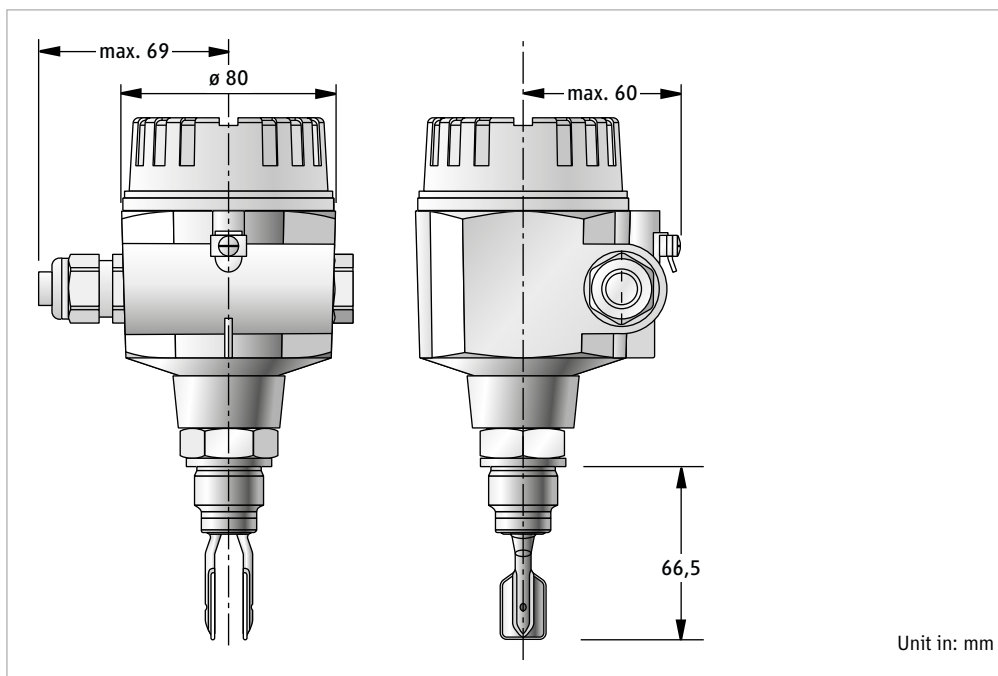

FTL50 model; aluminium housing (F13/F17); G 3/4 threaded connection

Vibration limit switch

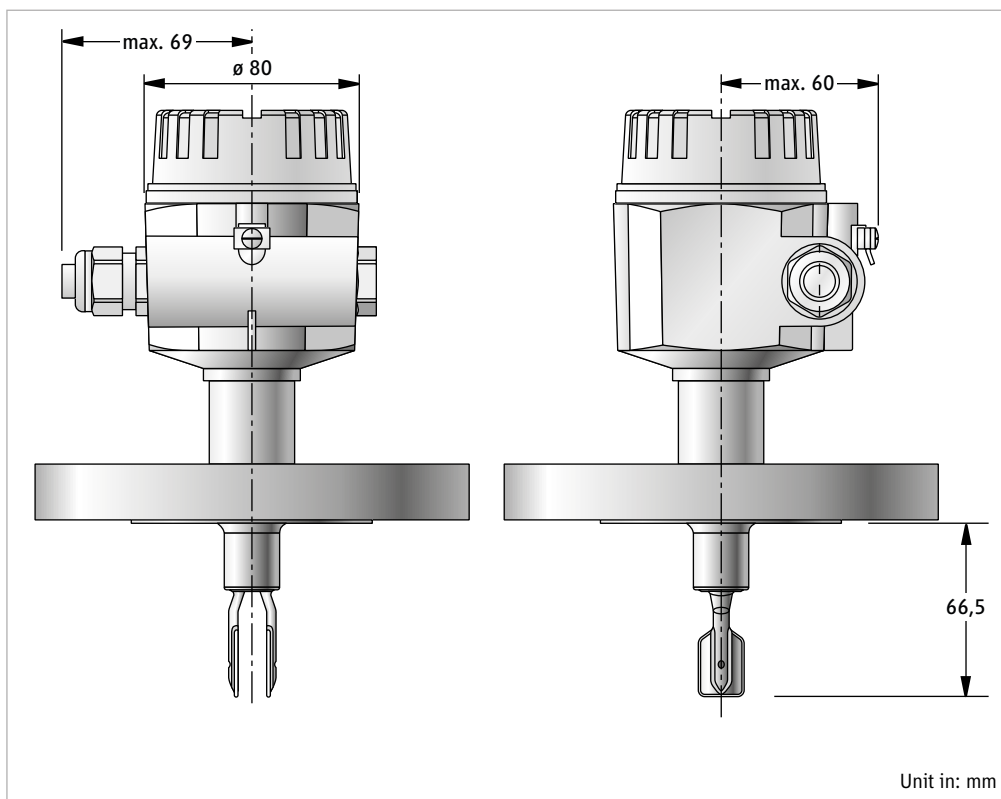

Unit in: mm

FTL50 model; aluminium housing (F13/F17); DN 50 flange connection

**Explosion protection according to Directive 94/9/EC**

EC-type examination certificate KEMA 99 ATEX 5172 X

EN 60079-0: 2009, EN 60079-11: 2007, EN 60079-26: 2007, EN 60079-27: 2008

SIL 2

**Design**

Liquiphant M FTL50	Mat no.	Certification, Ex i	Process connection, stainless steel	Probe length (type)	Electronic- system	Cable inlet
FTL50-GGQ2AA5G5C	266290230	ATEX II 1/2G Ex ia IIC T6	G3/4, ISO 228 thread, 316L	Compact	FEL 55	F13 aluminium, IP66/68, M20
FTL50-GDG2AA5G5C	266290231	ATEX II 1/2G Ex ia IIC T6	DN50, PN40 grade B1, flange EN 1092-1, 316L	Compact	FEL 55	F13 aluminium, IP66/68, M20
FTL50-GGM2AA5E5C	266290232	ATEX II 1/2G Ex ia IIC T6	NPT3/4", thread, 316L	Compact	FEL 55	F13 aluminium, NEMA4X/6P, NPT3/4
FTL50-GAE2AA5E5C	266290233	ATEX II 1/2G Ex ia IIC T6	2", 150 lbs, flange ANSI B16.5, 316L	Compact	FEL 55	F13 aluminium, NEMA4X/6P, NPT3/4
FTL50-GAF2AA5E5C	266290234	ATEX II 1/2G Ex ia IIC T6	2", 300 lbs, flange ANSI B16.5, 316L	Compact	FEL 55	F13 aluminium, NEMA4X/6P, NPT3/4

Liquiphant M FTL50	Mat no.	Certification, Ex d	Process connection, stainless steel	Probe length (type)	Electronic- system	Cable inlet
FTL50-KGQ2AA5G5C	266290235	ATEX II 1/2G Ex d IIC T6	G3/4, ISO 228 thread, 316L	Compact	FEL 55	F13 aluminium, IP66/68, M20
FTL50-KDG2AA5G5C	266290236	ATEX II 1/2G Ex d IIC T6	DN50, PN40 grade B1, flange EN 1092-1, 316L	Compact	FEL 55	F13 aluminium, IP66/68, M20
FTL50-KGM2AA5E5C	266290237	ATEX II 1/2G Ex d IIC T6	NPT3/4", thread, 316L	Compact	FEL 55	F13 aluminium, NEMA4X/6P, NPT3/4
FTL50-KAE2AA5E5C	266290238	ATEX II 1/2G Ex d IIC T6	2", 150 lbs, flange ANSI B16.5, 316L	Compact	FEL 55	F13 aluminium, NEMA4X/6P, NPT3/4
FTL50-KAF2AA5E5C	266290239	ATEX II 1/2G Ex d IIC T6	2", 300 lbs, flange ANSI B16.5, 316L	Compact	FEL 55	NEMA4X/6P, NPT3/4

### Application conditions

The Liquiphant FTL50 with electronic module FEL55 is a limit switch that can be used in all liquids

- for process temperatures ranging from  $-50^{\circ}\text{C}$  to  $+150^{\circ}\text{C}$
- for ambient temperatures at the electronics housing ranging from  $-50^{\circ}\text{C}$  to  $+50^{\circ}\text{C}$
- for viscosities of up to  $10000\text{ mm}^2/\text{s}$
- for densities  $\geq 0.5\text{ g/cm}^3$
- Operating pressure 64 bar

### Electrical data for the electronic module of type FEL55

Power supply and output circuits (terminals 1 and 2): "Intrinsic safety" protection([Ex ia] IIC), only to be connected to a certified intrinsically safe circuit with the following associated maximum values:  $U_i = 36\text{ V}$ ;  $I_i = 100\text{ mA}$ ;  $P_i = 1\text{ W}$ ;  $C_i = 0\text{ nF}$ ;  $L_i = 0\text{ mH}$

Output signal: 8...16 mA

### Installation

The vibration limit switch is directly flanged-mounted on, or screwed to, the pipe. It is beneficial to install the vibration limit switch within a vertical section of the pipe on the suction side. It must be at least as high as the discharge nozzle of the pump, and there must be no shut-off device between it and the suction nozzle. If such an installation is not possible, the vibration limit switch can alternatively be installed on the discharge side of the pipe.

*Standard - Heat exchanger design*

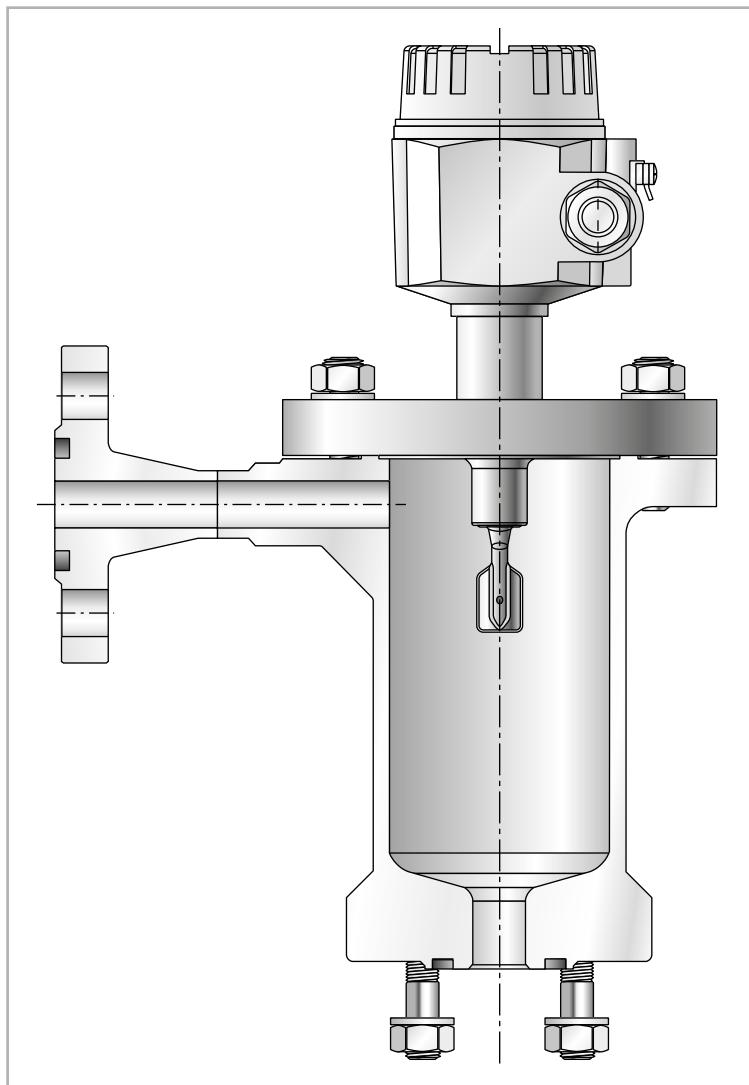

FTL50 model with vent flange

**Design**

Mat. no. Unit	Mat. no. Vibration limit switch	Connection for Vibration limit switch	Certification, Ex i	Vent flange	Connection for heat exchanger	Gasket
256213000	266290231	DN50, PN40 grade B1, flange EN 1092-1, 316L	ATEX II 1/2G Ex ia IIC T6	DN15, PN40 grade B1, Flansche EN 1092-1, 316L	DN15, PN40 grade D, Flansche EN 1092-1, 316L	Sigraflex HD
256213004	266290233	2", 150 lbs flange ANSI B16.5, 316L	ATEX II 1/2G Ex ia IIC T6	1/2", 150 lbs flange ANSI B16.5, 316L	1/2", 150 lbs flange ANSI B16.5, 316L	grooved gasket
256213001	266290234	2", 300 lbs flange ANSI B16.5, 316L	ATEX II 1/2G Ex ia IIC T6	1/2", 300 lbs flange ANSI B16.5, 316L	1/2", 300 lbs flange ANSI B16.5, 316L	grooved gasket
256213005	266290236	DN50, PN40 Form B1, Flansche EN 1092-1, 316L	ATEX II 1/2G Ex d IIC T6	DN15, PN40 grade B1, Flansche EN 1092-1, 316L	DN15, PN40 grade D, Flansche EN 1092-1, 316L	Sigraflex HD
256213006	266290238	2", 150 lbs flange ANSI B16.5, 316L	ATEX II 1/2G Ex d IIC T6	1/2", 150 lbs flange ANSI B16.5, 316L	1/2", 150 lbs flange ANSI B16.5, 316L	grooved gasket
256213007	266290239	2", 300 lbs flange ANSI B16.5, 316L	ATEX II 1/2G Ex d IIC T6	1/2", 300 lbs flange ANSI B16.5, 316L	1/2", 300 lbs flange ANSI B16.5, 316L	grooved gasket

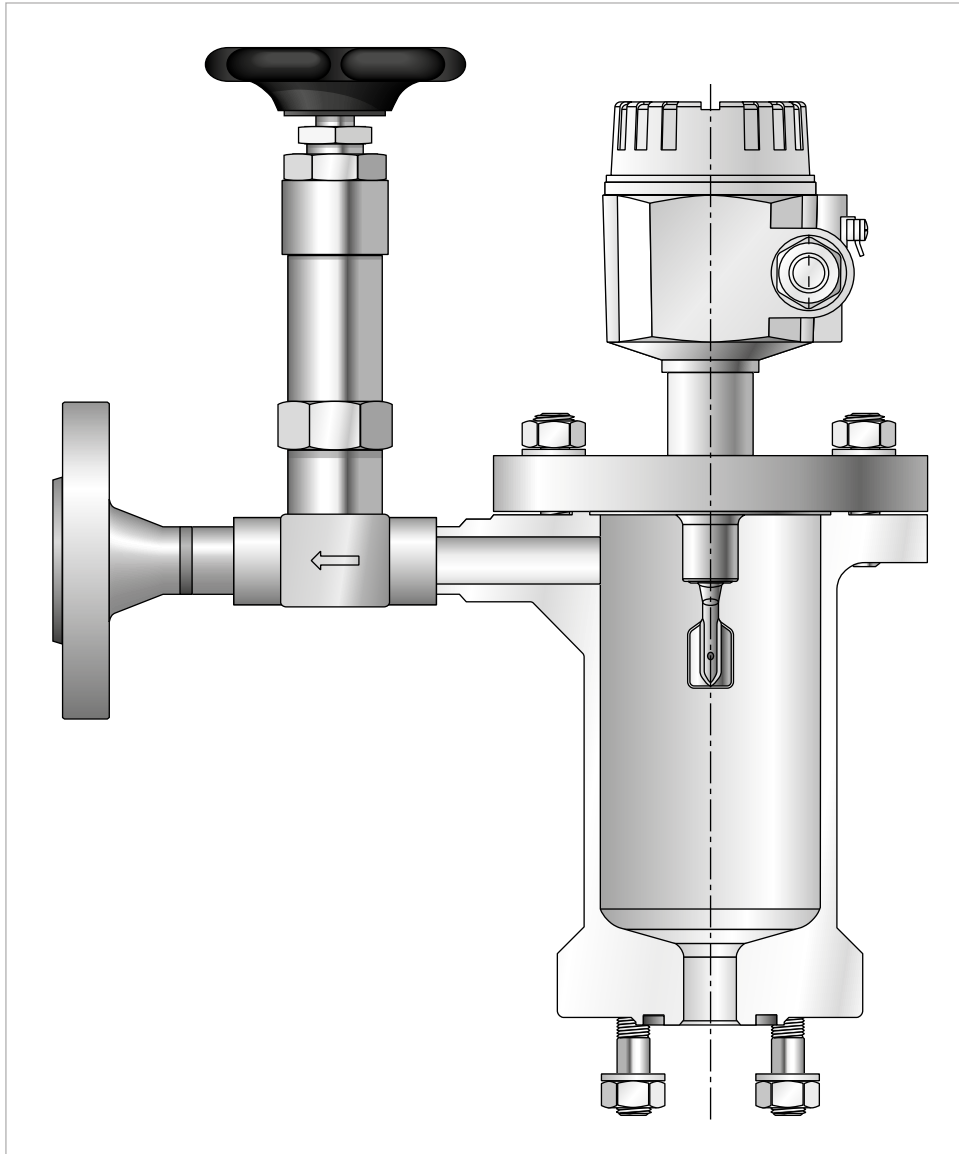
*Special - Heat exchanger design*

FTL model with valve and vent flange

On demand a valve can be welded and adapted to the vent flange.  
Available sizes from DN15-DN25, or DN1/2"-DN1".

The form of the sealing surface is selectable. Depending on the model, a reducer is needed.

In case of special media, an enlarged space for gases are necessary, it is possible by a FTL51 to create a larger room with a sensor length of 115 mm.

Circuit diagram

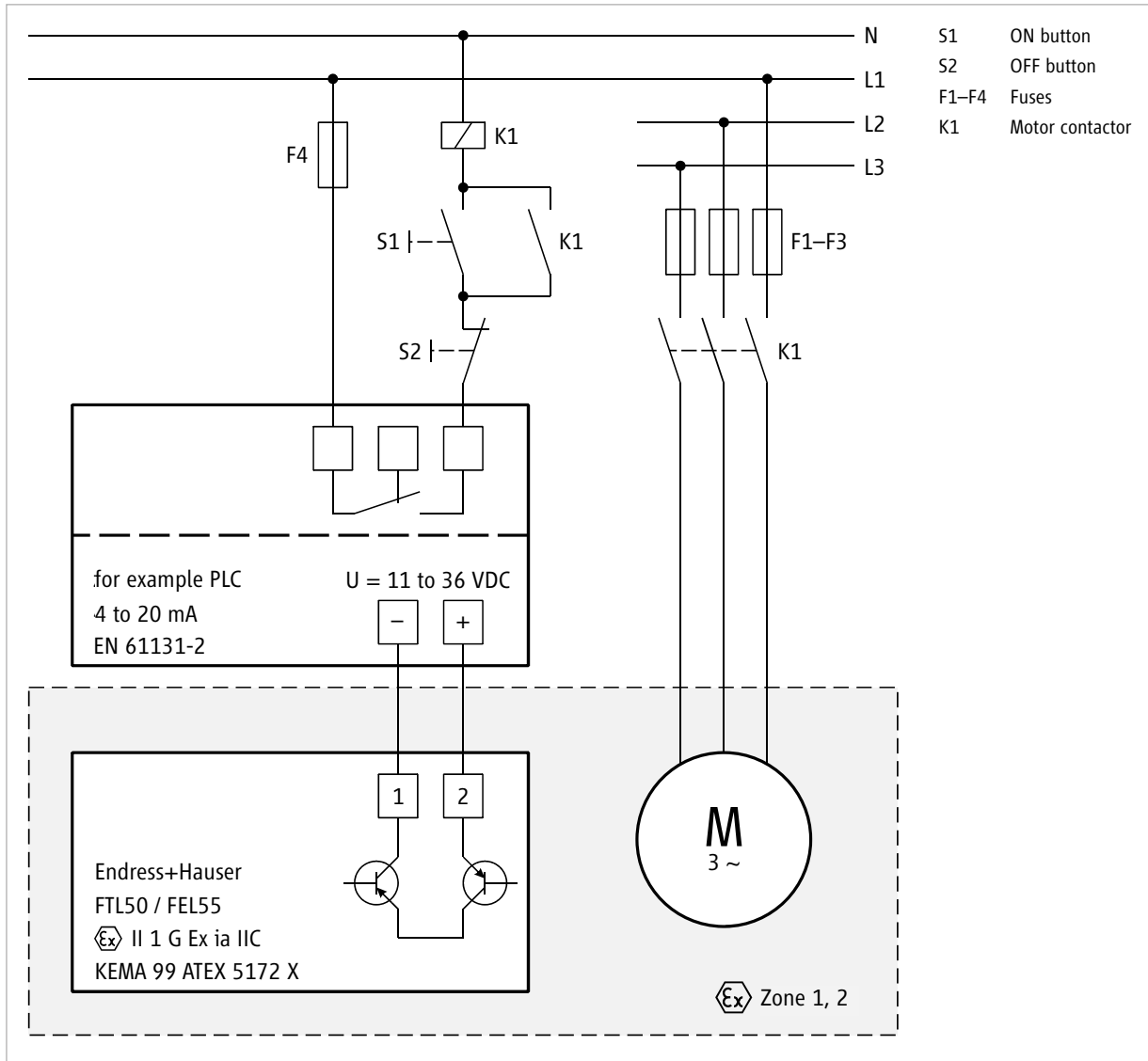

Example of a connection involving the FTL50 / FEL55

Exemplary drawing. Contains components that can be quoted on request but are not necessarily included in your individual quotation.

The monitoring device should be at least as high as the discharge nozzle of the pump. For boiling liquids (liquid gases) and when used as protection against dry running, the device must be fitted so that the dimension NPSHp + 0.5 m holds. There must be no shut-off device between the float and the suction nozzle.

HDE-DB-7.2.3-FLT-EN-00/2016

All details as stated in this document comply with the technical standard that is applicable at the date of printing. These details are subject to technical innovations and modifications at any time.



HERMETIC-Pumpen GmbH  
 Gewerbestrasse 51 · D-79194 Gundelfingen  
 phone +49 761 5830-0 · fax +49 761 5830-280  
 hermetic@hermetic-pumpen.com  
 www.hermetic-pumpen.com

## Liquid temperature monitoring

### Function

The PT100 resistance thermometer of type TR55 (type TR10-L, Ex d, for installation in a thermowell) has been optimally designed for measuring surface temperatures with dry ambient conditions at the measuring tip. The spring-loaded, flat design of the measuring tip ensures a uniform contact pressure of the thermometer. The optimal insertion depth can be set via a threaded clamp. Optionally installed transmitters (analogue or digital) in the connection head are capable of providing different output signal types (4-20 mA, HART® protocol).

### Model / Type

Manufacturer: WIKA Alexander Wiegand SE & Co.KG

- TR55 resistance thermometer with spring-loaded measuring tip
- TR10-L, Ex d resistance thermometer, for installation in a thermowell

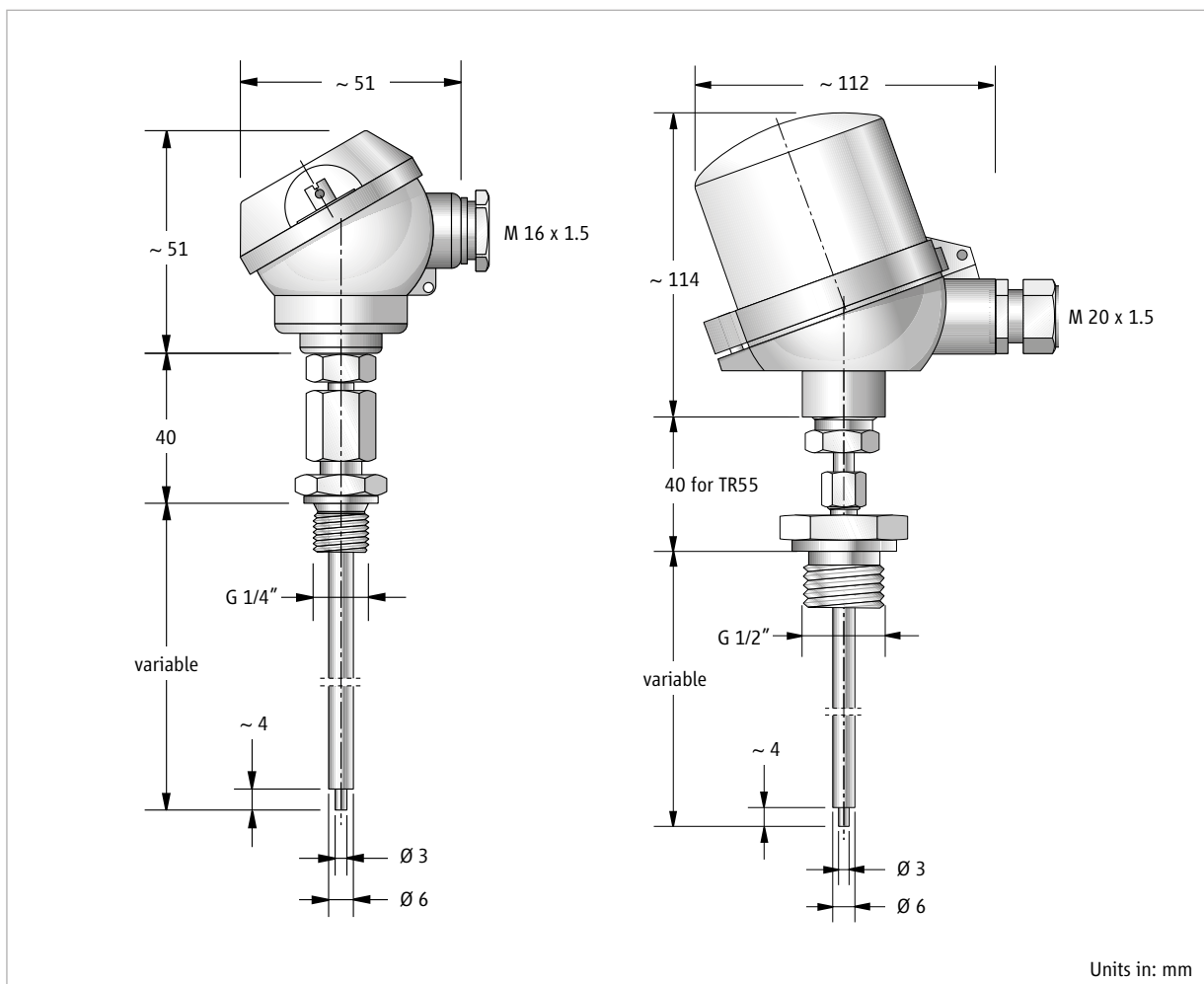

Model TR55

**Explosion protection according to Directive 94/9/EC**

EC-type-examination certificate TÜV 10 ATEX 555793 X

EN 60079-0: 2006, EN 60079-11: 2007, EN 60079-26: 2004, EN 61241-0: 2006, EN 61241-11: 2004

Resistance thermometer with head transmitter: SIL 2

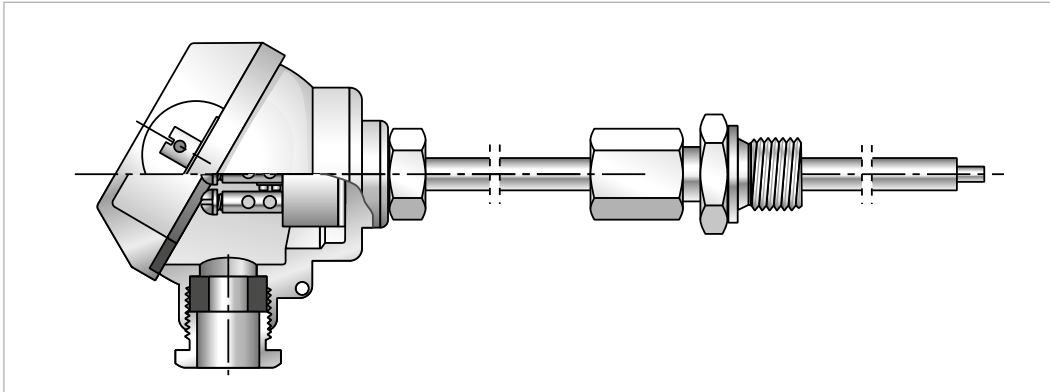
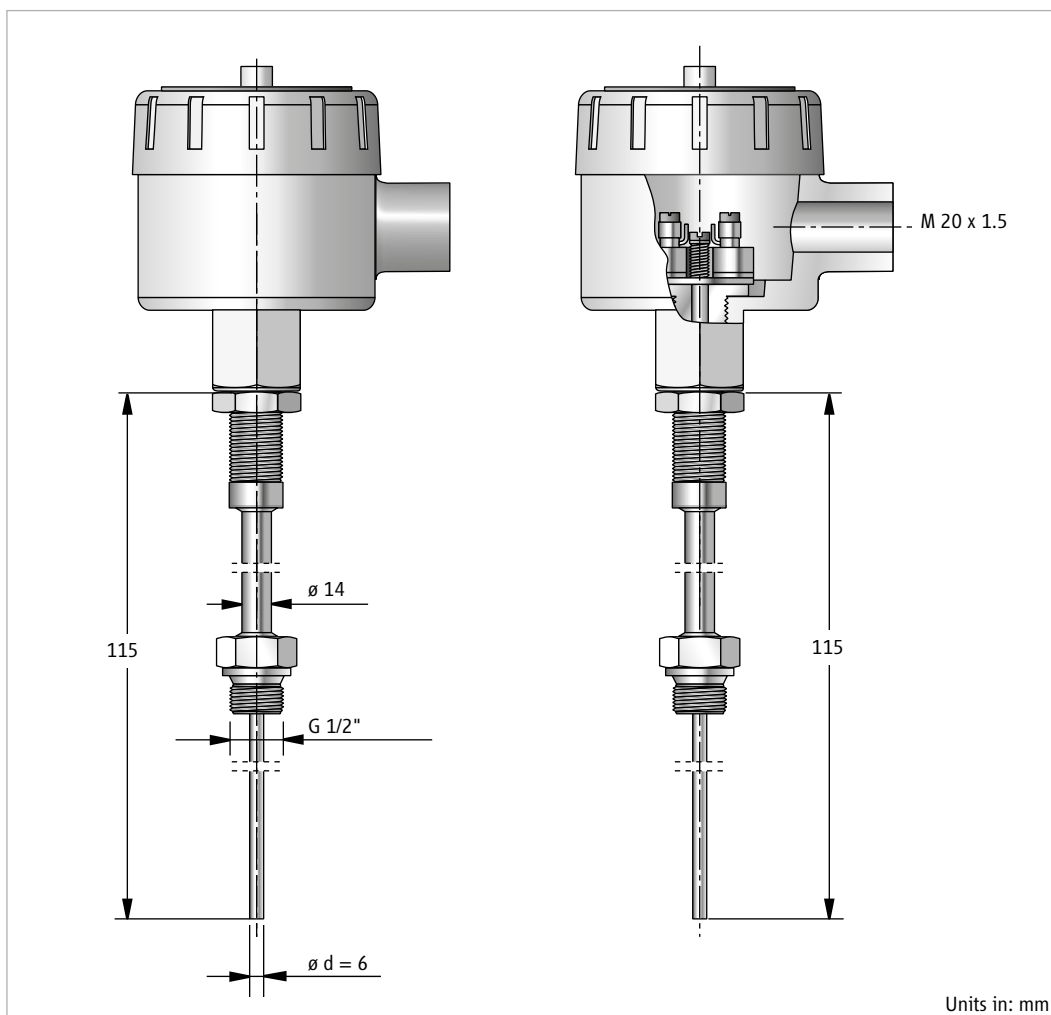
**TR55 components****TR10-L components**



**Design**

PT100 resistance thermometer model	Mat. no.	Certification, Ex i	Process connection	Support tube	Head transmitter	Cable connection
TR55	266240336	ATEX II 1/2GD Ex ia IIC T3..T6/IECEx Zone0/1	G 1/2" Connection piece, 19447	60 mm	Digital Transmitter, HART® Protokoll	M20x1.5
TR55	266240526	ATEX II 1/2GD Ex ia IIC T3..T6/IECEx Zone0/1	G 1/2" Connection piece, 19447	60 mm	–	M16x1.5
TR55	266240386	ATEX II 1/2GD Ex ia IIC T3..T6/IECEx Zone0/1	G 1/4"	75 mm	Digital Transmitter, HART® Protokoll	M20x1.5
TR55	266240451	ATEX II 1/2GD Ex ia IIC T3..T6/IECEx Zone0/1	G 1/4"	95 mm	Digital Transmitter, HART® Protokoll	M20x1.5
TR55	266240400	ATEX II 1/2GD Ex ia IIC T3..T6/IECEx Zone0/1	G 1/4"	75 mm	–	M20x1.5
TR55	266240409	ATEX II 1/2GD Ex ia IIC T3..T6/IECEx Zone0/1	G 1/4"	95 mm	–	M20x1.5

PT100 resistance thermometer model	Mat. no.	Certification, Ex d	Process connection	Support tube	Head transmitter	Cable connection
TR10-L	266240312	ATEX II 1/2GD Ex d IIC T3..T6/IECEx Zone0/1	G 1/2" Connection piece, 19447	60 mm	Digital Transmitter, HART® Protokoll	M20x1.5
TR10-L	266210447	ATEX II 1/2GD Ex d IIC T3..T6/IECEx Zone0/1	G 1/2" Connection piece, 19447	60 mm	–	M20x1.5

Support tube material: CrNi steel, 1.4571

Head material: Aluminium

Electrically-connected element: 1xPT100 (3-wire) sensor

**Temperature range**

TR55: –50 °C to +450 °C

TR10-L: –200 °C to +500 °C

**Electrical data (transmitter not included)**

Protection intrinsically safe ([Ex ia] IIC), only to be connected to a certified intrinsically safe circuit with the following associated maximum values:  $U_i = DC 30 V$ ;  $I_i = 550 mA$ ;  $P_i = 1.5 W$

**Electrical data**

Protection intrinsically safe ([Ex ia] IIC), only to be connected to a certified intrinsically safe circuit with the following associated maximum values:  $U_i = DC 30 V$ ;  $I_i = 130 mA$ ;  $P_i = 800 mW$

**Trigger device for PT100 resistance thermometer****Model / Type**

Manufacturer: Pepperl+Fuchs GmbH

KFU8-GUT-Ex1.D [wide-AC/DC-range supply unit], mat. no. 265931206

KFD2-GUT-Ex1.D [24-VDC supply unit (with power rail)], mat. no. 265931207

**Explosion protection according to Directive 94/9/EC**

EC-type examination certificate TÜV 03 ATEX 2140

EN 60079-0:2006

EN 60079-11:2007

EN 60079-26:2007

EN 61241-0:2006

EN 61241-11:2006

**Installation**

The device must be installed outside the hazardous zone. The only action required is to connect a three-wire signal line to the PTC resistor relay.

**Electrical data**

Contact type: SPDT  
Max. switching voltage: 250 VAC  
Max. switching current: 2 A  
Interface current: 4-20 mA

Max. line resistance: 50 Ω

**Mechanical data**

Dimensions: 40 x 119 x 115 mm (C3 casing)  
Fastening: Attached to 35-mm standard rail in accordance with EN 50 022  
Weight: Approx. 300 g  
Permissible ambient temperature range: -20 °C to +60 °C  
Protection rating: IP 20

Circuit diagram

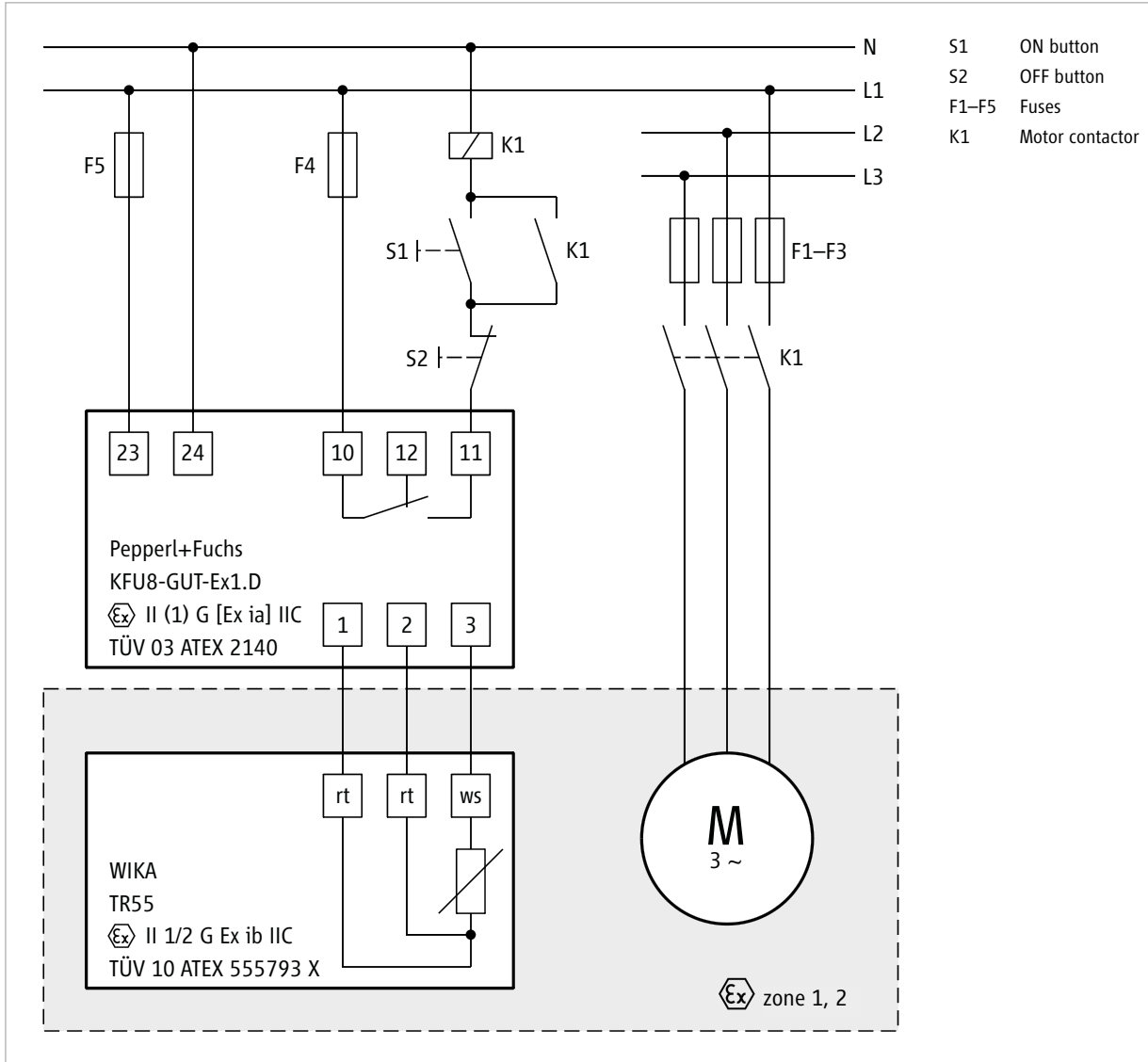

Example of a connection

Exemplary drawing. Contains components that can be quoted on request but are not necessarily included in your individual quotation.

HDE-DB-7.2.3-PT100-EN-00/2016

All details as stated in this document comply with the technical standard that is applicable at the date of printing. These details are subject to technical innovations and modifications at any time.



HERMETIC-Pumpen GmbH  
 Gewerbestrasse 51 · D-79194 Gundelfingen  
 phone +49 761 5830-0 · fax +49 761 5830-280  
 hermetic@hermetic-pumpen.com  
 www.hermetic-pumpen.com

## Thermal motor protection

### Function

The thermal motor protection protects the canned motor from excessive winding temperatures caused by mechanical overloading or by the failure of one or two phases. Therefore, motor are equipped with temperature probes in each winding phase. PT100 resistance thermometers for motors with insulation class C-220 up to 210 °C and C-400 windings up to 380 °C or PTC thermistors, with a nominal response temperature of 180 °C for motors with insulation class H, are available for canned motors.

Since the temperature of the motor winding is directly monitored, this protective device is independent of the type of current and connection. Hence, along with the utilisation of the thermal motor protection, the operation of the canned motor pump in combination with a frequency converter and the connection to a motor standstill heater in potentially explosive atmospheres, are also permissible.

### For evaluating the signals we offer the following devices:

#### Model / Type

Manufacturer: ZIEHL industrie-elektronikGmbH+Co KG

- PTC resistor relay of type MS 220 KA, AC 220–240 V  $\pm 10$  %, 50/60 Hz  $\leq 2$  VA, 1 changeover contact, mat. no. 265940700
- PTC resistor relay of type MS 220 KA, AC/DC 24 V, AC  $\pm 10$  % 50/60 Hz, DC 21–30 V  $\leq 2$  VA, without electrical isolation, 2 changeover contact, mat. no. 265940701

### Explosion protection according to Directive 94/9/EC

EC-type examination certificate PTB 02 ATEX 3058

EN 61000-6-4: 2007, EN 61000-6-2: 2005, EN 60947-5-1: 2004, EN 60947-8: 2003, EN 60079-14: 2003

### Installation

The device must be installed outside the ex zone. The only action required is to connect a two-wire signal line to the PTC resistor relay.

### Electrical data

Contact type:	1 changeover contact / 2 changeover contact
Max. switching voltage:	400 VAC
Max. switching current:	5 A

### Max. cable length

1000 m for cross-sectional area of 2.5 mm<sup>2</sup>

### Mechanical data

Dimensions:	75 x 22.5 x 110 mm
Fastening:	Attached to 35 mm standard rail in accordance with EN 50 022 or via M4 screws
Weight:	Approx. 150 g
Fitting position:	Any
Permissible ambient temperature range:	-20 °C to +55 °C
Protection rating of housing:	IP 30
Protection rating of terminals:	IP 20

Circuit diagram

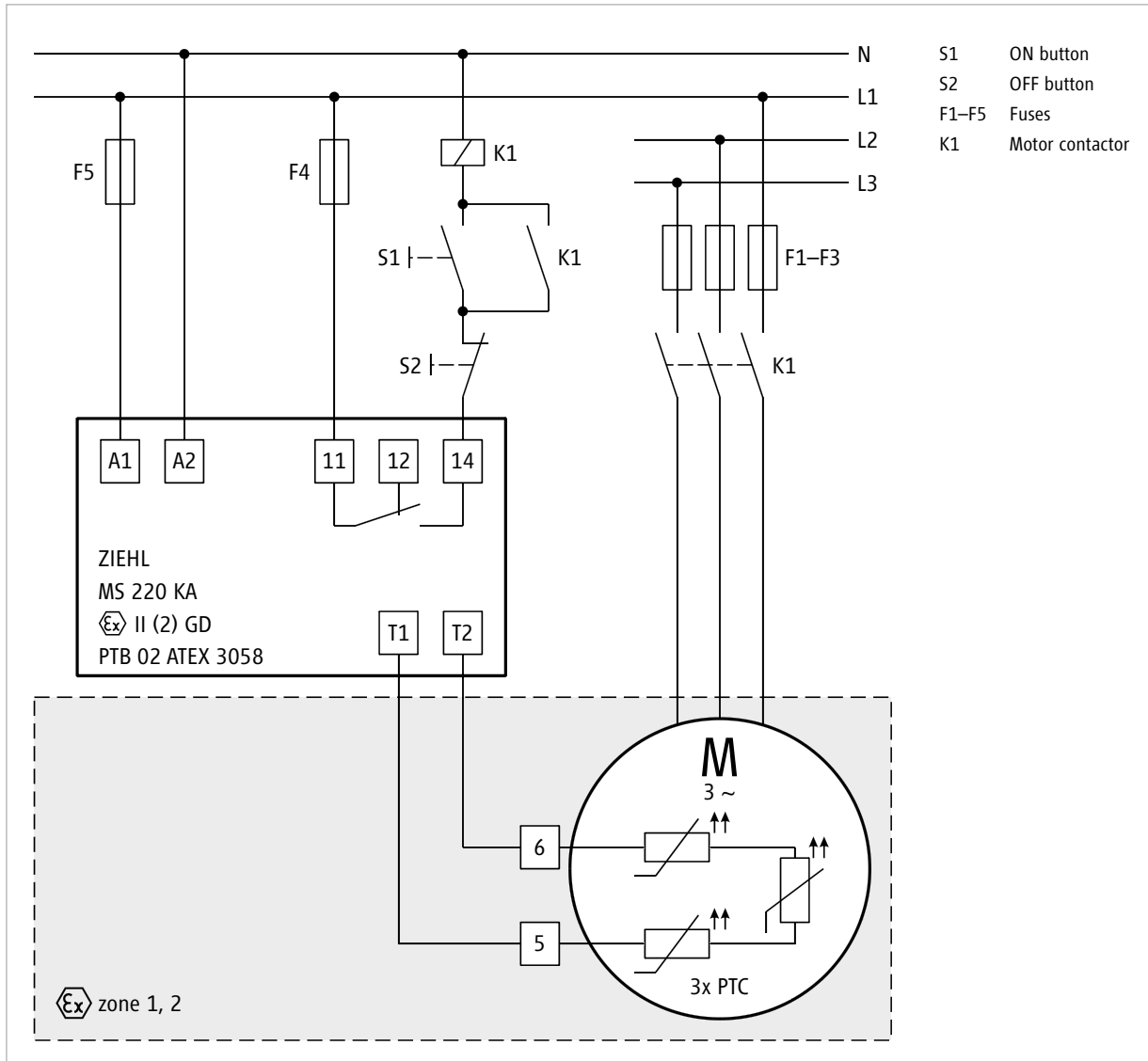

Example of a connection involving a triple PTC thermistor

Exemplary drawing. Contains components that can be quoted on request but are not necessarily included in your individual quotation.

**Trigger device for PT100 resistance thermometer****Model / Type**

Manufacturer: Pepperl+Fuchs GmbH

KFU8-GUT-Ex1.D [wide-AC/DC-range supply unit], mat. no. 265931206

KFD2-GUT-Ex1.D [24-VDC supply unit (with power rail)], mat. no. 265931207

**Explosion protection according to Directive 94/9/EC**

EC-type examination certificate TÜV 03 ATEX 2140

EN 60079-0:2006, EN 60079-11:2007, EN 60079-26:2007, EN 61241-0:2006, EN 61241-11:2006

**Installation**

The device must be installed outside the hazardous area. The only action required is to connect a three-wire signal line to the PTC resistor relay.

**Electrical data**

Contact type:	SPDT
Max. switching voltage:	250 VAC
Max. switching current:	2 A
Interface current:	4–20 mA

**Max. line resistance**

50 Ω

**Mechanical data**

Dimensions:	40 x 119 x 115 mm (C3 casing)
Fastening:	Attached to 35 mm standard rail in accordance with EN 50 022
Weight:	Approx. 300 g
Permissible ambient temperature range:	–20 °C to +60 °C
IP Protection class:	IP 20

Circuit diagram

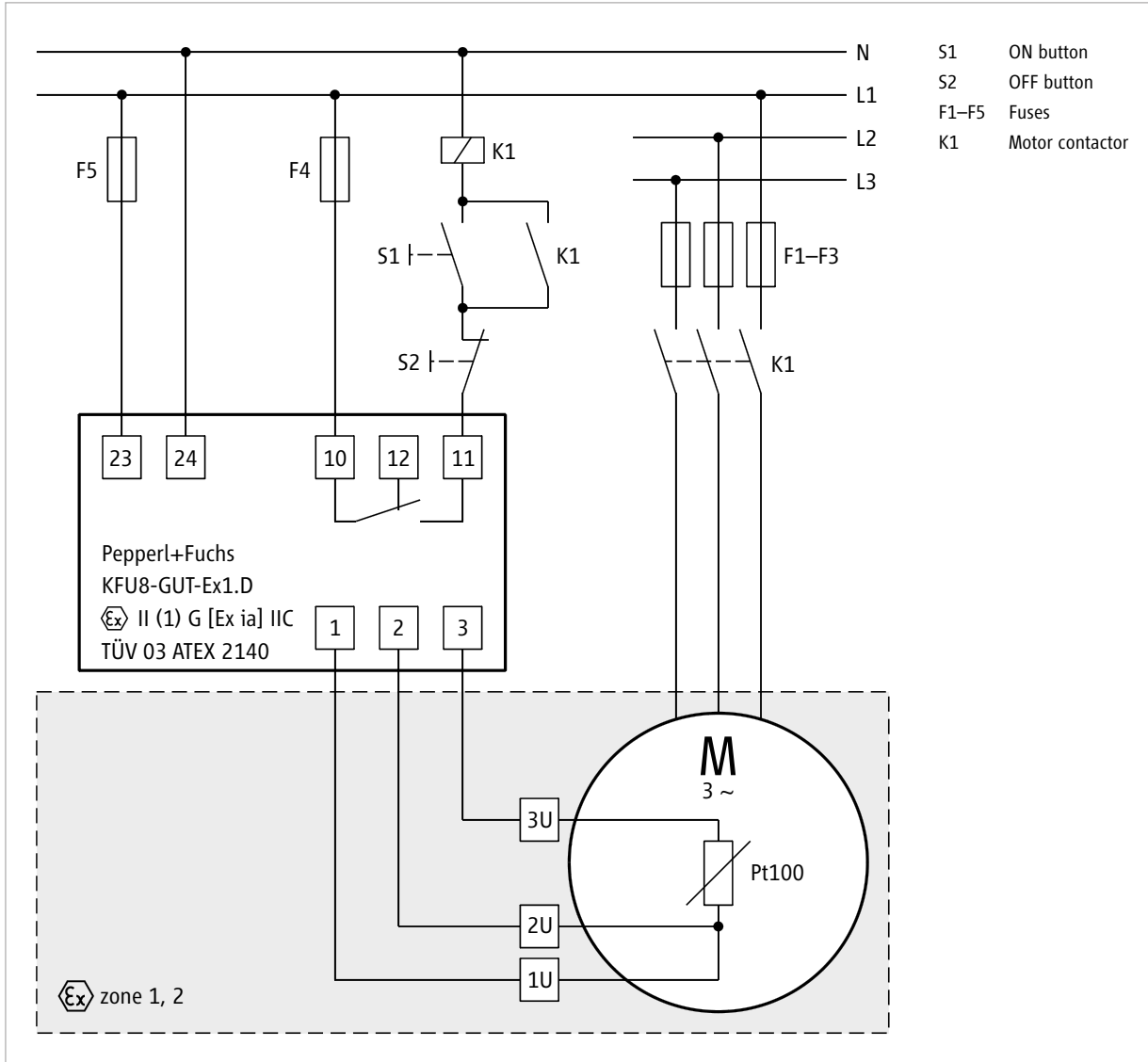

Example of a connection involving a 3-wire PT100 resistance thermometer (with U denoting winding strand)

Exemplary drawing. Contains components that can be quoted on request but are not necessarily included in your individual quotation.

## Rotor position monitoring

### Function

The Monitor for Axial Position (MAP) is a contact free measuring device based on the LVDT (Linear Variable Differential Transformer) principle for monitoring the axial shaft position of a HERMETIC pump. The MAP consists of a sensor assembly with a permanently attached sensor cable and a separate controller unit mounted in a Fibreglas reinforced polyester casing of protection type IP65. A chemically resistant pin is mounted to the shaft end of the pump rotor. The pin contains a ferromagnetic core which is hermetically enclosed by seal welding. The installed and rotating pin extends at the back end of the pump. A modified cover (hub flange) is flanged to the pump and seals the pin from the atmosphere. The sensor is mounted to this cover. This arrangement allows the contact free measurement of the axial displacement of the pump shaft to ensure that the unit remains hermetically sealed. The sensor signal is analyzed by a separate controller which is located up to 5 m (16ft) away from the pump. With the ferromagnetic core of the pin located in the center of the sensor, the MAP will have an output signal of 12 mA. The signal sensitivity is typically adjusted to 2 mA for each mm of movement. The analyser contains trimmers and LEDs to calibrate the output signal.

The system is characterised by the following features:

- Based on the reliable LVDT (Linear Variable Differential Transformer) displacement measuring system
- Independent of rotational speed, i.e. the device can be calibrated when pump is switched-off
- Suitable for frequency converter
- No permanent magnet that attracts ferrite particles
- Sensor and controller are separated. This allows the operation in a wider temperature range
- Easy to install and to calibrate
- Approval for use in potentially explosive atmospheres
- Operating range  $-40^{\circ}\text{C}$  to  $+130^{\circ}\text{C}$ ; cooling fins required for operating temperatures  $>+130^{\circ}\text{C}$

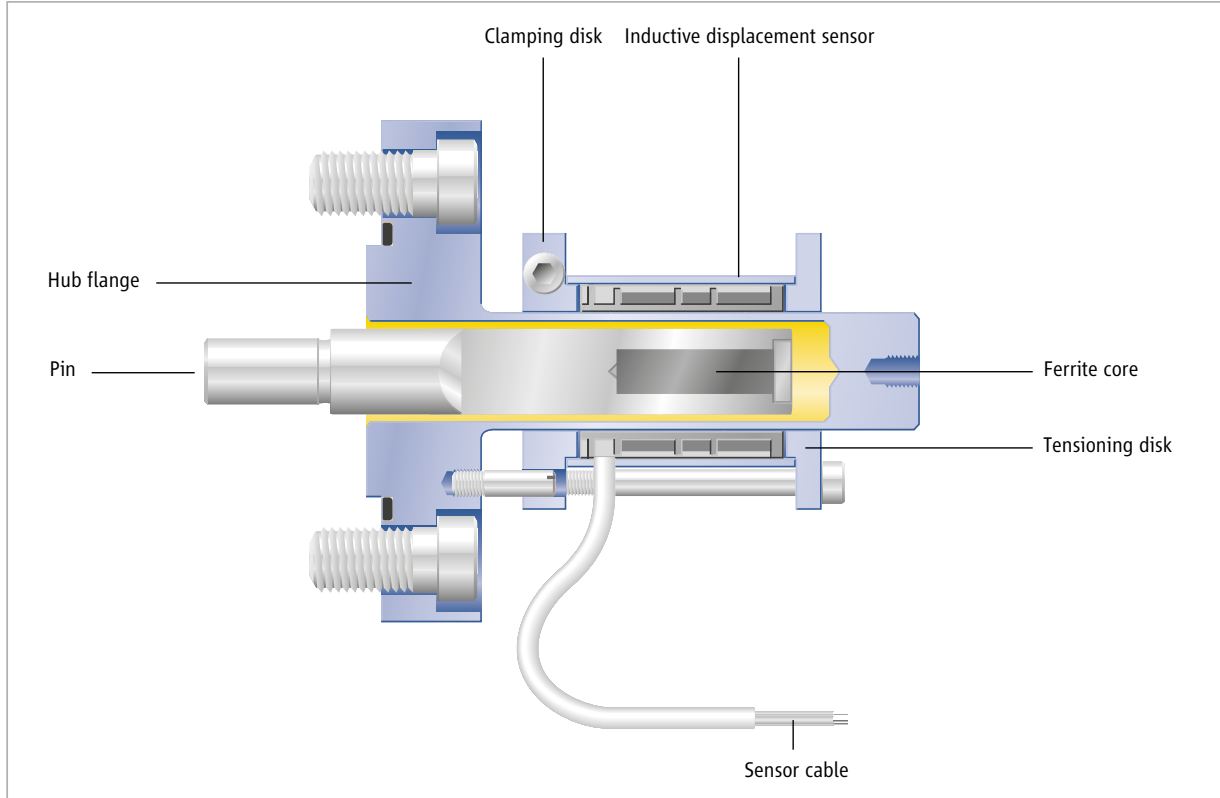



**ATEX version****Sensor DTA-3D-5-CR5-G-HP / mat. no.: 264000026202**

Measuring range:	±3.0 mm
Dimension [mm]:	∅ 38 x 45.5
Housing material:	Materials of wetted parts stainless steel 1.4571 (ASTM A276 type 316Ti)
Weight:	200 g; sensor with cable
Mounting:	Bearing cover
Power supply:	5 m (16 ft) Teflon cable 5xAWG22/7 braided wire ends with end sleeves
Operating temperature:	−40 °C to +130 °C (−40 °F to +266 °F)
Storage temperature:	−40 °C to +130 °C (−40 °F to +266 °F)
Humidity:	5 to 95 % (non-condensing)
Ambient pressure:	atmospheric pressure
Input voltage:	up to 10 V <sub>eff</sub>
Frequency:	0.2 kHz to 20 kHz
Resistance / Inductance (Pin in center position):	primary: 50 Ω / 7.8 mH secondary: 2 x 90 Ω / 21 mH
Linearity:	< 0.5 % of the measuring range at 0.5 V <sub>eff</sub> / 1 kHz
Degree of protection:	IP 66 (DIN 40 050 / IEC 60 529)
Explosion protection marking:	II 2G Ex ib IIC T6 ZELM 09 ATEX 0403 X

only valid with corresponding MAP analyser, mat. no.: 266900204

**MAP controller / mat. no.: 266900204**

Measuring range:	±3.0 mm
Dimension L x W x H [mm]:	122 x 82 x 64
Housing material:	Polyester black (antistatic), reinforced fiberglass
Weight:	550 g
Operating temperature:	−30 °C to +70 °C (−22 °F to +158 °F)
Storage temperature:	−40 °C to +85 °C (−40 °F to +185 °F)
Humidity:	5 to 95 % (non-condensing)
Ambient pressure:	atmospheric pressure
Power supply:	DC 24 V −30 %...+20 % (16.8...28.8 V) < 80 mA
Output signal:	4...20 mA; load resistor max. 500
Sensor signal:	0.5...0.6 V <sub>eff</sub> ; 0.9...1.2 kHz
Linearity:	< 0.5 % of the measuring range at 0.5 V <sub>eff</sub> / 1 kHz
Sensor connection:	allowed ∅ 3.5 to 6 mm; 0.08 to 2.5 mm <sup>2</sup> ; cage clamps
Grounding connection:	allowed ∅ 3.5 to 6 mm; 4 mm <sup>2</sup> ; cable lug
Power supply and signal output connection:	allowed ∅ 5 to 8 mm; 0.5 to 2.5 mm <sup>2</sup> ; cage clamps
Adjustment and signal components:	2 trim pots; 4 LEDs in enclosure
Degree of protection:	IP 65 (DIN 40 050 / IEC 60 529)
Explosion protection marking:	II 2G Ex e mb [ib] IIC T6 ZELM 09 ATEX 0403 X

only valid with corresponding DTA-3D-5-CR5-G-HP sensor, mat. no.: 264000026202

**FM version (US)****Sensor DTA-3D-5-CR5-G-HP / mat. no.: 264000026203**

Measuring range:	±3.0 mm
Dimension [mm]:	Ø 38 x 45.5
Housing material:	Materials of wetted parts stainless steel 1.4571 (ASTM A276 type 316Ti)
Weight:	200 g; sensor with cable
Mounting:	Bearing cover
Power supply:	5 m (16 ft) Teflon cable 5xAWG22/7 braided wire ends with end sleeves
Operating temperature:	−40 °C to +130 °C (−40 °F to +266 °F)
Storage temperature:	−40 °C to +130 °C (−40 °F to +266 °F)
Humidity:	5 to 95 % (non-condensing)
Ambient pressure:	atmospheric pressure
Input voltage:	up to 10 V <sub>eff</sub>
Frequency:	0.2 kHz to 20 kHz
Resistance / Inductance (Pin in center position):	primary: 50 Ω / 7.8 mH secondary: 2 x 90 Ω / 21 mH
Linearity:	< 0.5 % of the measuring ranges at 0.5 V <sub>eff</sub> / 1 kHz
Degree of protection:	IP 66 (DIN 40 050 / IEC 60 529)
Explosion protection marking:	II 2G Ex ib IIC T6 ZELM 09 ATEX 0403 X

only valid with corresponding MAP analyser, mat. no.: 266900203

**MAP controller / mat. no.: 266900203**

Measuring range:	±3.0 mm
Dimension L x W x H [mm]:	176.5 x 116.5 x 101
Housing material:	stainless steel
Weight:	1800 g
Operating temperature:	−30 °C to +55 °C (−22 °F to +131 °F)
Storage temperature:	−40 °C to +85 °C (−40 °F to +185 °F)
Humidity:	5 to 95 % (non-condensing)
Ambient pressure:	atmospheric pressure
Power supply:	DC 24 V −30 %...+20 % (16.8...28.8 V) <80 mA
Output signal:	4...20 mA; Load resistor max. 500 Ω
Sensor signal:	0.5...0.6 V <sub>eff</sub> ; 0.9...1.2 kHz
Linearity:	<0.5 % of the measuring ranges at 0.5 V <sub>eff</sub> / 1 kHz
Adjustment and signal components:	2 trim pots; 4 LEDs in enclosure
Degree of protection:	IP 65 (DIN 40 050 / IEC 60 529)
Explosion protection marking:	II 2G Ex e mb [ib] IIC T6 ZELM 09 ATEX 0403 X

only valid with corresponding DTA-3D-5-CR5-G-HP sensor, mat. no.: 264000026203

**Pin assignment**

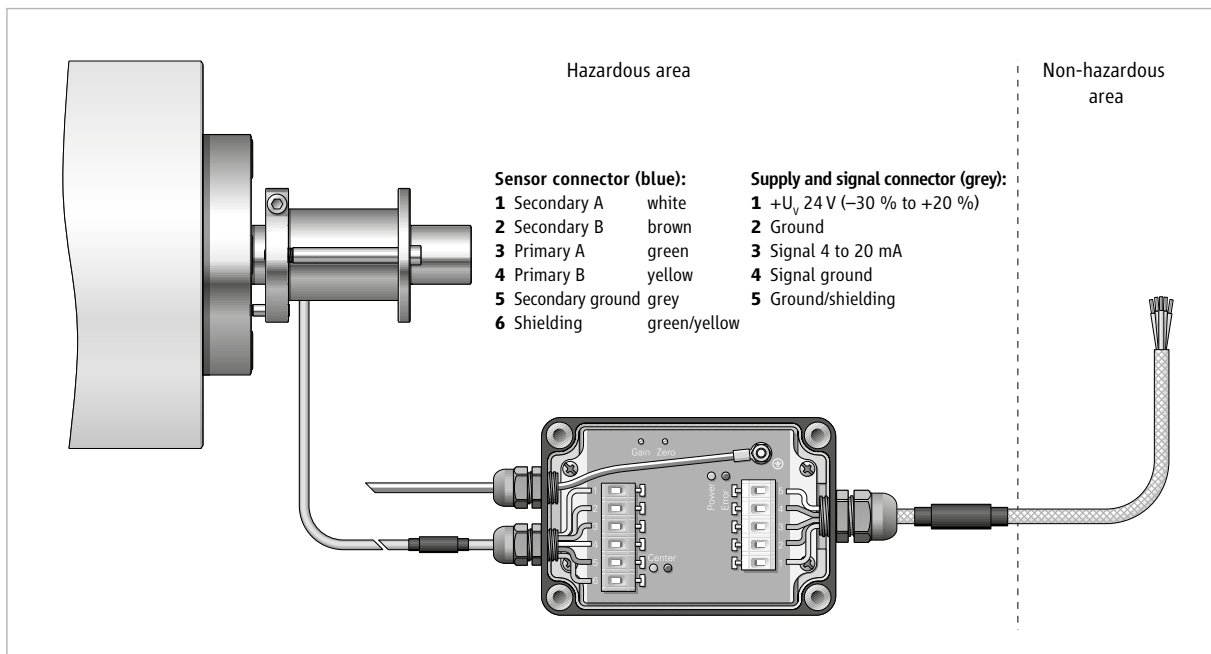

**Installation scheme**

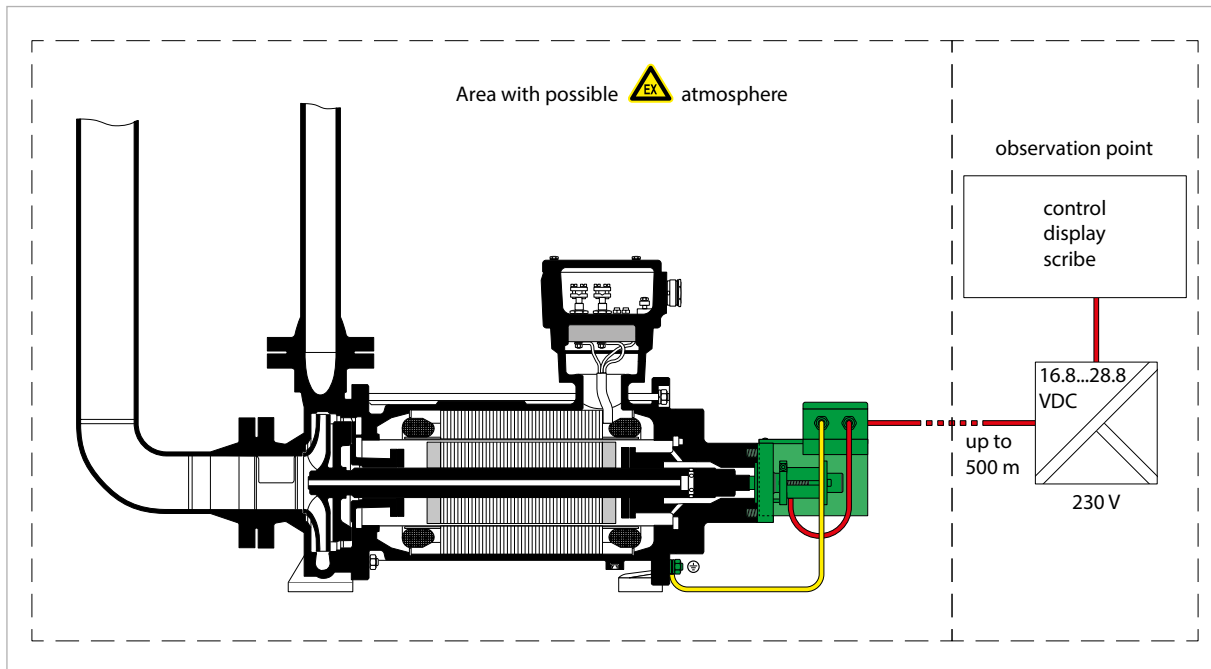

**Function and warning indicators**

LEDs at sensor (blue)

- green signal below 12 mA
- red signal above 12 mA
- red/green changeover pin in mechanical center position (hysteresis approx. 0.06 mA)

LEDs at supply connector (grey)

- green (Power) supply voltage is OK
- red (Error) supply voltage is too low or load resistor in signal circuit is too large

**Circuit diagram**

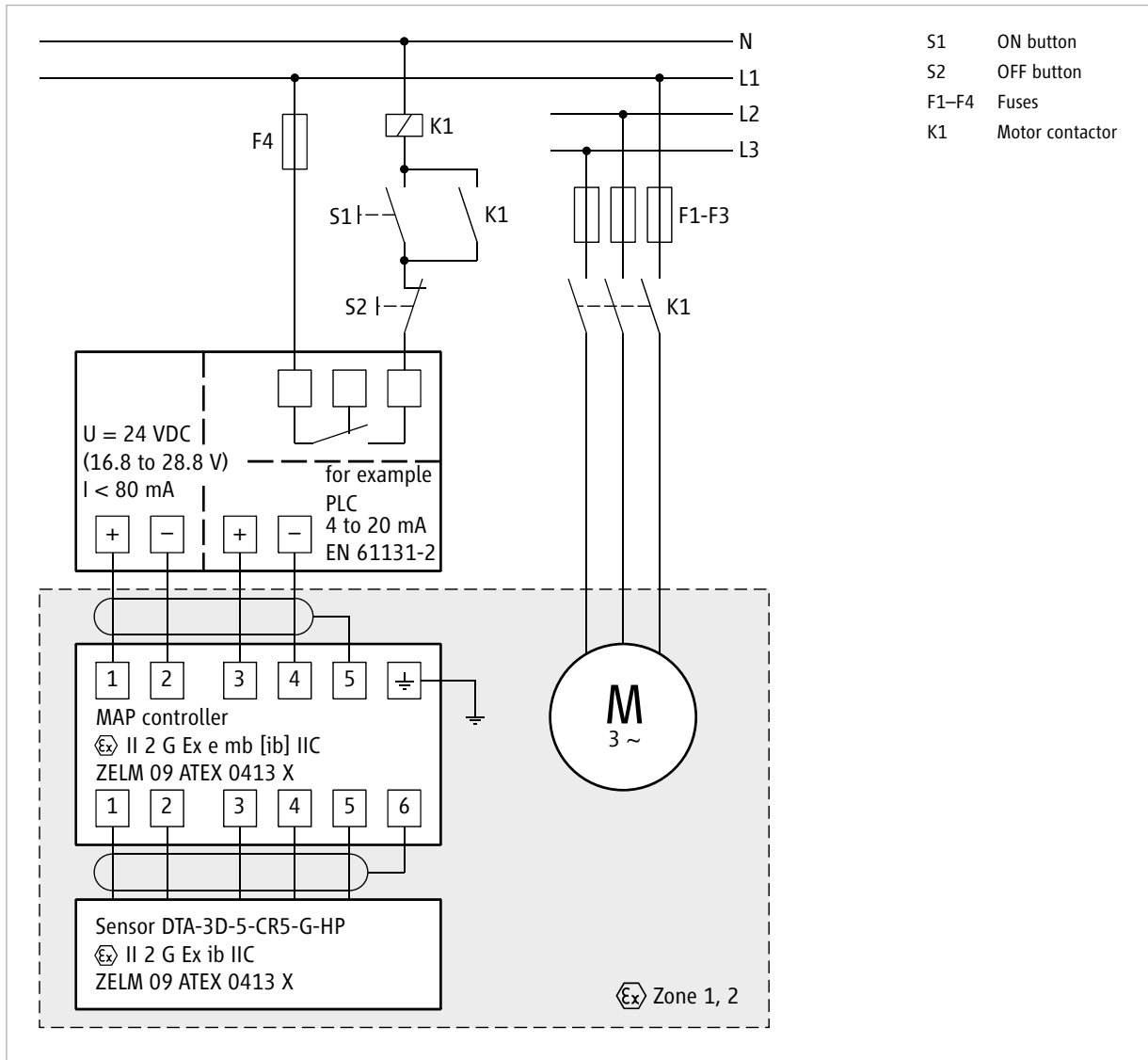

Power supply unit for MAP

Exemplary drawing. Contains components that can be quoted on request but are not necessarily included in your individual quotation

**Model / Type**

Manufacturer: PHOENIX CONTACT Deutschland GmbH

- DIN-rail power supply unit: 24 V DC; type STEP-PS/ 1AC/24DC/0.5; primary-switched; single-phase; mat. no.: 262000012

**Installation**

The device must be installed outside the hazardous area.

**Electrical data**

Input voltage: 100 to 240 V AC; 50 to 60 Hz

Current consumption: Approx. 0.28 A (120 V AC); approx. 0.13 A (230 V AC)

Output voltage: 24 V DC  $\pm 1\%$

Output current: 0.5 A; max 1 A



HDE-DB-7.2.3-MAP-EN-00/2016

All details as stated in this document comply with the technical standard that is applicable at the date of printing. These details are subject to technical innovations and modifications at any time.

HERMETIC-Pumpen GmbH  
Gewerbestrasse 51 · D-79194 Gundelfingen  
phone +49 761 5830-0 · fax +49 761 5830-280  
hermetic@hermetic-pumpen.com  
www.hermetic-pumpen.com

## Rotation monitoring

### Function

For 34-l motors or larger, the following device is installed as standard in the canned motor pump:

- ROMi rotation monitor (integrated): Encapsulated module for installation in stator chamber below terminal box

With the relay output integrated in the monitoring circuit of the pump, an immediate shut-off of the power supply is guaranteed in case of an incorrect phase sequence (and therewith incorrect sense of rotation), due to the short response time of the device.

ROMi rotation monitor, mat. no. 262000010

- Phase sequence module compliant with DIN EN 60255
- Sense of rotation monitoring by detection of incorrect phase sequence
- No separately auxiliary voltage necessary – the power is supplied by the pump motor
- Nominal voltage range: 3 AC, 380 to 690 V
- Suitable for frequency converters (f in range 40-80 Hz)
- Relay output: NC contact (open if phase sequence incorrect), short response time
- Extended temperature range
- Encapsulated module with stranded wire connection mounted in terminal-boxbase section of canned motor

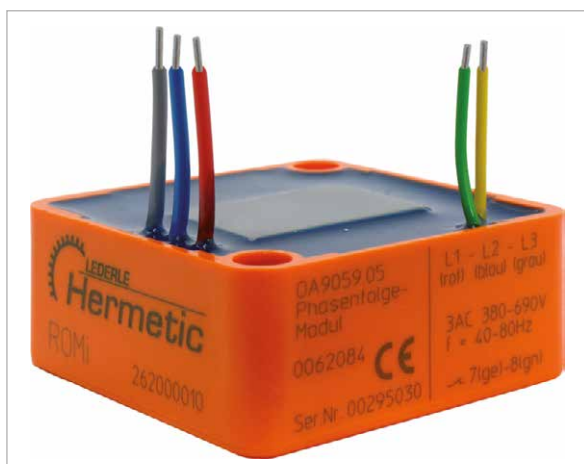

ROMi rotation monitor

### Technical data

#### Input circuit (L1-L2-L3) (ROMi: red, blue and grey stranded wires)

Nominal voltage  $U_N$ : 3 AC, 380 to 690 V

Voltage range: 0.85 to 1.1  $U_N$  (3 AC, 320 to 760 V)

Nominal consumption: Approx. 3 VA

Frequency range: 40 to 80 Hz (fundamental frequency); suitable for frequency converters (no clock-frequency restrictions)

**Output circuit (7-8) (ROMi: yellow and green stranded wires)**

Fitted contact:	1 NC contact	
Response time:	Approx. 100 ms between 3-phase application of nominal voltage in incorrect phase sequence and opening of NC contact	
Thermal current, $I_{th}$		
ROMi:	2 A	
Switching capacity of ROMi		
In acc. with AC 15:	1 A / AC 230 V	IEC/EN 60 947-5-1
In acc. with DC 13:	1 A / DC 24 V	IEC/EN 60 947-5-1
Electrical service life:	1.5 x 10 <sup>5</sup> switching cycles	
Resistance to short-circuiting		
Max. fuse rating		
ROMi:	2 A gL	IEC/EN 60 947-5-1
Mechanical service life:	≥ 30 x 10 <sup>6</sup> switching cycles	
<b>General data</b>		
Nominal operating mode:	Continuous operation	
Temperature range		
ROMi:	-30 °C to +75 °C	
Clearance and creepage distances		
Rated impulse withstand voltage / Pollution degree, output to input:	6 kV / 3	IEC 60 664-1
EMC		
Fast transients:	2 kV	IEC/EN 61 000-4-4
Surge voltages:	2 kV	IEC/EN 61 000-4-5
Interference suppression:	Limit value, class B	EN 55 011
Degree of protection		
ROMi:	encapsuled module	
Housing		
ROMi:	sealing compound with UL approval	
Vibration resistance:	0.35 mm amplitude, frequency in range 10 Hz to 55 Hz	IEC/EN 60 068-2-6
Climatic resistance:		
ROMi:	30 / 075 / 04	IEC/EN 60 068-1

## Wire connection:

ROMi:	L1; stranded wire, red:	0.5 mm <sup>2</sup> , double insulation
	L2; stranded wire, blue:	0.5 mm <sup>2</sup> , double insulation
	L3; stranded wire, grey:	0.5 mm <sup>2</sup> , double insulation
	7; stranded wire, yellow:	0.25 mm <sup>2</sup> , double insulation
	8; stranded wire, green:	0.25 mm <sup>2</sup> , double insulation

## Device dimensions (width x height x depth)

ROMi: 62 x 62 x 28 mm

**Standard types**

ROMi rotation monitor (internal)

Material number: 262000010

- Output: 1 NC contact
- Nominal voltage,  $U_N$ : 3 AC, 380 to 690 V
- Frequency range: 40 to 80 Hz
- Width: 62 mm

**Additional information**

The ROMi rotation monitor may detect an incorrect direction of rotation when using a soft-start device. In this case it may be necessary to bypass the output circuit (7-8) during the start-up procedure for the pump.

In case the motor is additionally equipped with a PTC thermistor, the ROMi rotation monitor can be monitored both separately (7-8) and via the series connection with the PTC thermistor (5-8):

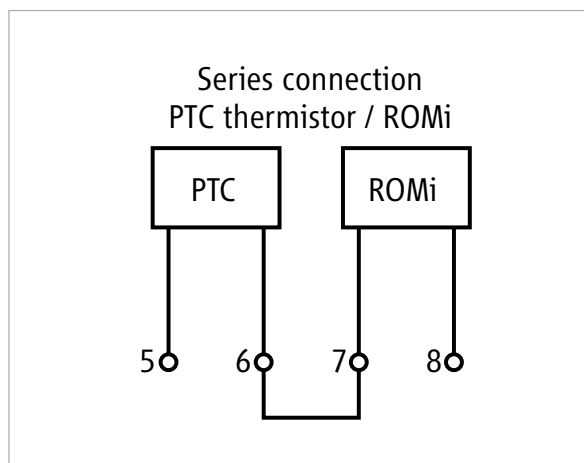

Circuit diagram

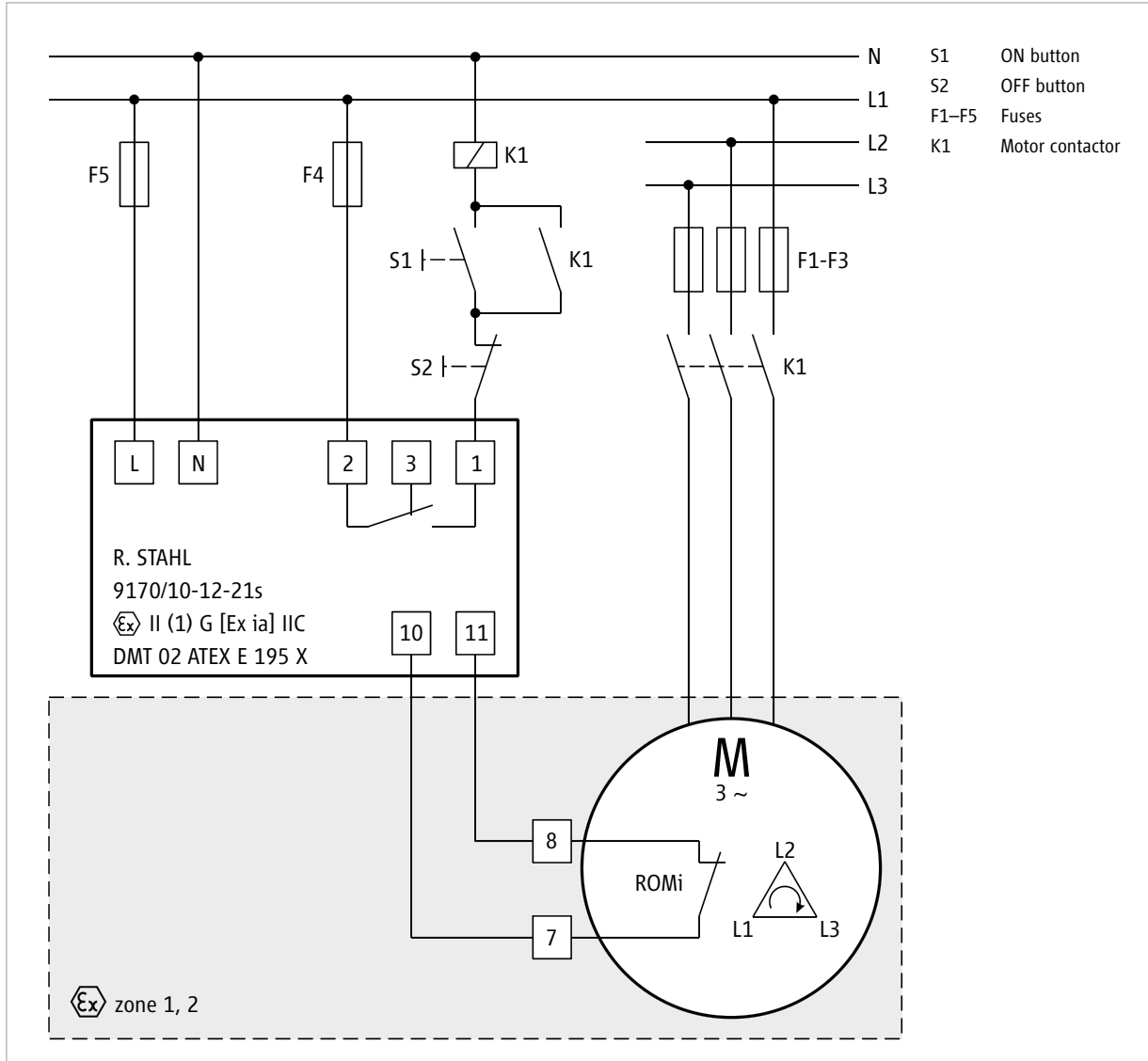

Example of a connection involving the ROMi

Exemplary drawing. Contains components that can be quoted on request but are not necessarily included in your individual quotation.

HDE-DB-7.2.3-ROMI-EN-00/2016

All details as stated in this document comply with the technical standard that is applicable at the date of printing. These details are subject to technical innovations and modifications at any time.



HERMETIC-Pumpen GmbH  
Gewerbestrasse 51 · D-79194 Gundelfingen  
phone +49 761 5830-0 · fax +49 761 5830-280  
hermetic@hermetic-pumpen.com  
www.hermetic-pumpen.com



# Diaphragm pressure switch for pressure monitoring

## Function

If pumped liquid enters the stator chamber due to a damaged stator liner, the pressure acts on the diaphragm (1) of the installed pressure switch. If the force resulting from this pressure is greater than the force exerted by the preloaded compression spring (2), the swivel contact (4) is operated by the plunger (3). By turning the set screw (5), the pressure switch can be adjusted within its pressure range. In a depressurised state, the circuit is closed via the NC contact (6). If the applied pressure exceeds the set switching pressure, the swivel contact is flipped and the circuit closed via the NO contact (7).

Suitable for canned motors in type of protection flameproof enclosure "d" according to EN 60079-1.

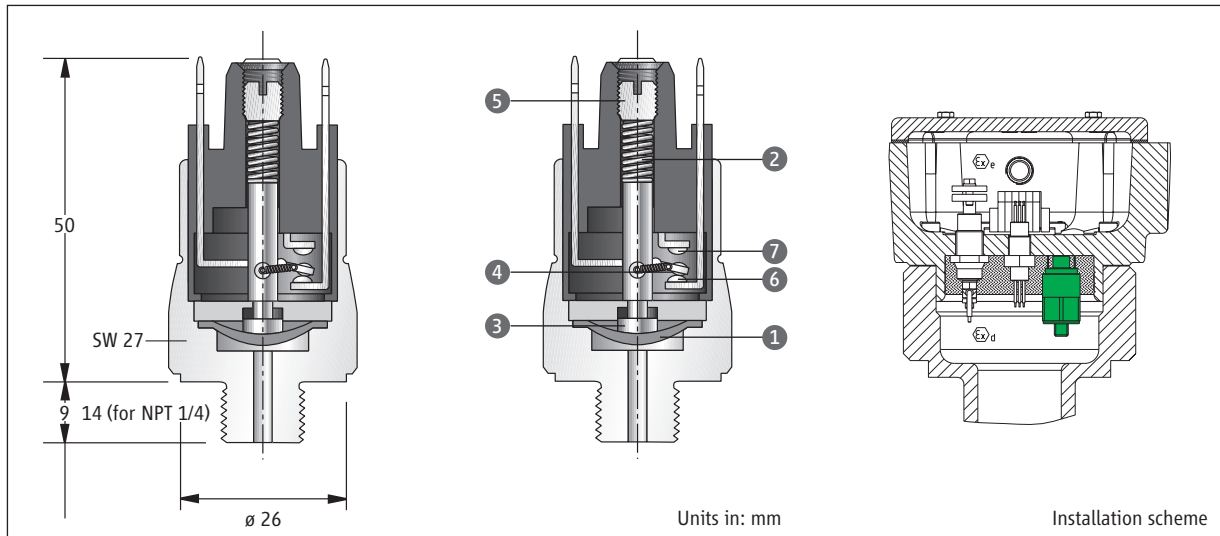

## Model / Typ

Manufacturer: SUCO Robert Scheuffele GmbH & Co. KG

■ Diaphragm pressure switch, SW 27, 24 V DC; type: 0190-458 03-2-042 (HERMETIC mat. no. 26620019)

## Technical data

Setting range:	1 to 10 bar
Tolerance:	0.5 bar
P <sub>max</sub> :	300 bar
Thread:	G 1/4
Material:	Zinc-plated steel
Diaphragm:	EPDM or silicone
Operating temperature:	-30 °C to +120 °C (EPDM)
Degree of protection:	IP 65
Switch:	Pressure- and vacuum-tight
Voltage:	24 V DC
Max. current:	50 mA
Contact configuration:	Changeover switch; connected as NC contact by default



HDE-DB-7.2.3-SUCO-EN-00/2016

All details as stated in this document comply with the technical standard that is applicable at the date of printing. These details are subject to technical innovations and modifications at any time.

HERMETIC-Pumpen GmbH  
 Gewerbestrasse 51 · D-79194 Gundelfingen  
 phone +49 761 5830-0 · fax +49 761 5830-280  
 hermetic@hermetic-pumpen.com  
 www.hermetic-pumpen.com

# PRESSURE TRANSMITTER A-10

## Function

If pumped liquid enters the stator chamber due to a damaged stator liner, the pressure transmitter gets pressurized.

The pressure transmitter converts this pressure into a 4-20mA signal.

Suitable for canned motors in type of protection flameproof enclosure "d" according to EN 60079-1.

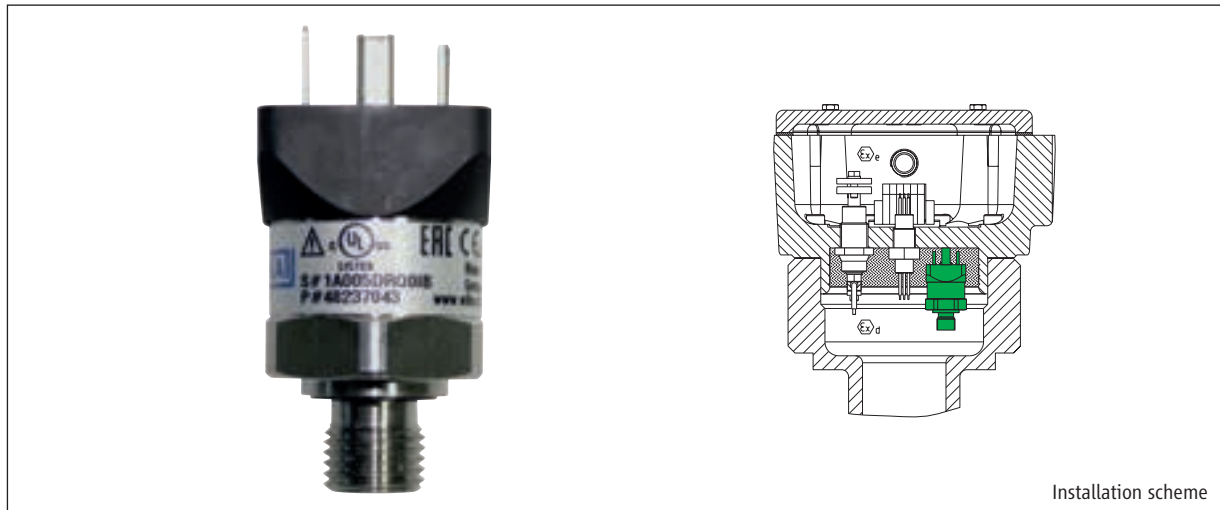

## Model / Type

Manufacturer: WIKA Alexander Wiegand SE & Co. KG

■ Pressure transmitter A-10 (HERMETIC Mat. 260064076)

## Technical data

Measuring range:	0 to 40 bar
Non-linearity:	+/- 0,5 %
pmax:	80 bar
Thread:	G 1/4
Material:	CrNi steel 316L
Operating temperature:	-30 °C to +100 °C
Output:	4 – 20 mA, 2 wire

## CE conformity

**Pressure equipment directive** 97/23/EC

## EMC directive

2004/108/EC, EN 61326 emission (group 1, class B) and immunity (industrial application)

## Approvals

**cULus**, safety (e.g. electr. safety, overpressure, ...),

USA, Canada

**GOST-R**, import certificate, Russia

**GL**, ships, shipbuilding (e.g. offshore), Germany



HDE-DB-7.2.3-WIKA-EN-00/2016

All details as stated in this document comply with the technical standard that is applicable at the date of printing. These details are subject to technical innovations and modifications at any time.

HERMETIC-Pumpen GmbH  
 Gewerbestrasse 51 · D-79194 Gundelfingen  
 phone +49 761 5830-0 · fax +49 761 5830-280  
 hermetic@hermetic-pumpen.com  
 www.hermetic-pumpen.com