

Eclipse

Non-Metallic External Gear Pump

Pulsafeeder Expertise

Since 1936, Pulsafeeder has been the global leader in fluid handling technology and innovation in chemical dosing. Pulsafeeder continues to deliver innovative solutions through a dedication to world-class design, application and systems integration expertise. The highest quality engineering precision and dependability is designed into each product manufactured by Pulsafeeder to maximize performance and ensure global customer satisfaction.

Eclipse® Gear Pumps

The Eclipse Series represents a dramatic advance in pump technology. Combining proven design principles with state of the art engineered composites, the Eclipse Series is the most reliable, simple, and intuitive pump on the market today. Structurally rugged with corrosion-resistant materials, the Eclipse is an ideal fit for many medium to highly corrosive liquids used in the chemical processing, petrochemical, and water treatment industries.

Product Specifications

- Flows to 33 gpm (125 lpm)
- Differential pressures to 150 psi (10.3 bar)
- Maximum pressure 200 psi (13.8 bar)
- Viscosity up to 10,000 cPs
- Temperatures from -40°F to 150°F (-40°C to 65°C)
- 2 feet NPSHR
- 10:1 turndown standard, 20:1 turndown and higher with the MPC Vector

Materials of Construction

- Housings: Carbon-Reinforced ETFE or PVDF
- Magnet: Neodymium Encapsulated in Virgin ETFE
- Gears and Liner: Carbon Reinforced PTFE
- Shafts: Alumina Ceramic
- Bearings: Carbon Graphite or Graphite-Impregnated Silicon Carbide
- O-rings: Viton or EPDM standard, others available

Typical Applications

- Acids
- Solvents
- Caustics
- Polymers
- Bleaches
- Dyes/Inks
- pH Control
- Catalyst
- Cleaning Agents
- And many more

Eclipse Family

Fluid Viscosity: 1 CPS 1750 RPM

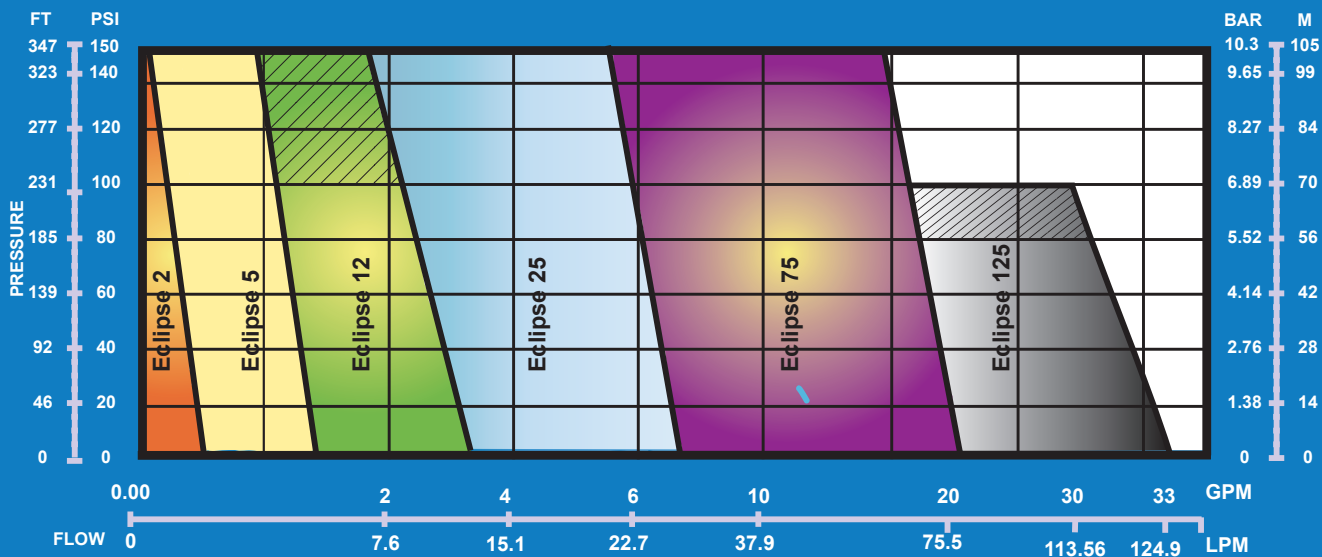

Denotes Silicon Carbide Bearings Only

Non-Metallic Gear Pump Technology

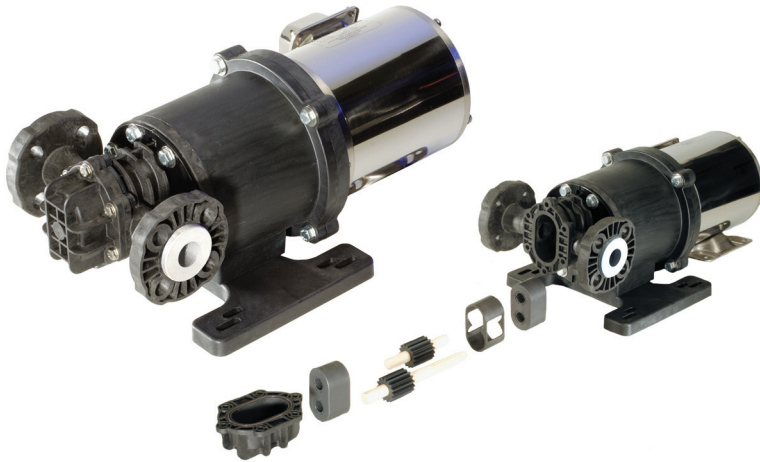

The patent pending carbon bearing design promotes constant lubrication during temporary periods of run dry that can occur in situations such as gas bubbles in the supply line.

The innovative technology behind the Eclipse supports its ability to handle the most corrosive chemicals and materials that are typically handled by heavier, more expensive high alloy pumps. All wetted components of the Eclipse are completely non-metallic. Pump housings and gears are manufactured out of Engineered Fluoropolymers. These Fluoropolymers offer superior corrosion resistance over a broad range of temperatures and chemicals. The Eclipse is magnetically driven so there are no mechanical seals to wear or leak dangerous chemicals.



Eclipse Configurations

The Eclipse pumps are available in many different sizes to meet any flow requirement need. Pictured below: Eclipse Model 2, Model 25 and Model 125.



Features & Benefits



Designed for Simplicity

- Only 16 total parts on the Eclipse verses 40+ on typical metallic pumps
- Fewer parts and material options provide simplified ordering and inventory
- Self-aligning parts and piloted fits ensure proper assembly every time



Renewable Performance

- Patent pending housing liner protects the housing from wear
- Regain as-new performance or increase flow with the change of a KOPkit®
- Keeps pump running at optimal performance and efficiency



Heavy Duty Bearings and Tolerance O-Ring

- Bearings have large wear areas
- Carbon Bearings are made from self-lubricating materials and their patent pending geometry allow for run dry capabilities
- Tolerance O-ring maintains proper internal clearances, tolerant of axial part wear or thermal expansion

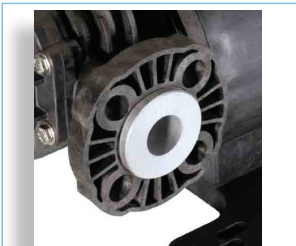

Universal Flanges with PTFE Inserts

- Standard housings mate to both ANSI and DIN flange connections
- PTFE inserts act as a gasket and can be reused or replaced to ensure a proper seal

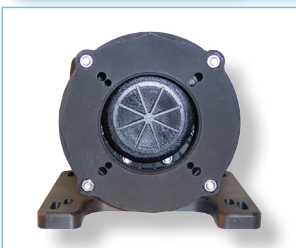

Universal Motor Adaptor

- Standard adapters easily mate to multiple NEMA and IEC motors
- Eliminates the guesswork of choosing “the right” adaptor



Close-Coupled Mounting

- Eliminates the potential for damage due to misalignment
- Helps to eliminate replacement costs due to wear and tear from misalignment

Eclipse Components

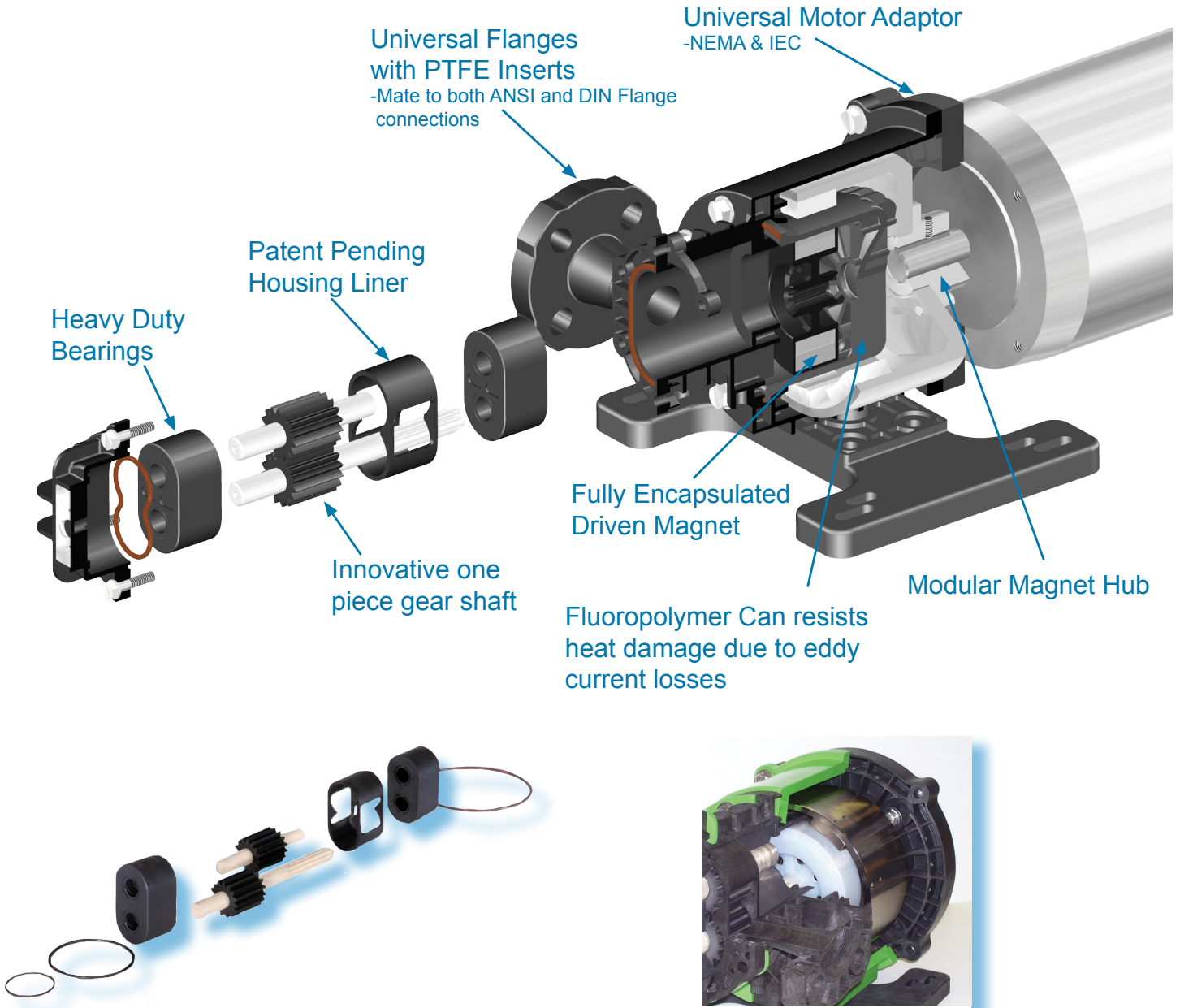

Front-Pull Out Design

- Easily serviced in place without disturbing piping or electrical connections
- Requires no specialized tooling
- Reduced down time means less maintenance cost and more production time

Magnetically Driven Sealless Design

- Eliminates costly seal flush systems required for double mechanical seals
- Patent pending spline design allows the magnet to “float” on shaft
- Fully Encapsulated Magnets are self aligning and offer maximum corrosion resistance
- No axial loads induced on the drive shaft
- Modular Magnet Hub: One drive magnet per pump size, with interchangeable adapter. Hubs fit both standard NEMA and IEC motors

Control Options

The MPC Vector is a microprocessor based controller designed for convenient, accurate, and efficient motor speed management. It controls the motor speed utilizing a state of the art sensorless vector drive. The ergonomic, handheld interface provides the freedom of mounting the keypad up to 1000 ft away for ease of access. Add an MPC Vector to your Eclipse pump or system and take advantage of the complete system integration between pump and process.

MPC VECTOR

- Sensorless, vector type drive
- Wide range of flow control
- Infinite turndown with the appropriate motor
- Displays flow in GPH, LPH, GPM, or LPM
- Displays speed in RPM
- Display can be set in one of five programmable languages
- NEMA 4X (IP56) rating on the control and handheld keypad enclosures
- Can be mounted up to 1000 ft (304 m)
- Security code to lock out unauthorized users
- Input, output processor (4-20 mA and digital)
- PID loop for closed loop flow control



Use the MPC Vector to Monitor:

- Supply tank level
- Verify pump flow
- Indicate remote status
- Indicate pump alarm status
- Indicate auto/manual status





Pulsafeeder's Engineered Solutions

From design to install, skid systems provide the easiest “out of the box” solution for applications large and small. Pulsafeeder application engineers assist you in designing the perfect system to meet your pumping requirements. Your engineers spend less time designing a chemical feed system and you save money. They can be purchased and installed for up to 20% less than traditional stick build systems and can include complete controls integration.

Skids arrive on site completely wired, plumbed, tested and ready for installation and operation. Installation is simple with only four field connections to hook up to existing piping. Detailed installation instructions are included. Our application engineers are just a phone call away to assist you with any install questions you may have.

From concept to construction, Pulsafeeder's Engineered Solutions arrive ready for service.

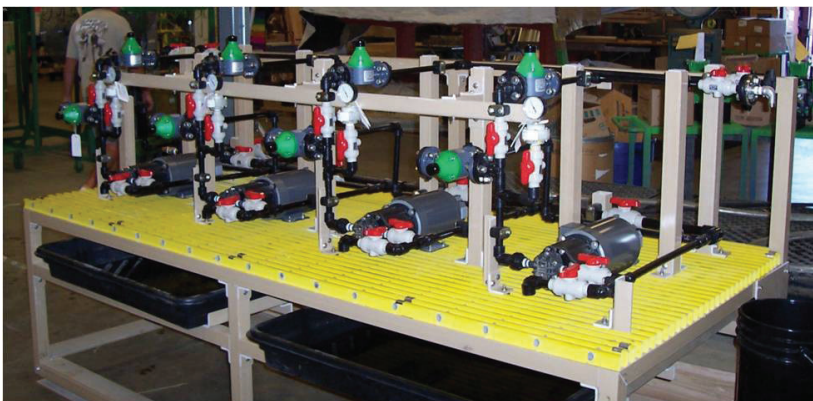
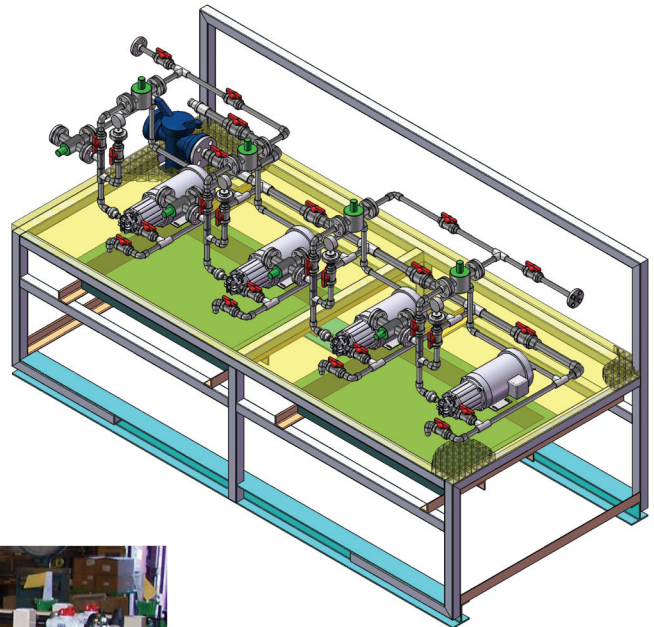

Parts & Accessories



A **KOPkit[®] (Keep On Pumping)** can help you cut downtime and put you back in business fast. Use KOPkits for preventive maintenance and to ensure continuous high performance from your Pulsafeeder metering pump.



MPC Vector

A state of the art multi-functional controller that utilizes a state of the art sensorless vector motor control technology.

Pressure Relief Valves

prevent an overpressurization situation from ever damaging your pumps or pipes. Overpressurization can occur when a valve is closed or a blockage occurs. They are always recommended equipment for any pump or skid system.



Calibration Columns

These columns are constructed of clear PVC tubes with PVC end caps or an option for Borosilicate glass with Teflon end caps and should be sized for a 30-second draw down.



Y-Strainers arrest out debris in pipelines, protecting equipment and processes. They prevent premature wear of the rotating components within a pump.



Pressure Gauges are relied on to measure pressure in the system. Proper pressure is necessary to ensure flow. Pulsafeeder Pressure Gauges are accurate and reliable.



Back Pressure Valves provide positive back pressure for systems with less than the minimum required pressure difference between the discharge and suction side of the metering pump. They assure optimum metering performance.

pulsafeeder.com