

# NOVADOS

## Metering Pumps



**Product News :**  
Double-acting diaphragm pump head

# > A Selection of Metering Pumps Beyond Compare

With NOVADOS metering pumps, Bran+Luebbe offers an unrivalled range for virtually all applications where liquids have to be metered or blended.

The product range comprises leak-free diaphragm pumps as well as plunger pumps.

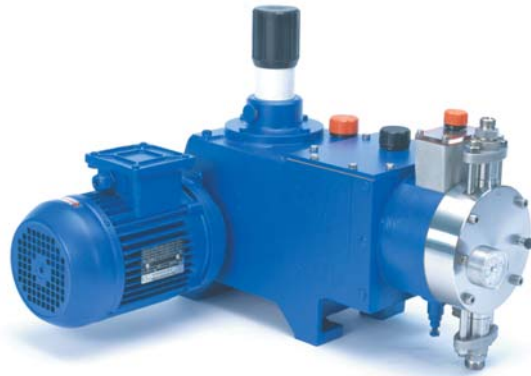

*Metering pump type H2 with diaphragm pump head and manual stroke length adjustment*

## > Applications

### Industries

- Chemical Processing
- Food & Beverages
- Detergents
- Energy
- Environmental
- Oil & Gas
- Personal Care
- Petrochemical
- Pharmaceutical & Biotechnology
- Pulp & Paper
- Textile
- Water Treatment

### Liquids

- From harmless to aggressive, toxic or hazardous
- From clean to slurries with up to 20% solids content
- From low to high viscosity up to 5000 cP and beyond

### Operating Options

- Standard metering of one component
- Process metering of one component utilizing a multihead pump
- Multi stream metering of several individual components to separate injection points or for blending

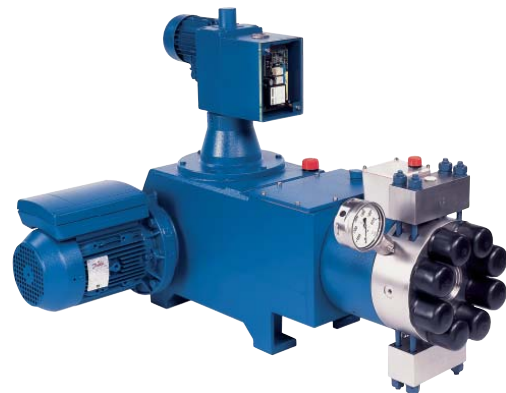

*Metering pump type H4 with high pressure diaphragm pump head and electric stroke length adjustment*

## > Common design features

- Modular metering pump gears with built-in low noise worm reductions
- Individual stroke length setting utilizing the unique z-shaped crankshaft
- Range of pumphead sizes to allow a flow range of between smallest 0.1 l/h up to largest 40000 l/h on a single head
- Manual or auto flow rate control options



*Metering pump type 3H3-2H2 with electric stroke length adjustment and manual emergency override*

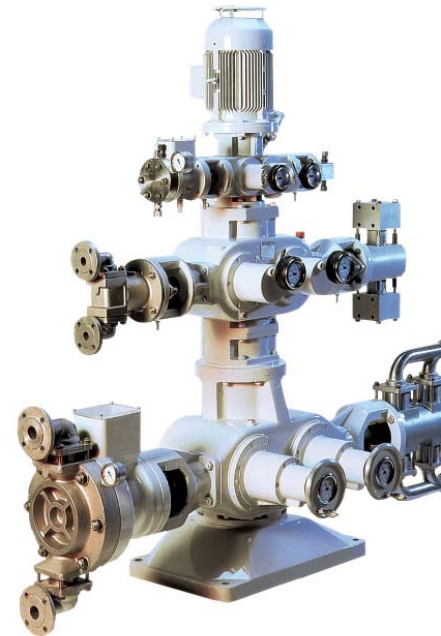

*Metering pump type CS-C-J with a variety of different pump heads and individual manual stroke length adjustment*

## > Advantages

### Flexible

- Optimal capacity adaptation to widely varying production processes
- Variable stroke length for each pump allows independent flow rate adjustment of each pump component
- Variable speed drive allows flow rate variations while maintaining constant proportions

### Economical

- Automation allows higher production efficiency to be achieved

### Adaptable

- Existing installations can be altered or expanded with extra pumps or automatic control

# ➤ Concept of the Bran+Luebbe Metering Pumps

## ➤ Working principle of the metering pump

Metering pumps normally comprise of a motor, gearbox and pumphead.

The gear reduces the motor speed and converts the rotary motion into a reciprocating movement of a plunger in the pump head.

The plunger movement generates a stream of liquid utilizing a suction and discharge valve that are opened and closed alternately. Suction and discharge valves are self-acting.

Flow rate of a metering pump is basically defined by the plunger diameter, stroke length and stroking speed.

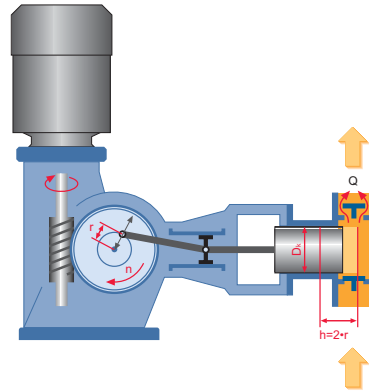

Metering pump type H1 with plastic diaphragm pump head and pneumatic flow rate control

## ➤ Options for stroke length adjustment

### Manual

- with integrated scale with 0.02 mm resolution

### Electric

- direct remote control
- with controller input signal 0/4...20 mA

### Pneumatic

- direct remote control
- with signal converter (input signal 0.2... 1 bar)
- with signal converter (input signal 0/4... 20 mA)

## ➤ Simply effective: Flow rate adjustment by the z-shaped crankshaft

Flow rate can be adjusted linearly and continuously between zero and maximum by altering the position of the z-shaped crankshaft. This design allows adjustment while the pump is operating or at standstill.

Bran+Luebbe NOVADOS metering pumps exceed the requirements of API 675 in terms of metering accuracy, linearity and reproducibility.

For a more detailed description please ask for a free copy of our CD-ROM "The Function of the Bran+Luebbe Stroke Length Adjustment via z-shaped crank shaft". Or visit our website [www.branluebbe.com](http://www.branluebbe.com)

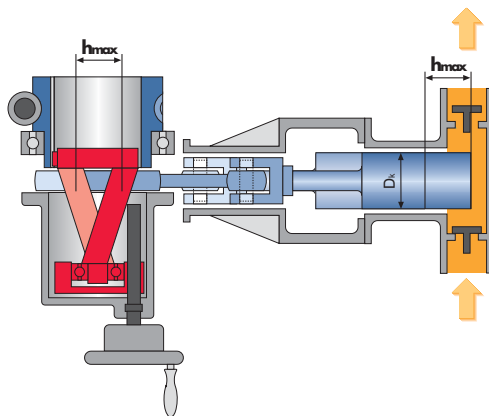

## ➤ Plunger metering pumps

### The right choice for metering harmless or non-critical fluids

Even though the design of plunger pumpheads is quite simple, these Bran+Luebbe pumps demonstrate outstanding performance. This is due to the Bran+Luebbe metering pump valves in combination with the high-precision metering gear.

For certain applications it is possible to use double-acting pumpheads to deliver twice the flow on a single head.

Flow rates range from 100 ml/h up to 40000 l/h, operating pressure may be as high as 1000 bar.

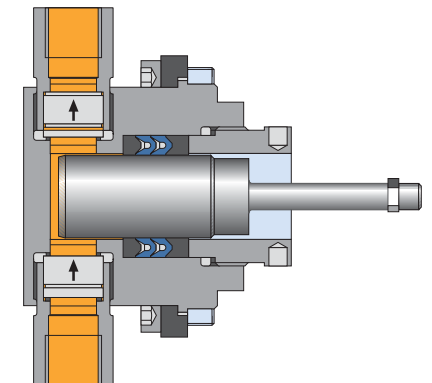

## ➤ Diaphragm metering pumps

### Diaphragm position control for maximum operating security

A leak-proof pump is the right choice whenever product purity or sterility are imperative or when toxic liquids must be handled.

Bran+Luebbe offers a wide range of hydraulically actuated double diaphragm pumps that offer flow rates ranging from 100 ml/hr up to 10000 l/hr at operating pressures up to 1000 bar. The Bran+Luebbe Positive Diaphragm Position Control system (PDPC) ensures that the diaphragm cannot be damaged under critical conditions such as a blocked pipe or closed valves upstream or downstream of the pump.

This system allows unobstructed movement of the diaphragm in the pumping chamber making the pump suitable for the metering of slurries.

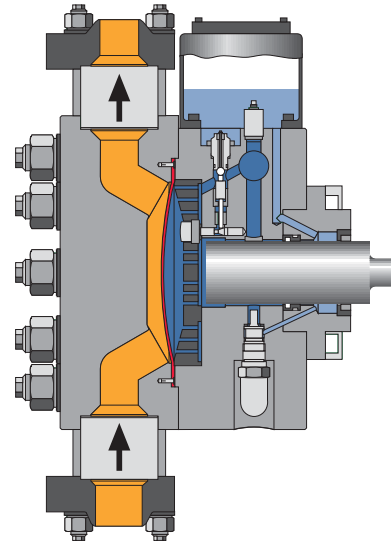

For a more detailed description please ask for a free copy of our CD-ROM "The Function of the Diaphragm Metering Pump head and the Diaphragm Position Control". Or visit our website: [www.branluebbe.com](http://www.branluebbe.com)

## ➤ NOVADOS diaphragm pumps: Features

- Up to 400 bar operating pressure (PTFE diaphragm)
- Up to 1000 bar operating pressure (metallic diaphragm)
- Up to 150°C operating temperature (engineered versions up to 400°C)
- Meet and exceed API 675 requirements
- Safe dry-run capabilities
- High volumetric efficiency
- Best metering accuracy
- Hermetically sealed by two (2) diaphragm layers with diaphragm condition monitoring as a standard
- Off the shelf NOVALINK CSM 2 Diagnosis interface
- Customizing to specific customer requirements is possible

## ➤ Double-acting diaphragm pumps

**In challenging operating conditions, greater flow rate, high reliability, smaller footprint and with cost savings!!**



As an alternative to large single head pumps or smaller multi-headed pumps, Bran+Luebbe can now offer the benefits of a double-acting diaphragm pump head that enables twice the flow rate on a single gearbox whilst maintaining the same metering accuracy.

### ➤ Advantages

- Doubled flow rate
- Less footprint required compared with conventional duplex pumps
- When executed with the pre-pressure module best suited for energy optimized recirculation applications

**Product News :**  
Double-acting diaphragm pump head

# NOVADOS-Solutions

Options to suit special applications

## Pump head executions

- heating or cooling jackets even incl. valves
- quick-change valves
- remote valves
- optimized flow channels for slurries or viscous fluids

## Valve designs

- Ball valves (single, double or triple)
- Cone valves with or without spring
- Plate valves

*Process metering pump type 3BS with diaphragm pump head and electric stroke length adjustment*

## Materials of construction for liquid-wetted parts of the pump

- Housings of Stainless steel 1.4571, 1.4581, 1.4462
- Alternatively PVC, PP, PVDF or stainless steel lined with HALAR® (E-CTFE)
- Diaphragms of PTFE or stainless steel 1.4310
- Plungers of stainless steel, ceramic, tungsten carbide
- Valves of stainless steel, plastic, hard metals or exotic material
- Upon request practically all exotic materials such as Hastelloy, Titanium, Stellite etc. are available as well

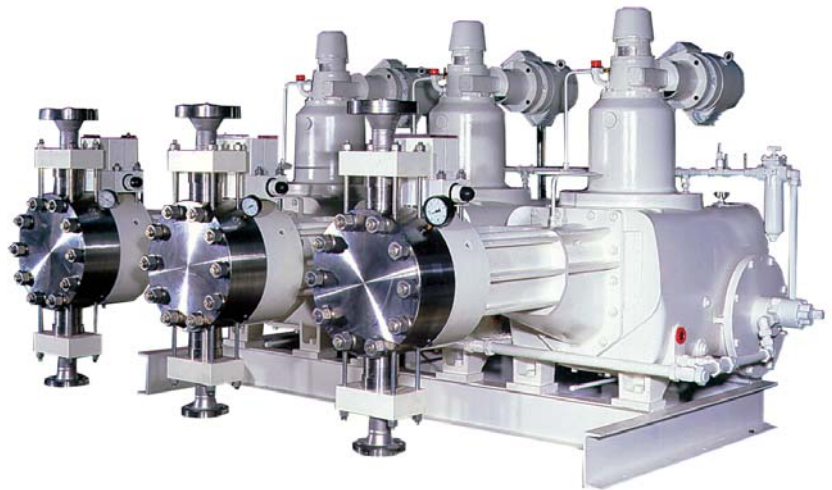

Horizontal and vertical combinations

Bran+Luebbe is the only pump manufacturer worldwide to offer both vertical and horizontal combinations of metering pumps. Possible equipment combinations range from simplex pumps for one stream of liquid to multiplex pumps with up to 12 different streams, each of them can be controlled independently.

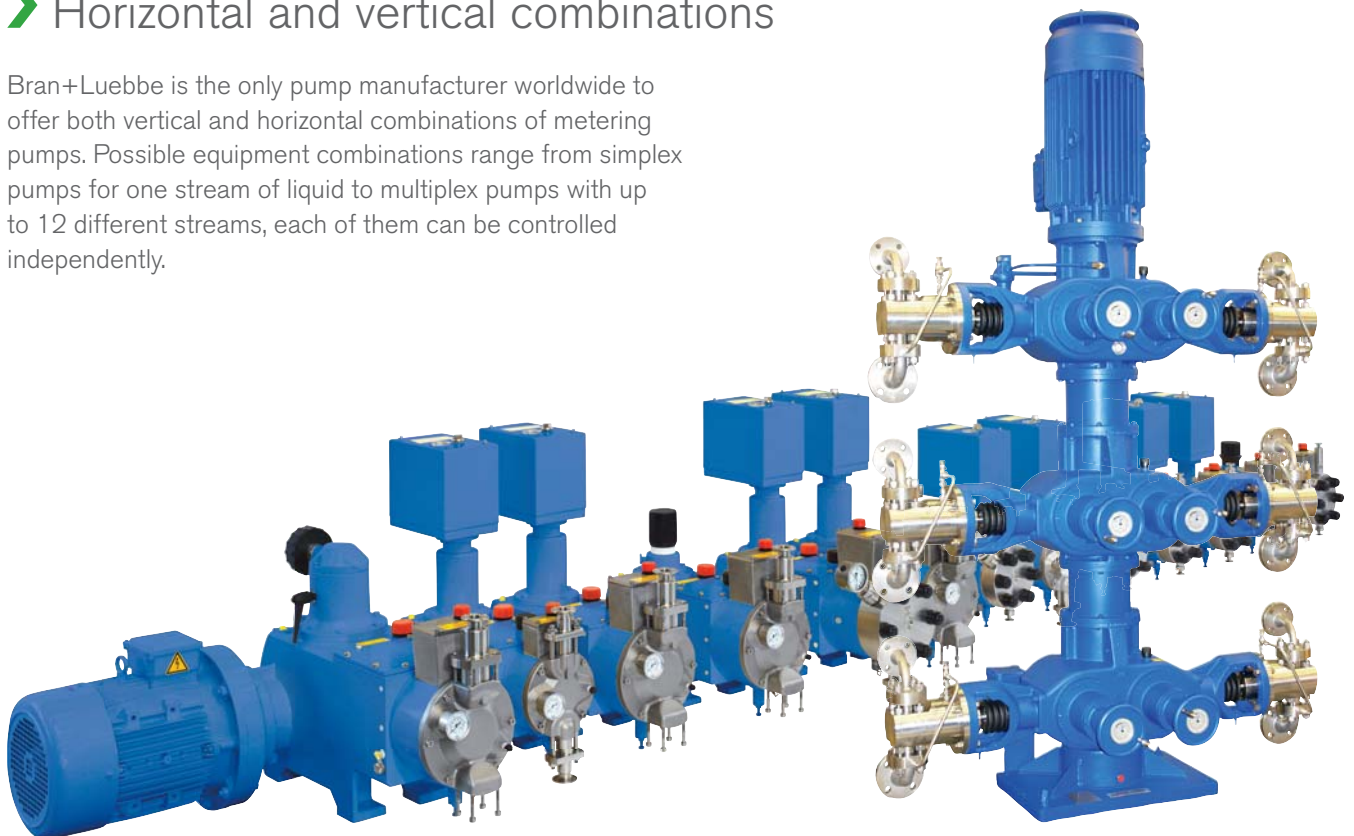

# > The product range

> More examples of Bran+Luebbe products with high quality standard, innovation and know-how.

## Metering pumps

for universal application  
in the low to medium  
requirement range

*ProCam*

*ProCam Smart*

*ProCam Sainitary & Hygienic*



## Process systems

as a complete  
solution for increased  
productivity and  
quality

*AutoBlend*

*Metering and mixing systems*



## Process pumps

for large flow rates and  
high operating pressures

*NOVAPLEX*

*NOVAPLEX Integral*

*MEGANIZER*

*High pressure homogenizer*



## Oil & Gas systems

to aid oil & gas recovery  
onshore and offshore

*Solar Panel Packages*

*Chemical Injection Systems*

*Flow Control Device Panels*



## Dynamic in-line mixer

for gentle but intensive mixing

*PENTAX*

*PENTAX Hygienic*



## On-line analyzers

for use in water and  
effluent treatment

*PowerMon*

*PowerMon S*



# SPX®

Your local contact:



SPX Flow Technology - Werkstrasse 4 - D-22803 Norderstedt

Phone: +49 52202-0 - Fax: +49 52202-444

E-mail: [bl@spx.com](mailto:bl@spx.com) - <http://www.branluebbe.com>

For more information about our worldwide locations, approvals, certifications, and local representatives, please visit [www.branluebbe.com](http://www.branluebbe.com) / [www.spxft.com](http://www.spxft.com)

SPX Corporation reserves the right to incorporate our latest design and material changes without notice or obligation.

Design features, materials of construction and dimensional data, as described in this bulletin, are provided for your information only and should not be relied upon unless confirmed in writing.

Issued: BL-102 - E - 1.0 - 04/2010

Copyright © SPX Corporation 2010