

Series GJR

MAGNETIC DRIVE GEAR PUMP



Series GJR pumps deliver exceptional pumping performance and long life in abrasive fluid applications. Abrasive fluids, such as pigmented paints and inks, often cause significant pump wear, dramatically shortening pump life. Micropump's Series GJR pumps use advanced materials and design processes to extend pump life.

The Series GJR pumps deliver the same exceptional pumping features that you've come to expect from Series GJ pumps. These compact magnetically driven gear pumps feature a cavity style design for smooth pulseless fluid delivery. The magnetic drive removes the need for direct drive connection to the pump gears, eliminating leak points associated with shaft seals, while providing energy-efficient fluid delivery. Series GJR pumps are ideal for a wide range of abrasive fluid applications.

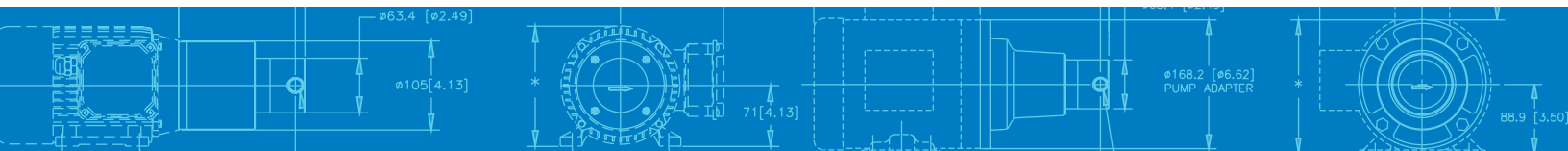

CHEMICAL AND ABRASIVE RESISTANCE

Series GJR has a long-life in aggressive chemical and abrasive fluid environments.

NO LEAK-PRONE DYNAMIC SEALS

The magnetic drive static PTFE seals keep the fluid securely inside the pump and potential contaminants out.

SMOOTH PULSELESS DELIVERY

Positive displacement, precision gears provide consistent fluid delivery in continuous processes.

SMALL SIZE / HIGH-PERFORMANCE

The miniature size of the Series GJR coupled with the compact EagleDrive creates a high performance package that is easy incorporated into your system design.

CAVITY STYLE PUMPS

Cavity Style pumps are excellent for wide-ranging inlet and outlet operating conditions, and allow for intermittently pumping in reverse.

ELECTROMAGNETIC DRIVE

The unique design of the electromagnetic drive eliminates all moving parts to increase motor life. Variable speed operation is controlled via 0-5 VDC, 4-20mA current loop, or manual control.

ENHANCED EFFICIENCY

As part of the IDEX Corporation, Micropump can offer fully-integrated liquid subassemblies, gas management systems, and precision components. Products include Pumps, Valves, Manifolds, Tubing, Fittings, Degassing/Debubbling Systems, Air Compressors, Vacuum Generators, and HPLC Columns. Additional services are custom fluidic engineering and development, contract manufacturing, extrusion, molding, machining, and diffusion bonding.

PUMP PERFORMANCE

GJR-N21

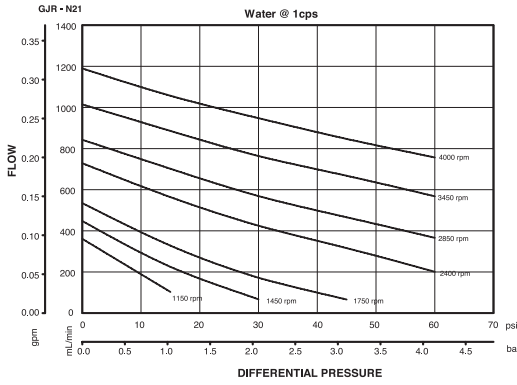

GJR-N23

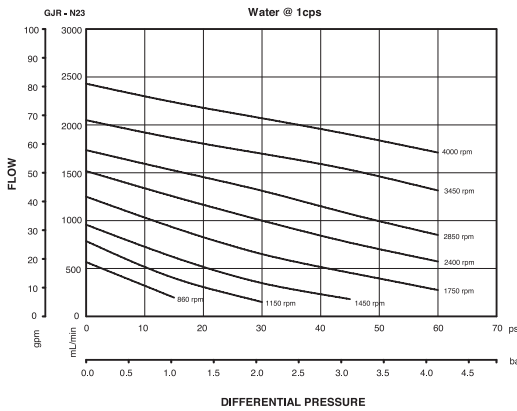

DIMENSIONS

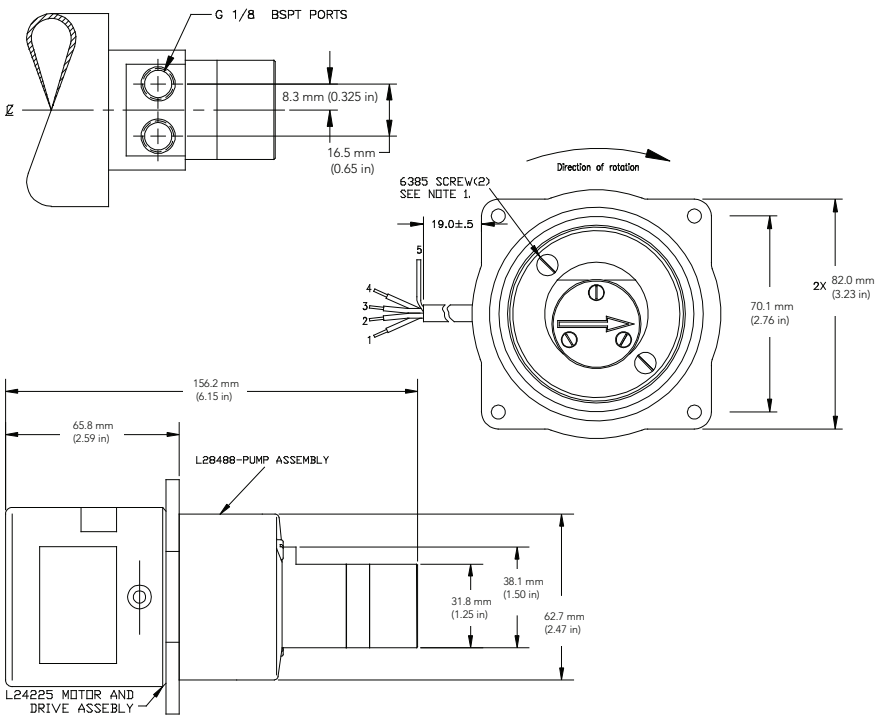

PERFORMANCE SUMMARY

FLOW RATE AT 4000 RPM

- ▶ 2400 mL/min (0.63 gpm)

DISPLACEMENT

- ▶ Gear Set N21 N23
- ▶ mL/rev 0.29 0.61

MAXIMUM RATED DIFFERENTIAL PRESSURE

- ▶ 4.0 Bar (58 psi)

MAXIMUM RATED SYSTEM PRESSURE

- ▶ 21 Bar (300 psi)

TEMPERATURE RANGE

- ▶ -46 to 121 °C (-50 to 250 °F)

VISCOSITY RANGE

- ▶ 0.5 to 1500 cps

MAXIMUM SPEED

- ▶ 5000 rpm

PUMP CONSTRUCTION

- ▶ Magnetic drive gear pump
- ▶ Cavity style
- ▶ Spur gears
- ▶ PTFE seals

MAGNETS

DRIVEN AND DRIVING

- ▶ Ferrite
- ▶ Rare earth

MICROPUMP



Micropump, Inc | A Unit of IDEX Corp. | 1402 NE 136th Avenue • Vancouver, WA 98684

T 800.671.6269 • +1.360.253.2008 | F +1.360.253.8294 | info.micropump@idexcorp.com | www.micropump.com

ACTUAL PERFORMANCE MAY VARY. Specifications are subject to change without notice. ©2013 Micropump, Inc., A Unit of IDEX Corporation. Micropump and the Micropump logo are registered trademarks of Micropump, Inc.

REV. 09/13/13