

ProCam

DIAPHRAGM AND PLUNGER METERING PUMPS

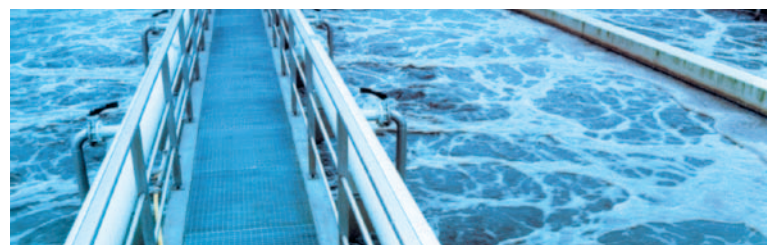

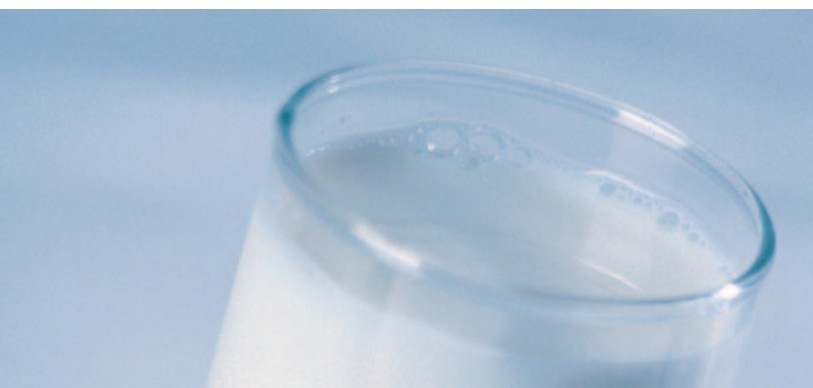

SPXFLOW

SPX FLOW, Inc. (NYSE:FLOW) is a leading manufacturer of innovative flow technologies, many of which help define the industry standard in the market segments they serve. From its headquarters in Charlotte, North Carolina, it operates a sales and support network, centers of manufacturing excellence, and advanced engineering facilities, throughout the world. Its cutting-edge flow components and process equipment portfolio includes a wide range of pumps, valves, heat exchangers, mixers, homogenizers, separators, filters, UHT, and drying technology that meet many application needs. Its expert engineering capability also makes it a premium supplier of customized solutions and complete, turn-key packages to meet the most exacting of installation demands.

Incorporating many leading brands, SPX FLOW has a long history of serving the food and beverage, power and energy, and industrial market sectors. Its designs and engineered solutions help customers drive efficiency and productivity, increase quality and reliability, and meet the latest regulatory demands. In-depth understanding of applications and processes, state-of-the-art Innovation Centers, and advanced pilot/testing technology further assist in optimizing processes and reducing timescales to reliably meet production targets.

To learn more about SPX FLOW capabilities, its latest technology innovations and complete service offerings, please visit www.spxflow.com.

FOR MORE THAN 80 YEARS, SPX FLOW'S BRAN+LUEBBE BRAND HAS BEEN PROVIDING CUSTOMERS WITH HIGH QUALITY METERING, PROCESSING AND ANALYSING EQUIPMENT.

As part of the global SPX FLOW, Inc. , we are one of the world's most reputable manufacturers of metering and process pumps, process systems as well as analyzing technologies. Our engineers have comprehensive process and applications knowledge across a wide range of markets. This has resulted in product innovations and developments which harness the latest technology whilst meeting the highest quality standards.

> Bran+Luebbe®

ProCam Metering Pumps

ProCam is an economical range of metering pumps, designed for use in many industrial or hygienic processes. The mechanically actuated diaphragm pumps offer safe and reliable operation for hazardous liquids with a plunger pump head option for high pressure, low flow duties. The pumps are suitable for single & multi-stream processes and auto-control using variable speed, electric stroke or a combination of both.

SAMPLES OF EXECUTED PUMPS



Designed for operating pressures up to 20 bar
and flow rates up to 3,000 l/h



Plunger metering pump with stainless steel
pump head and manual flow rate control.

THE IDEAL MODEL FOR A WIDE RANGE OF APPLICATIONS



Multi-headed ProCam metering pump



Diaphragm metering pump
designed for hygienic applications



ProCam Compact Metering Station

PROCAM PLUNGER METERING PUMPS	PAGE	6 - 7
PROCAM DIAPHRAGM METERING PUMPS	PAGE	8 - 9
PROCAM HYGIENIC	PAGE	10 - 11
PROCAM COMPACT METERING STATION	PAGE	12 - 13

ProCam Plunger Metering Pumps



Plunger metering pump with stainless steel pump head and manual flow rate control.

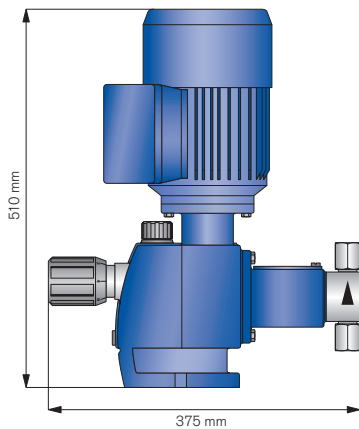

Type PS 3 up to PS 25
(dimensions are max. dimensions)

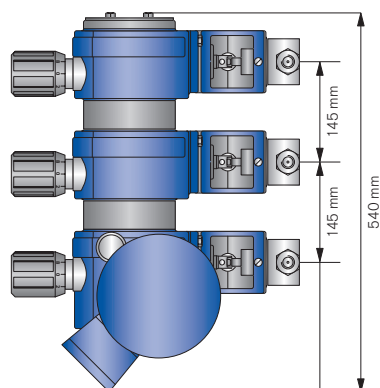

Type PS 3 up to PS 25
(dimensions are max. dimensions)

Economical and reliable, the robust and compact design of the ProCam plunger pump allows high operational security.

AT A GLANCE

- Economic metering of non-hazardous fluids
- Operating pressure up to 80 bar
- Flow rates from 0.16 to approx. 60 l/h
- Robust gear technology with proven lost motion design for continuous operation at max. flow / pressure conditions
- Linear stroke adjustment with manual or electric options
- High operational security



GENERAL

- Gear box in a rugged cast iron housing
- Integrated worm gear
- Splash lubrication
- Electric motor (IEC, IP55)

STANDARD

- Single pump with plunger pump head
- Manual stroke adjustment
- Electric motor with fixed speed
- Materials for pump head and valve housing
 - Stainless steel

OPTIONS

- Multiple pumps with up to 6 plunger pump heads are available
- Can be combined with ProCam diaphragm metering pump
- Electric stroke length adjustment (also with integrated controller)
- Electric motor with variable speed
- Hazardous area design (up to Zone 1, IIC, T4)

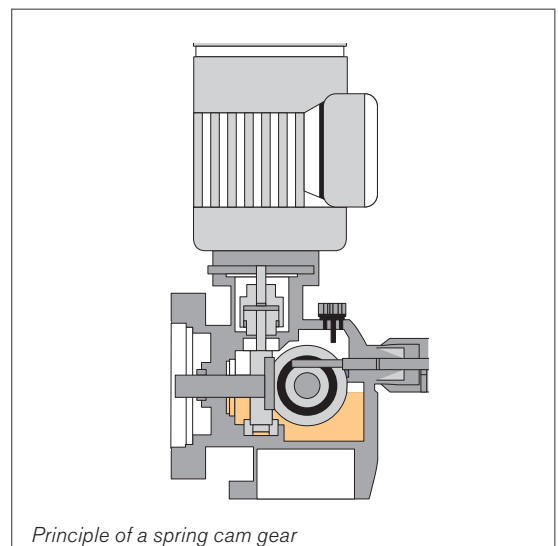
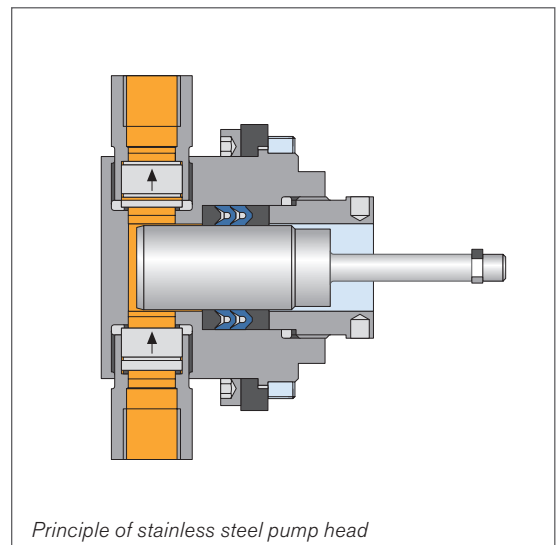

FLOW RATE AND PRESSURES

TYPE	MAX. FLOW RATE (L/H)				MAX. PRESSURE (BAR)	MATERIAL IN CONTACT WITH METERED LIQUID
	STROKE FREQUENCY (1/MIN)					
	50	72	100	144		
PS 3	0.16	0.23	0.32	0.46	80	1.4571
PS 5	0.45	0.64	0.90	1.29	80	1.4571
PS 8	1.15	1.65	2.30	3.30	80	1,4571
PS 10	3.40	4.80	6.70	9.70	80	1.4571/1.4581
PS 16	8.60	12.40	17.20	24.80	80	1.4571/1.4581
PS 25	21.00	30.20	42.00	60.40	32	1.4571/1.4581

ProCam Diaphragm Metering Pumps

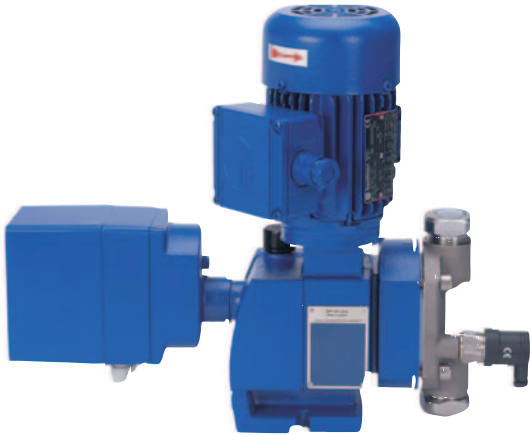

Designed for operating pressures up to 20 bar and flow rates up to 3,000 l/h

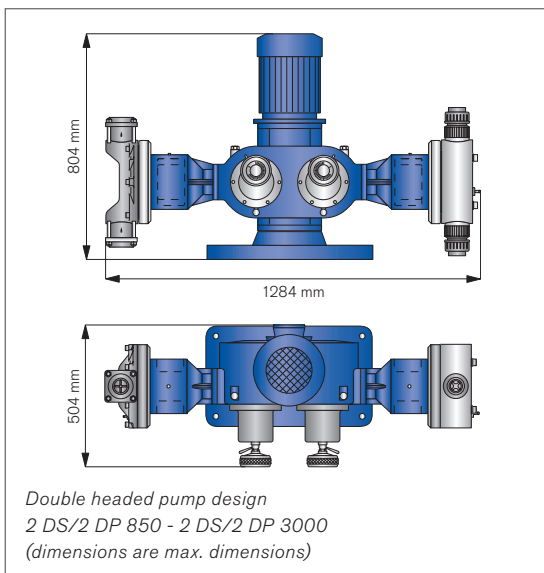
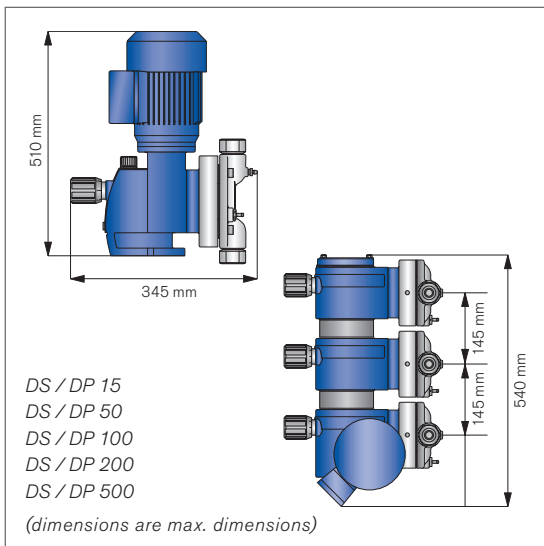

Our classic series of mechanically actuated double diaphragm pumps for low to medium range applications, brings the advantages and security of the double diaphragm concept to a wide variety of applications at an economical price.

AT A GLANCE

- Hermetically sealed pump head with mechanically operated PTFE double diaphragm allowing
 - safe metering of hazardous liquids
 - contamination free operation (important in potable water production)
- Allows economic operation without loss in operating safety and reliability
- 2 years warranty of PTFE double diaphragm
- Diaphragm condition monitoring
- Outstanding corrosion resistance due to high quality PTFE double diaphragm



GENERAL

- Gear box in a rugged cast iron housing
- Integrated worm gear
- Splash lubrication
- Electric motor (IEC, IP55)

STANDARD

- Diaphragm pump with a single pump head
- Manual stroke adjustment
- Drive with fixed speed
- Materials for pump head and valve housing
 - Stainless steel
 - PVC

OPTIONS

- Multiple pumps with up to 6 pump heads are available (valid for type DS/DP15 – DS/DP500) or 2 pump heads (valid for type DS/DP850 and DS/DP3000)
- Electric stroke length adjustment (also with integrated controller)
- Electric motor with variable speed
- Hazardous area design (up to Zone 1, IIC, T4)

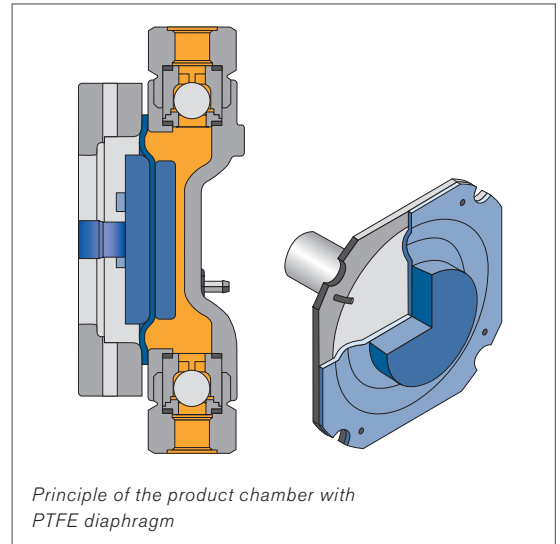

Principle of the product chamber with PTFE diaphragm

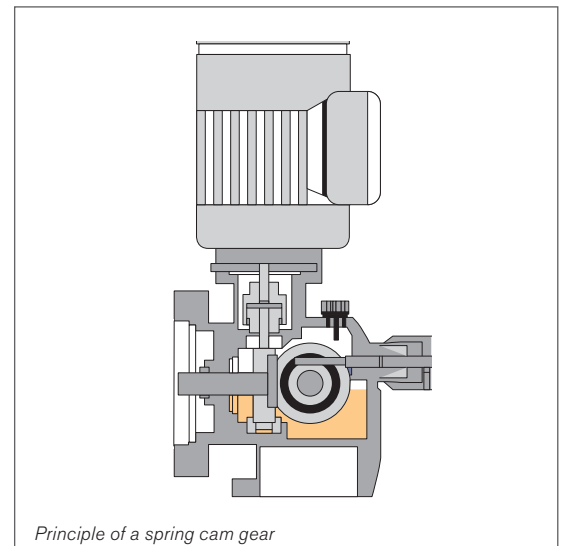

Principle of a spring cam gear

FLOW RATE AND PRESSURE

TYPE	MAX. FLOW RATE (L/H)					MAX. PRESSURE (BAR)
	STROKE FREQUENCY (1/MIN)					
	50	72	100	144	200	
DS/DP 15	5	7,5	10	15		20
DS/DP 50	17,5	25	35	50		10
DS/DP 100	35	50	70	100		4
DS/DP 200	70	100	140	200		12
DS/DP 500	175	250	350	500		5
DS/DP 850	300	430	600	860	1200	3
DS/DP 3000	1040	1500	2080	3000		5

* Operating pressure for plastic pump heads: 10 bar. With multiple pumps (4 - 6 heads) the max. operating pressure is only 50% of the indicated pressure.

ProCam Hygienic



Clamp-connection and ball valve in SS316L with Ra 0.8, PTFE gaskets (FDA approved)

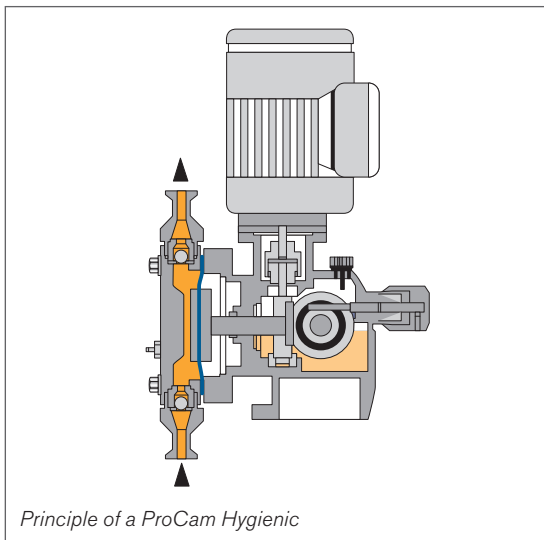

AT A GLANCE

- CIP (cleaning-in-place) at 83°C
- Covers requirements in hygienic and sterile applications
- Specifically designed for applications in the pharmaceutical industry, biotechnology, cosmetics, personal care, food and beverage industry
- Flexible multi-pump head design



FACTS

- Metering pump with PTFE double diaphragm (FDA approved) and diaphragm condition monitoring by pressure switch
- Hygienic valve design
- Little residence time in the product chamber of the pump head
- Double diaphragm and valve gaskets are made of PTFE (FDA)
- Coating according to FDA requirements
- Front cover, valves, connections in material SS 316 L with surface roughness RA 0.8 (optional Ra 0.4)



FLOW RATE AND PRESSURES

TYPE	MAX. FLOW RATE (L/H)				MAX. PRESSURE (BAR)	CONNECTIONS
	HUBFREQUENZ (1/MIN)					
	50	72	100	144		
DS 15	5	7,5	10	15	20	½" Clamp
DS 50	17,5	25	35	50	10	½" Clamp
DS 100	35	50	70	100	4	½" Clamp
DS 200	70	100	140	200	12	½" Clamp
DS 500	175	250	350	500	5	1" Clamp

* With multiple pumps (4 – 6 heads) the max. operating pressure is only 50% of the indicated pressure.

ProCam Compact Metering Station



Compact design – based on the ProCam metering pump this is a convenient solution for chemical preparation and metering.

SOLID DESIGN

- Stable base plate for pumps up to 50 kg
- Fluid temperature up to 50°C
- Tank UV stabilised for outdoor use
- Polyethylene tank material corrosion resistant against many chemicals
- Brackets for floor mounting available

COMPLETE SOLUTION AND OPTIONS

- Tank sizes from 60 to 500 litres (or on request)
- Standard equipment includes metering pump, tank, suction pipe, inlet valve, manual stirrer and stable mounting plate for pumps
- Easy to read liquid level due to scale moulded into the tank wall
- Wide filling port with manual screw lid for easy handling

Options:

- Motor driven stirrer
- Level switches (1 or 2 contacts)
- Pressure relief valve with return to the tank
- Tank drain

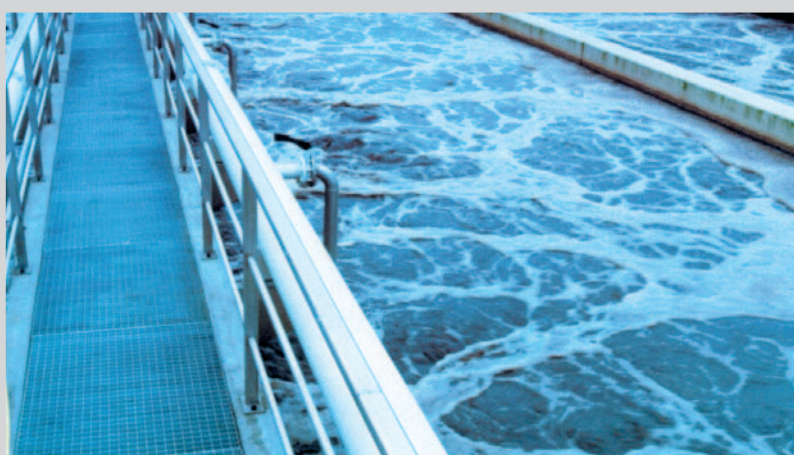

SCOPE OF SUPPLY

- 1 ProCam metering pump
- 2 Tank (PE)
- 3 Base plate (PVC)
- 4 Suction pipe (PVC)
- 5 Foot valve (PVC)
- 6 Manual stirrer (PVC)
- 7 Option: Motor driven stirrer
- 8 Option: Level switches
- 9 Option: Pressure relief valve
- 10 Option: Drain
- 11 Option: 4 brackets (PE) for floor mounting

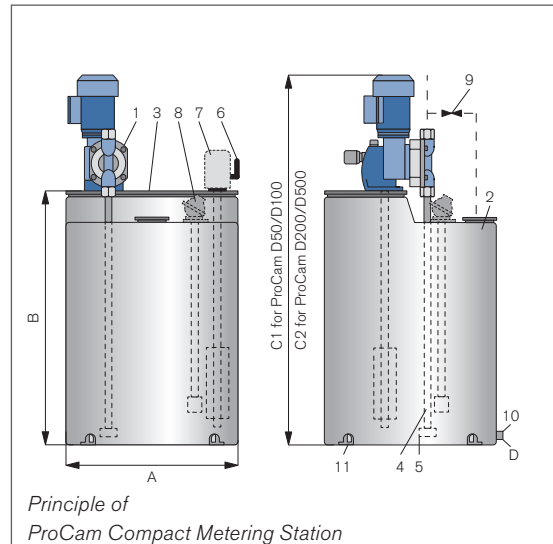

AT A GLANCE

- Chemical industry e.g. metering of additives or inhibitors
- Water treatment plants
- CIP systems in the food & beverage industry
- Applications in the galvanizing industry
- Preparation of fertilizer solutions

VOLUME AND DIMENSIONS

TANK	Ø A	B	C1	C2	D
60 l	450	545	925	965	1/2"
100 l	470	730	110	1150	1/2"
200 l	610	875	1255	1295	1/2"
300 l	680	950	1330	1370	1"
500 l	830	1065	1445	1485	1"

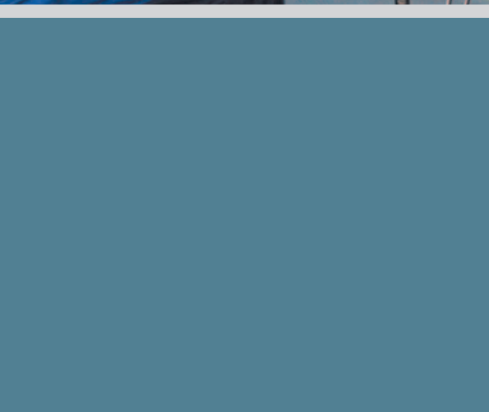

Our service at a glance



Start up

Regardless of location – on request our SPX FLOW technician will assist with the installation and the professional commissioning of your plant on site and ensure optimum adaptation of our pumps and systems to your production and processing environment. We ensure the full operational capability of our pumps and systems from the start.



Repair

To carry out repairs, please contact our experienced service team which of course exclusively uses original spare parts of manufacturer quality.



Maintenance / Maintenance Contracts

The regular performance of maintenance work by qualified SPX Flow technicians gives you the assurance of maximum availability of your systems. For this reason we offer you the possibility to enter into a maintenance contract tailored to your needs. We support our products for the entire lifetime of the pump, and we accept all major inspection and maintenance tasks - possible sources of errors are detected and remedied at an early stage, so that production stops are largely avoided. Your advantage: As a maintenance customer you will enjoy priority in all service issues and receive a discount on spare parts.



Upgrades

We offer to customize your pump through a conversion in response to changes in production and process requirements. By using improved designs and new materials, we can optimize the pump performance and increase reliability. This will give you a reasonable alternative to a purchase of a new pump.





Diagnostic - Online / Offline / Remote

With our NOVALINK-CSM 2 system (Continuous status monitoring), we provide you with permanent or temporary fault analyses so that you avoid unplanned stop time through early detection of faults.Fehlern.

Advantages:

- Improved pump availability
- Planning of maintenance
- Optimization of production processes



Customer Support / Hotline

Advice and support are important to us. As a customer you are our number one priority. We advise you in error messages and assist you in the selection of spare parts. In determining the maintenance intervals you can count on our help.



Spare Parts

By using exclusively original spare parts in consistent high quality, we offer you the security of the proper functioning of your pump. A high availability of original spare parts in stock is a matter of course for us and gives us the opportunity to supply many spare parts within 24 hours.



Training

Our training courses are practical and tailored to your needs and provide detailed knowledge about function, design and repair of our pumps and systems. Our training courses are intended for users, technicians or engineers.

THE PRODUCT RANGE - MORE EXAMPLES OF BRAN+LUEBBE PRODUCTS WITH HIGH QUALITY STANDARD, INNOVATION AND KNOW-HOW.



Metering pumps
for all process areas
where liquids are
metered and mixed.
NOVADOS



Process pumps
for large flow rates and
high operating pressures
NOVAPLEX *Classic*
NOVAPLEX *Integral*
NOVAPLEX *Vector*



**Dynamic
in-line mixer**
for gentle
but intensive mixing
PENTAX
PENTAX Hygienic



Process systems
as a complete
solution for increased
productivity and quality
AutoBlend
Metering and mixing systems



Oil & Gas systems
to aid oil & gas recovery
onshore and offshore
Solar Panel Packages
Chemical Injection Systems
Flow Control Device Panels



On-line Analyzers
for use in water and
effluent treatment
PowerMon
PowerMon S
PowerMon Compact

Global Locations

EMEA

SPX FLOW TECHNOLOGY

Werkstraße 4
D-22844 Norderstedt
Germany
Phone: +49 (0) 40 - 522 02 -0
E-Mail: branluebbe@spxflow.com

EMEA

SPX FLOW TECHNOLOGY

Ironstone Way
Brixworth, Northants, NN6 9UD
United Kingdom
Phone: +44 (0) 1604 880751
E-Mail: ft.brixworth.sales@spxflow.com

EMEA

SPX FLOW TECHNOLOGY

P.O. Box 299745,
Downtown Jebel Ali
The Galleries 4
Dubai, U.A.E.
Phone: +971 481 43400
E-Mail: FT.Dubai.sales@spxflow.com

AMERICAS

SPX FLOW, INC.

4151 North Service Road
Burlington
ON, L7L 4X6, Canada
Phone: +1 (905) 315 3800
E-Mail: cu.burlington@spxflow.com

AMERICAS

SPX FLOW TECHNOLOGY

Rua João Daprat, 231
São Bernardo do Campo
SP 09600-010 - Brazil
Phone: +55 11 2127 8278

AMERICAS

**SPX FLOW TECHNOLOGY
(F&B GROUP)**

611 Sugar Creek Road
Delavan, WI 53115 USA
Phone: +1 (800) 252-5200 or
+1 (262) 728-1900
E-Mail: branluebbe.americas@spxflow.com

APAC

SPX FLOW TECHNOLOGY

20 Pioneer Crescent #06-01
West Park BizCentral
Singapore 628555
Phone: +65 6568 1568
E-Mail: asia.pacific@spxflow.com

APAC

**SPX FLOW TECHNOLOGY
SHANGHAI OFFICE**

1568 Hua Shan Road
5F Treasury Building
Changning District
Shanghai 20052 - PR China
Phone: +86 21 2208 5858
E-Mail: asia.pacific@spxflow.com

For more locations please visit: <http://branluebbe.com>.

SPX FLOW reserves the right to incorporate our latest design and material changes without notice or obligations.

Design features, materials of construction and dimensional data, as described in this bulletin, are provided for your information only and should not be relied upon unless confirmed in writing. Please contact your local sales representative for product availability in your region. For more information visit www.spxflow.com.

The green "b" and "x" are trademarks of SPX FLOW, Inc.