



Durco[®] Mark 3[™] ISO Chemical Process Pumps

ISO 2858/5199/15783



Experience In Motion



Solving the world's toughest pumping challenges

The most aggressive fluids and chemicals on the planet. High-temperature and high-pressure applications that test the limits of hydraulic and mechanical design. Those are the pumping challenges our customers face every day and that's where you'll find Flowserve pumps performing efficiently, safely and reliably. It's a legacy that goes back centuries — one we build upon every day.

Our industry-leading portfolio of pumps is only part of the story, though. Our customers need answers that demand extensive know-how and experience, and we've got it. More than 18 000 committed associates are your go-to resources for expert engineering, project management, technical support and service in every corner of the world.

Tackling new challenges head on

Operating parameters change, energy costs fluctuate, environmental factors evolve and competitive landscapes shift. You face new challenges every day. Flowserve helps your team identify emerging issues and develop solutions that streamline processes, maximize production, promote safety and boost your bottom line.

Services that ensure your success

Timely service is a key priority to your operations, so we've made it a key priority of ours. Our global network of Quick Response Centers and mobile service fleet helps to minimize downtime with hands-on support that's fast and dependable, regardless of OEM.

Driving performance and safety

Maximizing performance is critical to your bottom line, but it can't come at the expense of personnel or environmental safety. We've pioneered important advancements in pump technology that improve performance while reducing power consumption and environmental risks. Our products are designed for uncompromising safety and reliability — all to help you maximize pump availability and keep plant personnel and assets safe.

The premier name in chemical process pumps

You need outstanding hydraulic performance, proven reliability and low total cost of ownership out of a chemical process pump. The Durco Mark 3 ISO pump delivers. Conforming to ISO 2858, ISO 5199 and ISO 15783 design criteria, the Durco Mark 3 ISO incorporates many proven reliability- and performance-enhancing features to meet the varied needs of the global process industries:

- Lower energy usage ensured by high-efficiency performance over the life of the pump
- Extensive hydraulic options and coverage for demanding process fluids
- Minimized downtime, maximized working life and low maintenance costs
- Application flexibility due to the standardized modular system design
- High environmental and personnel safety during operation and maintenance
- Versatile platform for plant-specific seals, accessories and instrumentation systems

Configurations to meet all your application needs

Durco Mark 3 ISO process pumps are available in sealed and sealless designs that can be configured to your precise application requirements.

Mechanically sealed

- Long coupled
- Close coupled
- Self-priming
- Recessed impeller
- Centerline mounted
- Vertical sump

Sealless, magnetic drive

- Long coupled
- Close coupled
- Heat barrier



Typical applications

- Acid transfer
- Brine
- Chemical processing
- Corrosive services
- Food and beverage processing
- Hydrocarbon processing
- Petrochemical processing
- Pharmaceuticals
- Polymers
- Pulp and paper
- Sea water
- Slurries
- Solvents
- Steel and primary metals
- Water and wastewater treatment

Mark 3 ISO | Mechanically Sealed

Durco Mark 3 ISO mechanically sealed pumps are the standard bearer for ISO chemical process pumps. They are recognized worldwide for their ability to tackle the most demanding applications with exceptional performance, efficiency and reliability. And, maintenance-friendly features such the external micrometer impeller adjustment mechanism, reverse vane impeller and true back pullout design keep your total cost of ownership low.

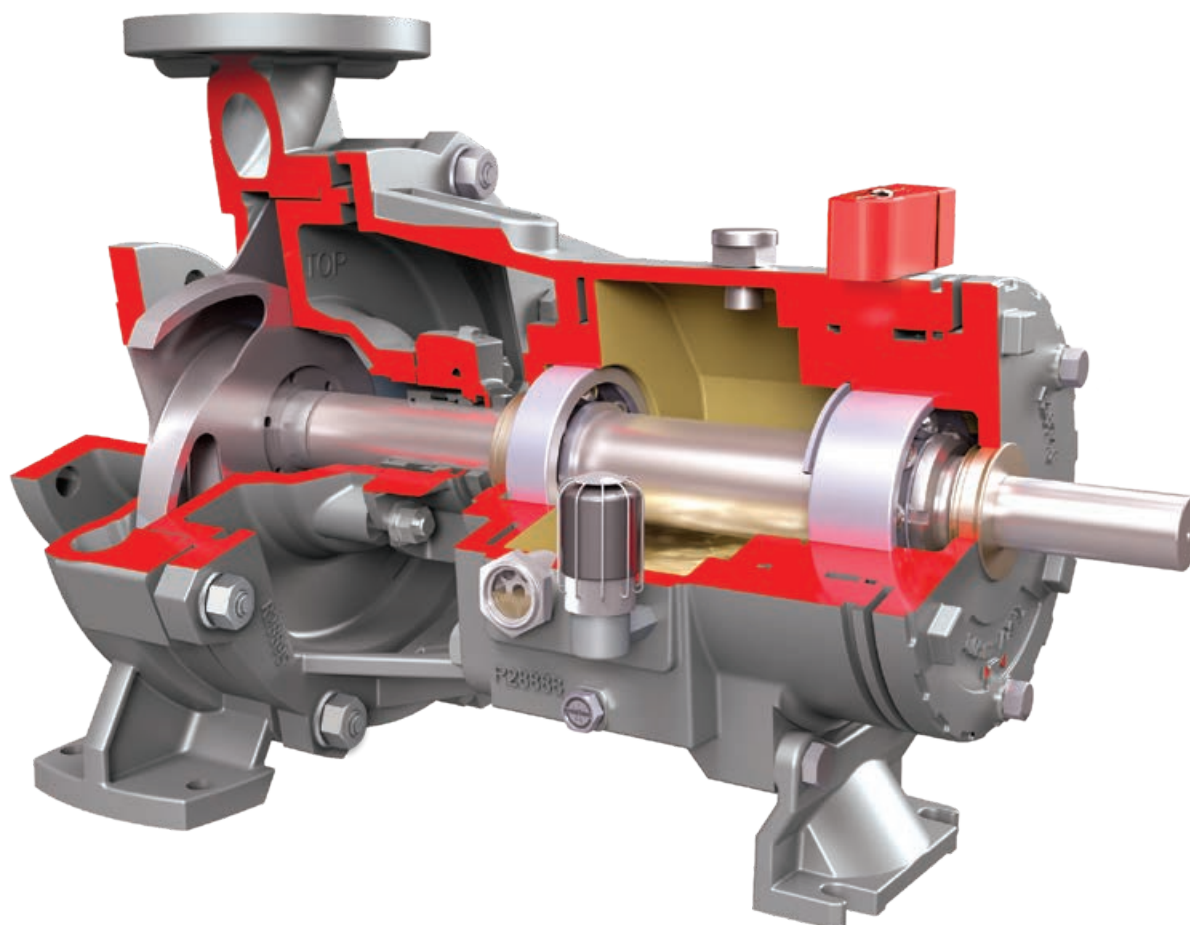

Operating parameters

- Flows to 1400 m³/h (6160 US gpm)
- Heads to 220 m (720 ft)
- Pressures to 25 bar (365 psi)
- Temperatures from -80°C to 400°C (-110°F to 752°F)
- Discharge sizes from 20 to 200 mm (0.75 to 8 in)

Standards compliance

Durco Mark 3 ISO mechanically sealed pumps conform to ISO 2858 and ISO 5199 design criteria and are CE marked. Compliance with the following directives is also available:

- ATEX (2014/34/EU)
- Food grade (1935/2004/EC)
- Drinking water (98/83/EC)
- CUTR

Designed for demanding applications

High-pressure components, a generous corrosion allowance and a wide range of materials of construction are just some of the features and options that ensure Durco Mark 3 ISO pumps perform reliably under demanding conditions.

- ISO 2858 and extended flow hydraulics
- Standard (16 bar; 232 psi) or high-pressure (25 bar; 363 psi) casing
- Advanced SealSentry™ seal chambers (see page 12 for more details)
 - Self-flushing, -venting and -draining designs with flow modifiers extend mechanical seal life
 - Accommodate a wide variety of seal types
 - Standard high-pressure (25 bar; 363 psi)
- 3 mm (0.12 in) corrosion allowance
- Corrosion- and erosion-resistant wet end materials
- Available centerline mounted casing
- Available drain, gauge and recirculation connections

External micrometer simplifies maintenance

Whether in the shop or the field, the external micro-meter impeller adjustment mechanism enables your maintenance staff to accurately set the clearance for open or reverse vane impellers in 20 seconds.

Condition monitoring improves uptime

Many Durco Mark 3 ISO pumps are available with the IPS Beacon™ 2 power end condition monitor. This light fault device enables plant personnel to quickly see which assets need maintenance so service can be scheduled and uptime maximized.

Cast bosses make installing additional IPS performance monitoring products quick and easy.

See page 22 for a list of condition and performance monitoring options.

Minimize maintenance costs by maximizing MTBM

Maintenance and downtime costs are a huge part of the total cost of ownership, so it's critical to keep them low. The Durco Mark 3 ISO incorporates numerous maintenance- and reliability-enhancing features to do just that.

- True back pullout design
- In-shop impeller adjustment of open and reverse vane impellers with external micrometer
- Patented multi-port bearing carrier
- Machinable rear cover (primary wear surface for reverse vane impeller)
- Robust power end (see page 10 for more details)
 - Shaft deflection less than 0.05 mm (0.002 in) at the seal faces
 - Standard bearings with L10h bearing life of 17 500+ hours



Mark 3 ISO | Mechanically Sealed

Configurations

We know you have many different types of applications in your plant. That's why we offer the Durco Mark 3 ISO pump in four mechanically sealed configurations. All use the same energy-efficient hydraulics that deliver high performance and reliability with low energy costs. Available in a variety of materials of construction and with single, double or cartridge seals to suit application requirements.

Long coupled

The workhorse of chemical plants and other industries around the world, this proven model is ideal for handling aggressive liquids. Its back pullout design minimizes downtime by enabling removal of the rotating element without disturbing the casing, piping or motor. 45 sizes available.

Operating parameters

Flows to: 1400 m³/h (6160 gpm)
Heads to: 220 m (720 ft)
Pressure to: 25 bar (365 psi)
Temperature: -80°C to 400°C (110°F to 752°F)



Close coupled

Durco Mark 3 ISO close coupled pumps provide a compact arrangement ideal for installations where space is at a premium. They are fitted with readily available standard electric motors, so you can choose an enclosure to suit the application. 37 sizes available.

Operating parameters

Flows to: 570 m³/h (2500 gpm)
Heads to: 100 m (330 ft)
Pressure to: 25 bar (365 psi)
Temperature: -20°C to 160°C (-5°F to 320°F)

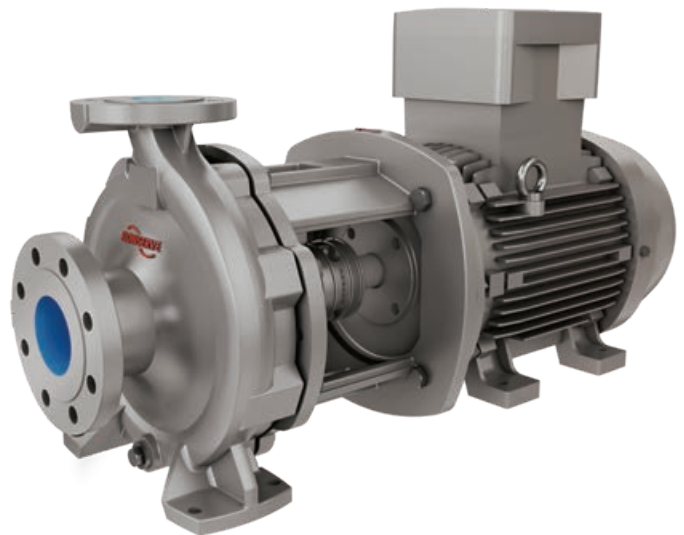

Self-primer

Costing less to buy, install and maintain than submersible pumps, Durco Mark 3 ISO unitized self-priming pumps are designed to draw liquid from sources below ground level or with no positive pressure to naturally prime the pump. 7 sizes available.

Operating parameters

Flows to: 100 m³/h (440 gpm)
Heads to: 100 m (330 ft)
Pressure to: 25 bar (365 psi)
Temperature: -80°C to 400°C (110°F to 752°F)



Recessed impeller

Combining a wide clearance casing with a vortex action that ensures less than 20% of the process fluid contacts the impeller, the recessed impeller pump is well suited for applications with larger particles, stringy or fibrous slurries, or friable solids that require low shear pumping. 10 sizes available.

Operating parameters

Flows to: 750 m³/h (3300 US gpm)
Heads to: 100 m (330 ft)
Pressures to: 25 bar (365 psi)
Temperature: -80°C to 400°C (110°F to 752°F)

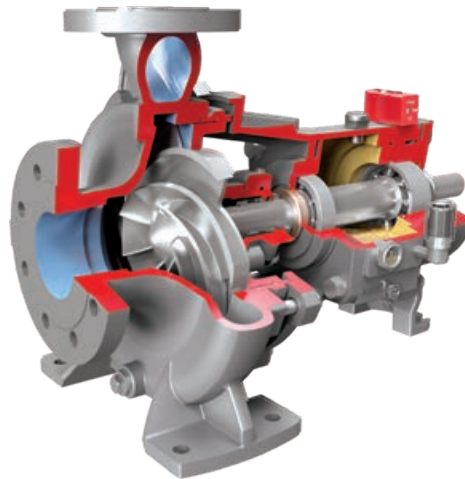

Vertical sump

With column lengths up to 10 m (32 ft), Durco Mark 3 ISO vertical sump pumps can be customized to meet a wide range of needs. For oil and gas installations, they are offered with many ISO 13709/API 610 compliant features. 40 sizes available.

Operating parameters

Flows to: 1400 m³/h (6160 gpm)
Heads to: 250 m (820 ft)
Pressure to: 25 bar (365 psi)
Temperature: -40°C to 400°C (-40°F to 752°F)



Mark 3 ISO | Mechanically Sealed

Impellers

Durco Mark 3 ISO mechanically sealed pumps are available with four impeller types to accommodate a range of processes. Available in a variety of corrosion- and abrasion-resistant materials to suit application needs.



Reverse vane impeller

Safety, efficiency and ease of maintenance are the driving principles of the reverse vane impeller. With only one critical clearance that can be reset with no replacement parts or a need to open the pump wet end, the reverse vane impeller is ideally suited for hazardous process fluids.

Operating performance

- ISO 2858 and extended flow
- Solid handling capability
 - Max solid size 28 mm (1.1 in)
 - Max soft solid 35%
 - Max hard solid 10%



Open impeller

Fully interchangeable with the reverse vane impeller, the open impeller is a single shroud with a Francis vane design and is the preferred choice for fibrous or stringy applications which may block the internal passage of other impeller designs.

Operating performance

- ISO 2858 and extended flow
- Solid handling capability
 - Max solid size 25 mm (1.0 in)
 - Max soft solid 35%
 - Max hard solid 10%
 - Max paper stock 10%

When used in the recessed impeller pump configuration, which boasts a wide clearance casing, the open impeller is able to handle solids up to 46 mm (1.8 in).

Operating performance

- Solid handling capability
 - Max solid size 46 mm
 - Max soft solid 35%
 - Max hard solid 10%
 - Max paper stock 3%



Closed impeller

For clean process fluids, the closed impeller offers high efficiency with low NPSHR. Replaceable wear rings during routine maintenance easily restore hydraulic performance. Available for sealed and sealless designs, the closed impeller is a highly modular interchangeable solution.

Operating performance

- ISO 2858
- Solid handling capability
 - Max solid size 0.3 mm (0.01 in)
 - Max soft solid 2%
 - Max hard solid 2%
 - Max paper stock 1%

Impeller interchangeability

Configuration	Reverse Vane	Open	Closed
Long Coupled	•	•	•
Close Coupled	•	•	•
Self-Primer		•	
Recessed Impeller		•	
Vertical		•	

Mark 3 ISO | Mechanically Sealed

Power ends

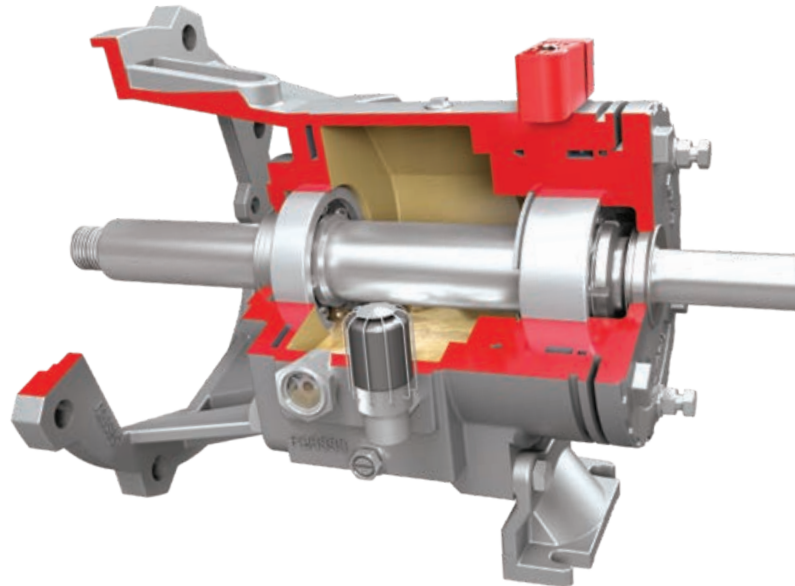

Long coupled

The Durco Mark 3 ISO long coupled power end is a versatile platform that helps maximize uptime and reduce total cost of ownership. The two-piece bearing housing and adapter design has many maintenance-friendly features and is interchangeable with Durco Mark 3 ISO MAG power ends.

Features:

- Two-piece design with metal-to-metal fit ensures true running for extended bearing and seal life
- Non-contacting bearing isolators keep lubricants in and dirt out for an ideal bearing environment
- Ductile cast iron construction is more robust than gray cast iron; stainless steel available
- Impeller setting with precision external micrometer adjustment
- Large oil sump with multiple oil or grease lubrication options
- Magnetic drain plug
- Large 25 mm (1 in) sight glass
- Top-mounted vent and oil filler
- Guaranteed L10h bearing life of 17 500 hours; optional L10h bearing life of 50 000+ hours

Options

The long coupled power end is available with the following options designed to improve reliability and extend maintenance intervals.

Bearings

For improved load-handling characteristics in demanding applications, the standard single-row ball bearing (inboard) and double-row angular contact ball bearing can be easily upgraded to a roller bearing (inboard) and duplex double-row angular contact ball bearing (outboard).



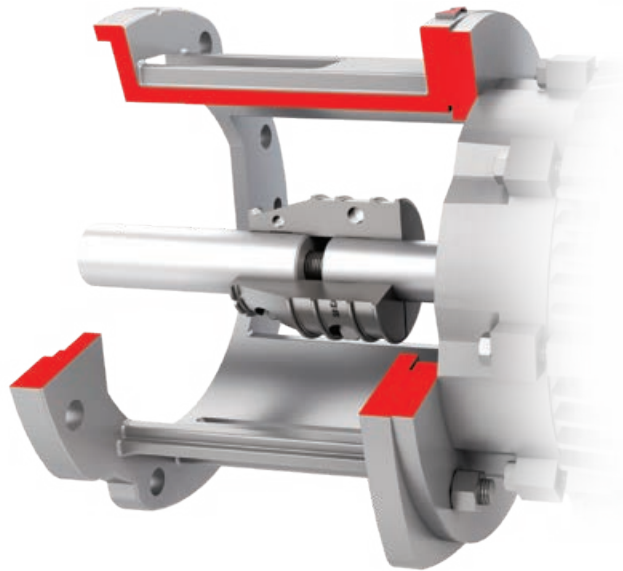

Close coupled

The close coupled power end is ideally suited for installations where space is limited. It utilizes adapters to directly connect the wet end to a standard motor, eliminating the bearing housing. Various mounting installations are possible, including the use of the pump's inlet and outlet piping.

Features:

- Compact footprint is ideal for installations where space is at a premium
- Adapters interface directly with standard electric motors
- Ductile cast iron construction is more robust than gray cast iron
- No bearing housing minimizes maintenance needs and costs
- Sturdy design reduces installation costs by removing baseplate requirement
- Impeller setting with precision external micrometer adjustment

Lubrication

You have a wide range of lubrication options with the Durco Mark 3 ISO pump. Combined with the pump's large oil sump, they ensure low maintenance costs and downtime with up to 36 months between oil changes. Options include:

- Oil splash bath — mineral or synthetic
- Grease — mineral, synthetic or food grade
- Oil mist (pure or purge)
- Nitrogen purge over oil sump

Bearing Gard™

Prevent contamination during shutdown. Flowserve Bearing Gard bearing isolators incorporate static sealing technology that keeps contaminants from entering the bearing housing of long coupled units when not operating. Upon startup, the static sealing system transitions to non-contacting operation for permanent non-wearing performance. Alternative bearing isolators can be supplied.



Mark 3 ISO | Mechanically Sealed

Seal chambers and seals

Seal failure is the biggest cause of pump downtime. Durco SealSentry seal chambers accommodate a variety of seal types and help you maximize MTBM and pump uptime.

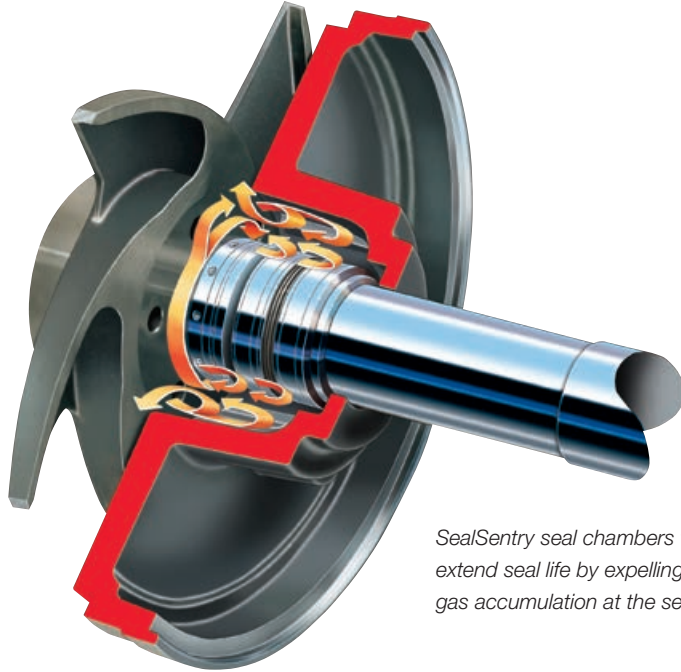

SealSentry seal chambers with flow modifiers extend seal life by expelling solids and preventing gas accumulation at the seal faces.

Conical bores with flow modifiers boost the bottom line

Conical bore SealSentry seal chambers are preferred for most applications. Flow modifiers redirect fluid flow so solids are flushed out of the seal chamber and gases are not trapped at the seal faces. Seal performance and reliability are improved. Less costly seals and flush plans can be used. Flush plans 11, 31 and 32 can be eliminated. The result is higher uptime with lower ownership costs.

Available in several bore sizes and gland bolt circles, the conical design is ideal for:

- Single internal cartridge seals
- Dual internal/external cartridge seals
- Single internal component seals with flexible mounted seats
- Dual internal “true” tandem design cartridge seals
- Single seals with all seat mounting configurations

Available cylindrical bore designs

With oversized and standard bores available, cylindrical bore seal chambers are well-suited for packing arrangements and conventional seals with small gland bolt and gasket circles. They also may be used with:

- Dual internal component seals using external barrier fluid
- Single seals with throttle bushings and flushes to boost pressure over the flash point

Flush plans

Optimum seal conditions are maintained with a range of ISO 21049/API 682 piping plans. Proper flush plan selection is dependent on the seal chamber design used. Consult Flowserve engineering to determine which flush plan best suits your application.

Options

Materials of construction

Safe, reliable fluid handling over a wide range of processes is achieved by the Durco Mark 3 ISO pump's many available wet end materials. Options include:

- Cast iron
- Ductile iron
- Carbon steel
- 304 stainless steel
- 316 stainless steel
- Duplex and super duplex stainless steels
- Alloy 20
- Nickel and nickel-based alloys such as Alloy C-276 and Alloy B2
- Reactive alloys such as titanium, palladium stabilized titanium and zirconium
- Special materials available upon request

Flanges

Five standard flange sizes complying with EN1092-1, EN 1092-2, EN 1759-1 and EN 1759-2 standards enable easy conformance to site pipework standards for simple installation without the need for pipework adapters.

Paint

The correct paint system can make a big difference in a pump's working life, particularly in aggressive environments. The Durco Mark 3 ISO pump is offered with a range of paint systems, including those compliant with the ISO 12944 requirement of "long-term protection – up to 15 years to first maintenance".

Food or drinking water compliance

The Durco Mark 3 ISO is available in versions that are compliant with applicable food and drinking water regulations. These versions ensure safe, reliable pumping of food or water that doesn't endanger human health, or impact composition, taste or odor. Components meet applicable standards and are traceable.

- **Food:** Components in contact with the process fluids are manufactured to the requirements of EC 1935/2004.
- **Potable water:** Certification can be provided to national standards such as Regulations 31 and 33 (United Kingdom) and KTW (Germany).

Low- or high-temperature applications

The Durco Mark 3 ISO pump is able to provide reliable continuous performance in applications with extreme ambient and/or process liquid temperatures. Numerous options are available to ensure safety and maximize MTBF under these demanding operating conditions.

- Centerline mounted casings
- Jacketed casings and seal chambers
- Austenitic stainless steel bearing housings
- Heat tracing
- Air or liquid bearing housing cooling options
- Application-specific gaskets, O-rings, lubricants and paint systems



Mark 3 ISO MAG | Sealless Magnetic Drive

We know safety isn't an option; it's a necessity. For maximum personnel and environmental safety, Durco Mark 3 ISO MAG sealless magnetic drive pumps provide dependable, leak-free performance in all types of applications. They are particularly well-suited for applications involving toxic, explosive and valuable liquids.

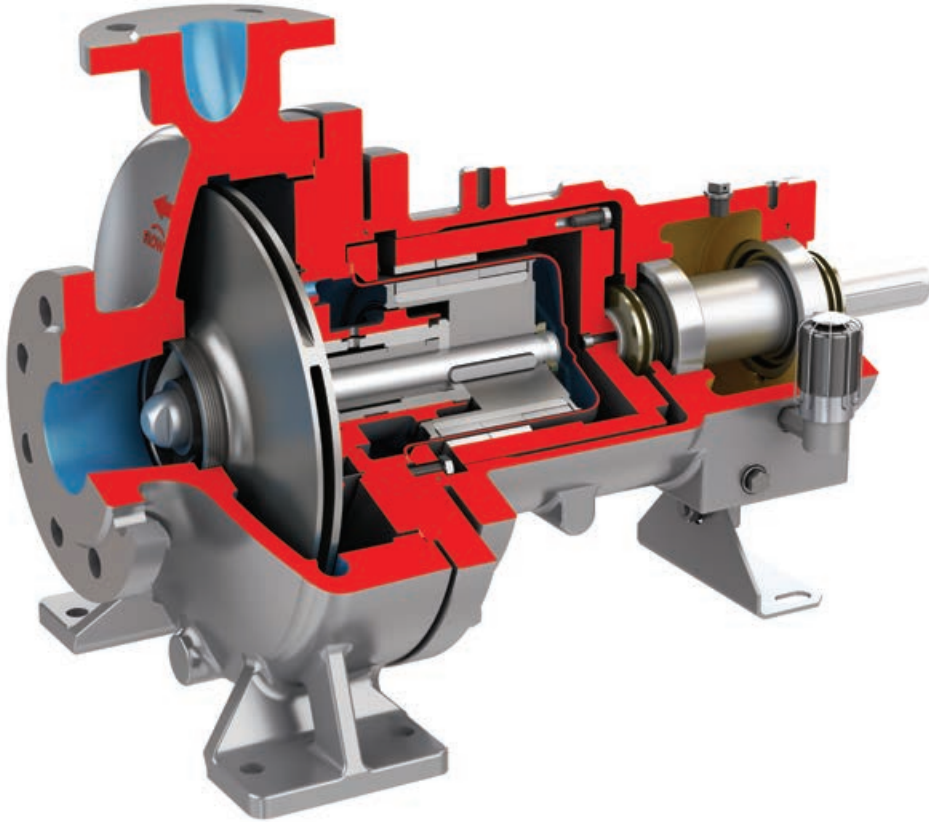

Operating parameters

- Flows to: 475 m³/h (2091 gpm)
- Heads to: 150 m (492 ft)
- Pressure to: 25 bar (365 psi)
- Temperature
 - Closed lantern bracket: to 200°C (392°F)
 - Open lantern bracket: to 350°C (662°F)
 - Heat barrier design: to 400°C (752°F)
- Discharge sizes from 25 to 150 mm (1 to 6 in)

Standards compliance

Durco Mark 3 ISO MAG pumps conform to ISO 2858, ISO 5199 and ISO 15783 design criteria and are CE marked. Compliance with the following directives is also available:

- ATEX (2014/34/EU)
- Food grade (1935/2004/EC)

Flanges

- Dimensions to PN 16 or PN 25
- Drilled to ASME 150 RF or 300 RF

Low total cost of ownership with reliable, energy-efficient design

Durco Mark 3 ISO MAG pumps incorporate many features that improve reliability and efficiency. The results are long service life and low ownership costs.

- Optimized hydraulics with no diffuser losses keeps power consumption low
- Steady partial flow keeps magnets cool and bearings lubricated
- Temperature-stable magnetic system up to 350°C (662°F)
- Maintenance-free sleeve bearings
- Robust bearing system extends MTBF
- Standard bearings with L10h life of 50 000 hours
- An engineered running clearance maintains safe operation in case of bearing failure or shaft misalignment
- Multiple oil and grease lubrication options
- Available secondary control system per ISO 15783

Interchangeable with mechanically sealed configurations

Durco Mark 3 ISO MAG pumps are built to the same end-to-end dimensions as the standard mechanically sealed pumps. Converting one to the other is as simple as dropping in the preferred model.

Condition monitoring improves pump availability

Many Mark 3 ISO MAG pumps come equipped with the IPS Detect™ online condition monitor. This light fault device enables plant personnel to quickly see which assets are in need of attention.

Cast bosses make installing additional IPS performance monitoring products quick and easy.

See page 22 for a list of condition and performance monitoring options.

Two back pullout options make maintenance safe and easy



Standard back pullout

The standard back pullout feature simplifies your general maintenance and inspection tasks. The casing stays in-line and piping connections remain intact, saving time.



Contained back pullout

When drive end maintenance is needed, the contained back pullout feature saves you valuable time without sacrificing safety. The process fluid is fully confined in the wet end, which remains intact. The need to drain or purge the pump is eliminated, so maintenance personnel are safe from exposure to potentially harmful process fluids.

Mark 3 ISO MAG | Sealless Magnetic Drive

Configurations

Safety isn't one-size-fits-all, so we offer three configurations of Durco Mark 3 ISO MAG pumps. Optimized hydraulics and a hermetically sealed design with true back pullout deliver safe, leak-free performance with low energy costs. Available in a variety of materials — including metallic or ceramic containment shells — to suit application needs.

Long coupled

This versatile magnetic coupling chemical process pump is very well-suited for handling toxic, explosive and valuable liquids in nearly all industries. The contained back pullout feature ensures personnel safety while minimizing downtime. 35 sizes available.

Operating parameters

Flows to: 475 m³/h (2091 gpm)
Heads to: 150 m (492 ft)
Pressure to: 25 bar (365 psi)
Temperature: -70°C to 350°C (-94°F to 662°F)



Close coupled

The compact proportions of the Durco Mark 3 ISO MAG close coupled pump make it ideal for installations where space is at a premium. It provides safe, zero-leakage performance of fluids up to 350°C (662°F) without cooling. Standard electric motors keep ownership costs low. 35 sizes available.

Operating parameters

Flows to: 475 m³/h (2091 gpm)
Heads to: 150 m (492 ft)
Pressure to: 25 bar (365 psi)
Temperature: -70°C to 350°C (-94°F to 662°F)



Heat barrier

Durco Mark 3 ISO MAG heat barrier pumps handle thermal fluids up to 400°C (752°F) with zero leakage and without cooling. This close coupled configuration uses standard electric motors to keep ownership costs low. Standard TiN-coated ZrO₂ ceramic containment shell generates zero eddy current losses for greater temperature control. Closed lantern bracket on power end only; open lantern bracket not available. 35 sizes available.

Operating parameters

Flows to: 475 m³/h (2091 gpm)
Heads to: 150 m (492 ft)
Pressure to: 25 bar (365 psi)
Temperature: -40°C to 400°C (-40°F to 752°F)



Closed impeller

All Durco Mark 3 ISO MAG sealless magnetic drive pumps use a closed impeller. In clean process fluids, the closed impeller offers high efficiency with low NPSHR. Available replaceable wear rings restore hydraulic performance and extend pump life.

Operating performance

- ISO 2858
- Solids-handling capability
 - Max solid size: 0.3 mm
 - Max soft solid: 2%
 - Max hard solid: 2%
 - Max paper stock: 1%



Mark 3 ISO MAG | Sealless Magnetic Drive

Power ends

Long coupled

The standard power end for the Durco Mark 3 ISO MAG is a robust one-piece, long coupled design. Ductile cast iron construction with oversized ball bearings helps maximize uptime. Available with either oil or greased-for-life lubrication. Interchangeable with mechanically sealed Durco Mark 3 ISO power ends.

Features

- Oversized ball bearings with L10h life up to 50 000+ hours available
- Available with open or closed bearing bracket connecting the pump to the motor (closed design shown)
- Magnetic drain plug
- Different oil seal options
- Optional secondary control system per ISO 15783
- Available drain, gauge and recirculation connections

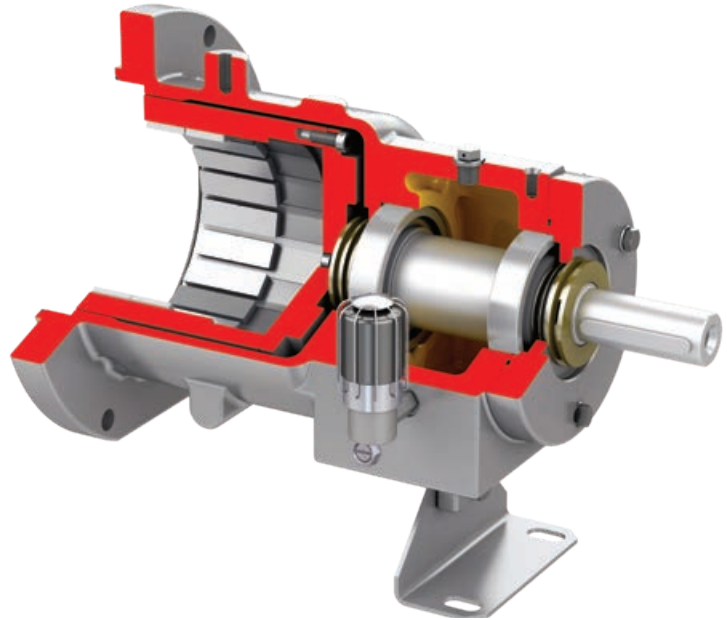

Close coupled

The close coupled power end is ideal for installations where space is limited. By utilizing an adapter to directly connect the wet end to a standard electric motor, it eliminates the bearing housing — and the maintenance that goes along with it. And, because of its compact, sturdy design, a baseplate is not required.

Features

- Maintenance-free design with no bearing housing
- Available with open or closed lantern bracket connecting the pump to the motor (closed lantern shown)
- Optional secondary control system per ISO 15783
- Available drain, gauge and recirculation connections
- Available heat barrier configuration with closed lantern bracket for high-temperature applications (refer to page 17)



Power end options

Pumps fitted with the long coupled power end are available with the following options to improve reliability and extend maintenance intervals. Additional options are available.

Lubrication systems

You have a wide range of lubrication options with long coupled Durco Mark 3 ISO MAG pumps. Options include:

- Oil splash bath — mineral or synthetic
- Grease — mineral, synthetic or food grade

Bearing Gard bearing isolators

Flowserve Bearing Gard bearing isolators prevent contamination during shutdown. They incorporate static sealing technology that keeps contaminants from entering the bearing housing of long coupled units when not operating. Upon startup, the static sealing system transitions to non-contacting operation for permanent non-wearing performance.

Flowserve Bearing Gard isolators are standard equipment on all Mark 3 ISO MAG pumps. Alternative bearing isolators are available.



Mark 3 ISO MAG | Sealless Magnetic Drive

Containment shells

Durco Mark 3 ISO MAG pumps are available with three containment shell options. Differences among them involve materials of construction, efficiency (eddy current losses) and application temperatures. All containment shells are rated to PN 25, ATEX approved, and fully interchangeable.

Standard Alloy C-4 shells

Mark 3 ISO MAG pumps come standard with Alloy C-4 containment shells. They provide excellent corrosion resistance and meet PN 25 pressure rating. Two options are available, depending on application temperature.

High-efficiency shells

When process fluids are sensitive to heat but not corrosive, high-efficiency shells provide an advantage. Also made of Alloy C-4, these shells offer significant reductions in power consumption.

- Approximately 40% reduction in eddy current losses
- Approximately 5% increase in coupling efficiency
- Temperatures to 180°C (356°F)

TiN-coated ZrO₂ ceramic shells

For the toughest applications, Mark 3 ISO MAG pumps are specified with TiN-coated ZrO₂ ceramic shells. These shells possess excellent corrosion resistance and, being non-metallic, generate zero eddy current losses. They are well-suited for applications in which the process fluid is corrosive and/or abrasive as well as temperature sensitive.

- Superior corrosion and abrasion resistance
- No eddy current losses
- High fracture toughness and thermal shock resistance
- ATEX compliant
- Suitable for temperatures to 200°C (392°F) with closed lantern bracket on power end; to 400°C (752°F) with heat barrier configuration



Options

Higher torque design

For applications requiring torque transmission in excess of ISO 2858 limits, Flowserve offers a higher torque design. This model employs an additional magnetic system with extended f-dimension to deliver torque up to 381 Nm (281 ft-lb).

Sleeve bearing

Mark 3 ISO MAG pumps come standard with SSiC (sintered silicon carbide) sleeve bearings. Options include:

- SiC — high chemical resistance, hardness, and strength; 100% maintenance free
- For low-lubricity fluids, special material combinations are available.

Flush systems

Three flush options are available with the Durco Mark 3 ISO MAG pump.

- Internal flow with implemented strainer as standard
- Free-flow filter for contaminated fluids
- External partial flow

Paint

The right paint system paint can make a considerable difference in a pump's working life. The Durco Mark 3 ISO MAG pump is offered with a range of paint systems, including ISO 12944 compliant options that provide long-term protection.

High-temperature applications

Durco Mark 3 ISO MAG pumps provide reliable, continuous performance in applications to 400°C (752°F) when fitted with heat barrier power ends. Additional options for high-temperature applications include:

- TiN-coated ZrO₂ containment shells
- High-pressure (25 bar/363 psi) casings
- Ductile iron lantern bracket

Low-temperature applications

For applications with low ambient or fluid temperature, the following options ensure safe, reliable operation.

- Heat tracing
- Jacketed casings and covers
- Austenitic stainless steel bearing housings

Secondary control system

In accordance with ISO 15783, Flowserve offers an optional secondary control system for long coupled and closed coupled configurations. In the event of a leak, this system minimizes and safely directs the release of pumped liquid. It includes the following components:

- Leak detector
- Secondary shaft seal
- Drain plug

Secondary control can only be provided with a closed bearing bracket (long coupled) or closed lantern bracket (close coupled).

Accessories

IPS condition and performance monitoring products

Condition monitors

Economical, easy to install and maintain, with local data logging and short-range Bluetooth® wireless and local visual alert capabilities to optimize maintenance practices.



IPS Beacon™ 2



IPS Beacon Pulse™

Wireless

Cost-effective, long-range wireless data acquisition and transmission, providing information for equipment maintenance optimization and condition monitoring.



IPS Node™



IPS Multi-Port 103

Predictive analysis

High-speed data acquisition and predictive analytic capabilities for flow control equipment.



IPS APEX™



IPS Detect™

IPS Mobile Insight™

Access real-time equipment performance data on a handheld device, configure devices while in the field, and upload field data to the cloud with the touch of a button.



The Bluetooth® word mark and logos are registered trademarks owned by the Bluetooth SIG, Inc. and any use of such marks by Flowserve is under license. Other trademarks and trade names are those of their respective owners.

IPS Insight platform

Cloud-based or locally hosted platform leveraging deep predictive analytics based on both OEM engineering algorithms and machine learning to help optimize system performance, better understand potential failure modes, and help avoid unplanned downtime. Not only can you now know when an asset might fail, but also how it might fail.



Seal support systems

Flowserve seal support systems help ensure years of reliable mechanical seal operation and operating cost savings. Flowserve employs a specialized engineering team with years of experience designing and selecting seal support systems to suit unique applications, specifications and customer requirements. With a full range of products that meet ASME, API, PED, ISO and NR13 design criteria, Flowserve addresses the global needs of the oil and gas, chemical, power, water and general industries.

- Buffer/barrier fluid reservoirs
- Bladder accumulators
- Piston accumulators
- Buffer/barrier gas panels
- Water or air seal coolers
- Circulators



Baseplates

Flowserve offers four pre-engineered baseplates that improve pump performance while reducing maintenance costs. These rigid baseplate designs reduce internal stresses and vibration on pump and motor packages to extend their working life.

Pump users specify rigid baseplate designs to:

- Provide torsional lateral and longitudinal rigidity
- Improve vibration dampening
- Protect against transit damage
- Resist twisting during installation
- Maintain shaft alignment
- Reduce installation and shaft alignment time
- Reduce diaphragming or separation from grout
- Improve pump, motor and seal reliability
- Reduce total lifecycle pump, motor and seal costs

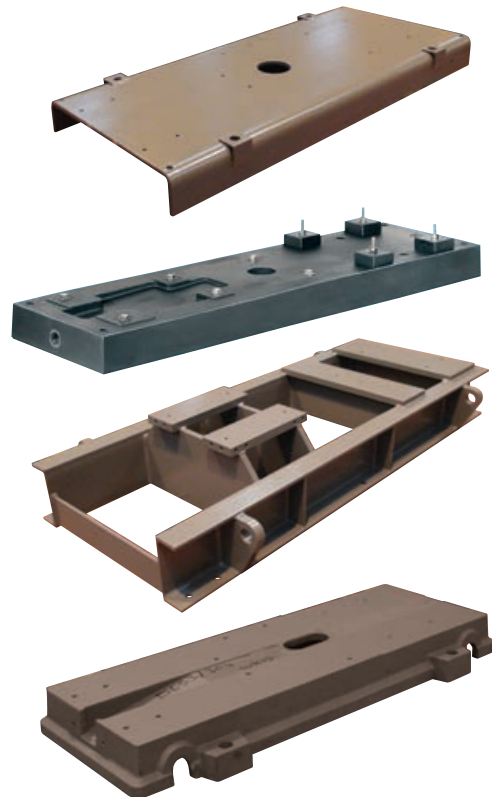

Complementary products

Sealed — ASME — standard flow

Durco Mark 3

ASME B73.1 chemical process pump for corrosive applications in chemical, petrochemical, hydrocarbon and pharmaceuticals processing environments requiring unequaled efficiency, extended life and repeatable pump performance.

- Flows to 1700 m³/h (7500 gpm)
- Heads to 300 m (990 ft)
- Pressure to 27 bar (400 psi)
- Temperature -73°C to 370°C (-100°F to 700°F)



Sealed — ASME — extended flow

Durco Mark 3 Group 4

High-capacity chemical process pump offers increased capacity with proven Durco performance and reliability along with ASME B73.1 design features.

- Flows to 3861 m³/h (17 000 gpm)
- Heads to 125 m (410 ft)
- Pressure to 19 bar (275 psi)
- Temperature -73°C to 204°C (-100°F to 400°F)



Sealed — ASME — vertical

Durco ESP3

This ruggedly built, vertical chemical sump pump is designed to provide improved performance, increased part standardization and reduced inventory costs.

- Flows to 1300 m³/h (5700 gpm)
- Heads to 116 m (380 ft)
- Pressure to: 12 bar (175 psi)
- Temperature to 180°C (350°F)



Sealed — ISO — extended flow

SIHI® CBT

Single-stage pump with ISO 2858/5199 design features and nominal rating. Engineered for applications in chemical, petrochemical and pharmaceuticals processing with flows beyond the range defined by ISO 2858.

- Flows to 2200 m³/h (9686 gpm)
- Heads to 160 m (524 ft)
- Pressure to 25 bar (362 psi)
- Temperature -20°C to 350°C (-4°F to 662°F)



Sealed – ISO – extended flow

SIHI RBS

Single-stage pump with ISO 5199 design features and nominal rating. Engineered for applications in chemical, petrochemical and pharmaceuticals processing.

- Flows to 1200 m³/h (5283 gpm)
- Heads to 150 m (492 ft)
- Pressure to 40 bar (580 psi)
- Temperature to 400°C (752°F)

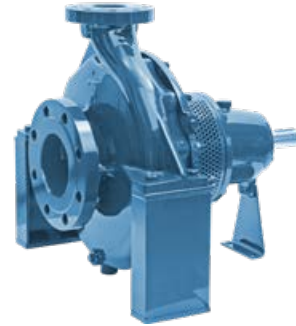

Sealless – ASME – metallic

Durco Guardian™

Metallic sealless magnetic drive pump compliant with ASME B73.1, ASME B73.3 and HI 5.1-5.6 that is designed for applications requiring efficient performance and emissions-free reliability.

- Flows to 375 m³/h (1650 gpm)
- Heads to 215 m (700 ft)
- Pressure to 24 bar (350 psi)
- Temperature to 290°C (550°F)



Sealless – ASME or ISO – lined

INNOMAG® TB-MAG™ ANSI, ISO

ASME B73.3 or ISO 2858 compliant thrust-balanced, fluoropolymer-lined, magnetic drive pump for chemical processing, metals and other industries seeking outstanding leak protection and reliability.

- Flows to 360 m³/h (1585 gpm)
- Heads to 153 m (500 ft)
- Pressure to 25 bar (362 psi)
- Temperature -29°C to 121°C (-20°F to 250°F)



U-MAG™

Versatile fluoropolymer-lined, magnetic drive pump for smaller-volume applications needing exceptional safety, enhanced performance and highest purity standards.

- Flows to 102 m³/h (450 gpm)
- Heads to 50 m (165 ft)
- Pressure to 20 bar (300 psi)
- Temperature -29°C to 121°C (-20°F to 250°F)



Dedicated local support, worldwide

When and where you need us

Our network of manufacturing facilities, design centers of excellence, strategically located Quick Response Centers and customer on-site resources means customers never have to look far for support.



Services that drive safety, reliability and performance

Flowserve offers a comprehensive suite of services designed to provide unprecedented value and cost savings throughout the life span of the system. By integrating hydraulic, mechanical and materials engineering knowledge with real-world operating and practical business solutions, Flowserve helps customers:

- Increase equipment reliability
- Optimize asset uptime and performance
- Improve plant and personnel safety
- Lower total cost of maintenance



Lifecycle cost solutions

Typically, 90% of the total lifecycle cost (LCC) of a pumping system is accumulated after the equipment is purchased and installed. Flowserve has developed a comprehensive suite of solutions aimed at providing customers with unprecedented value and cost savings throughout the life span of the pumping system. These solutions account for every facet of lifecycle cost, including:

Capital expenses

- Initial purchase
- Installation

Operating expenses

- Energy consumption
- Maintenance
- Production losses
- Environmental
- Inventory
- Operating
- Removal

Innovative lifecycle cost solutions

- New pump selection
- Turnkey engineering and field service
- Energy management
- Pump availability
- Proactive maintenance
- Inventory management

Typical pump lifecycle costs¹

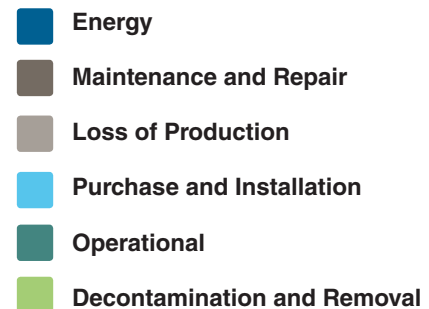
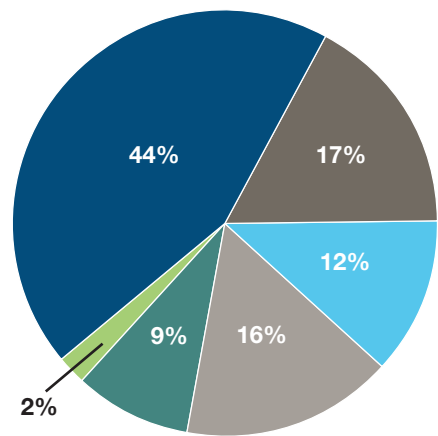

¹ While exact values may differ, these percentages are consistent with those published by leading pump manufacturers and end users, as well as industry associations and government agencies worldwide.



Flowserve Corporation
5215 North O'Connor Blvd.
Suite 2300
Irving, Texas 75039-5421 USA
Telephone: +1 937 890 5839

PS-10-31g (E) May 2018

Flowserve Corporation has established industry leadership in the design and manufacture of its products. When properly selected, this Flowserve product is designed to perform its intended function safely during its useful life. However, the purchaser or user of Flowserve products should be aware that Flowserve products might be used in numerous applications under a wide variety of industrial service conditions. Although Flowserve can provide general guidelines, it cannot provide specific data and warnings for all possible applications. The purchaser/user must therefore assume the ultimate responsibility for the proper sizing and selection, installation, operation, and maintenance of Flowserve products. The purchaser/user should read and understand the Installation Instructions included with the product, and train its employees and contractors in the safe use of Flowserve products in connection with the specific application.

While the information and specifications contained in this literature are believed to be accurate, they are supplied for informative purposes only and should not be considered certified or as a guarantee of satisfactory results by reliance thereon. Nothing contained herein is to be construed as a warranty or guarantee, express or implied, regarding any matter with respect to this product. Because Flowserve is continually improving and upgrading its product design, the specifications, dimensions and information contained herein are subject to change without notice. Should any question arise concerning these provisions, the purchaser/user should contact Flowserve Corporation at any one of its worldwide operations or offices.

©2018 Flowserve Corporation. All rights reserved. This document contains registered and unregistered trademarks of Flowserve Corporation. Other company, product, or service names may be trademarks or service marks of their respective companies.