



Progressive Cavity Pump

Applications

FOOD & BEVERAGE



DAIRY
Milk, Cottage cheese, Cream, Peanut butter, Yogurt, Coffee whitener, Ice cream, Custard



CONFECTIONERY
Chocolate, Cocoa butter, Liquor, Caramel, Liquorice, Marzipan, Nougat



FRUIT AND VEGETABLES
Potatoes, Mashed potatoes, Fruit purée



SAUCES AND PRESERVES
Mayonnaise, Ketchup, Apple sauce, Honey, Jam, Golden syrup, Horseradish, Mustard, Salad cream



SUGAR AND STARCH MOLASSES
Glucose syrup, Corn starch, Sugar starch



MEAT, FISH, AND POULTRY
Sausage meat, Pork fat slurry, Animal fat, Pet food, Fish



FATS AND OILS
Cod oil, Corn oil, Lard, Linseed oil, Peanut oil, Vegetable oil, Rape-seed, Coconut oil, Soy bean oil

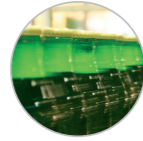

BEER AND WINE
Beer, Brewers yeast, Wine, Lees, Must



BAKERY
Batter, Butter, Egg, Dough, Glazes, Frosting, Yeast Slurry, Cake mix



BEVERAGES
Fruit concentrate

BEAUTY & PERSONAL CARE



Shampoo, Shower gels, Suncream, Perfume/cologne, Toothpaste, Mouthwash, Face wash, Face scrubs, Mousse, Make up, Hair gels, Bath bombs ingredients, Creams, Lotions, Moisturisers

fluidity.nonstop

fluidity.nonstop® is about keeping your processes running. And it's our promise and our commitment to a level of service and a quality of product, performance and expertise that has never been bettered.

By its nature, *fluidity.nonstop* is never static, that promise is ever-evolving and improving. As needs and demands change, we work to meet those new challenges and try to surpass them. We are Europe's leading source of pumps and pump expertise for the process industry and we intend to maintain that position by working fluidly and ceaselessly to be the best.

For more information, please visit www.axflow.com



AxFlow Group Headquarters
Sweden +46 8 54 54 76 70
www.axflow.com

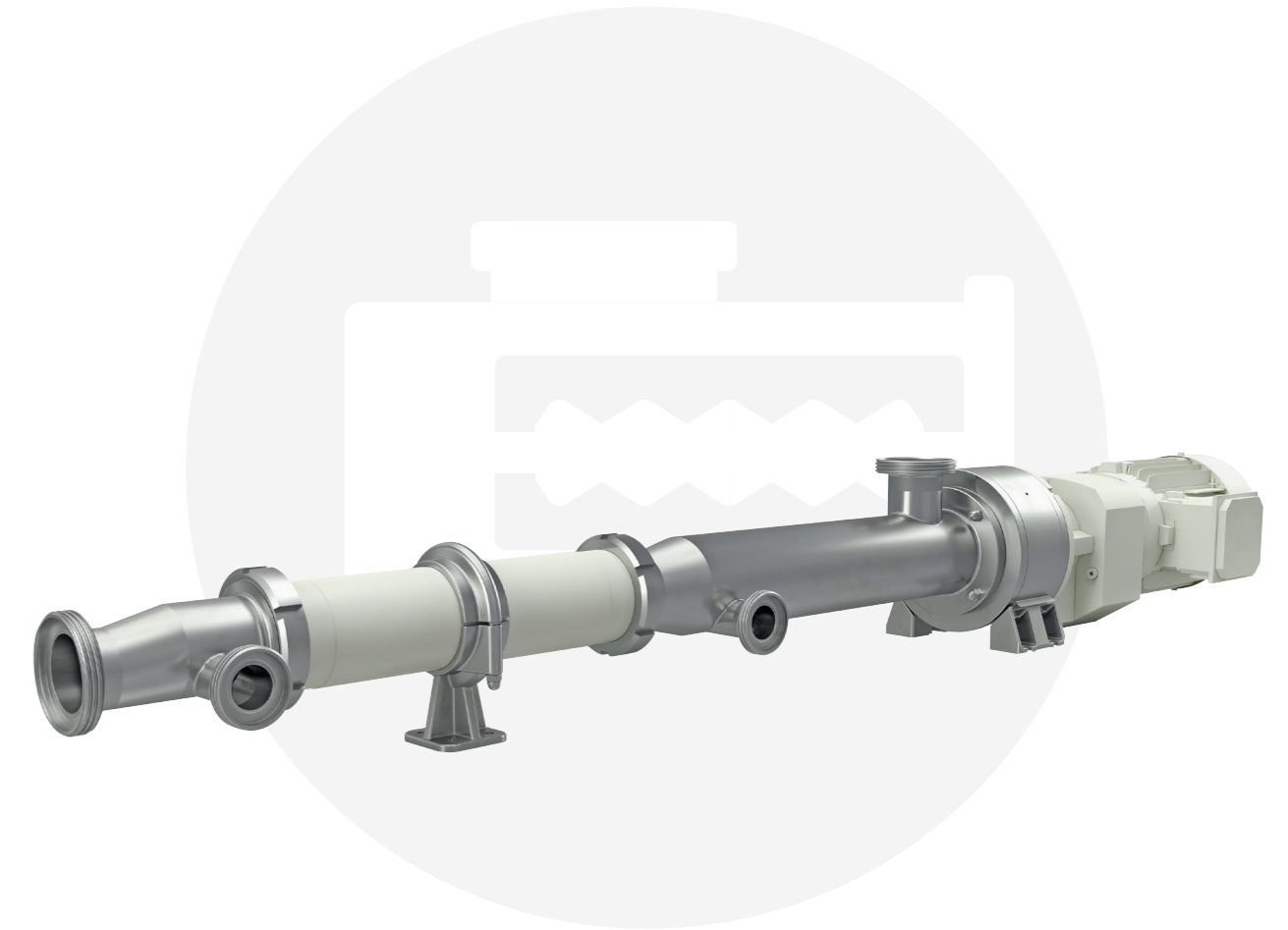

NOV Mono Hygienic Pump Range



AHQ/5/ENG/0749/2019 © fluidity.nonstop is a registered trademark of the AxFlow Group



Progressive Cavity Pump

NOV Mono Hygienic PC pump

Reliable & well-proven design for hygienic applications

✓ Robust and well-proven product design allowing a wide selection of hygienic applications

- Suitable for thin, corrosive and abrasive liquids.
- Gentle handling of shear-sensitive liquids.
- Pumps suspended solids with minimal damage to product.
- Entrained air and gases in applications like yeast and nougat.
- Ideal for accurate batching processes.

✓ Quick disassembly design for easy cleaning (out of place if required) and on-site maintenance.

- Non-pulsating, metered flow and allows variable speed control.
- Abrasion-resistant and FDA-compliant elastomers for all stators.
- Allows viscous slurries (even over 1 000 000 cps).
- Transfers solids up to 25 mm in diameter.
- Maximum differential pressure of 12 bar.
- Various drive options are available and 316 stainless-steel drive covers can be provided.
- CIP ports to any pump and positioned to suit your process.

- The mechanical seal is located under the inlet and suction area for optimized cleaning.
- Detachable titanium flexishaft.
- Tiebar-free design to aid with strip down and maintenance.
- No valves to clog, stick, or vapor lock.

✓ Reduced cost of ownership over the pump's life

- Possibility to replace the rotor and flexishaft independently when required.

✓ Fast up and running



- Parts on stock at AxFlow Distribution Center.
- Fast and professionally performed installation of pumps by AxFlow Service.

✓ Fit in complete system or on trolley



- Long engineering experience from skid-based solutions right up to highly complex, critical and ground-breaking systems.



Pump on a trolley by AxFlow Systems

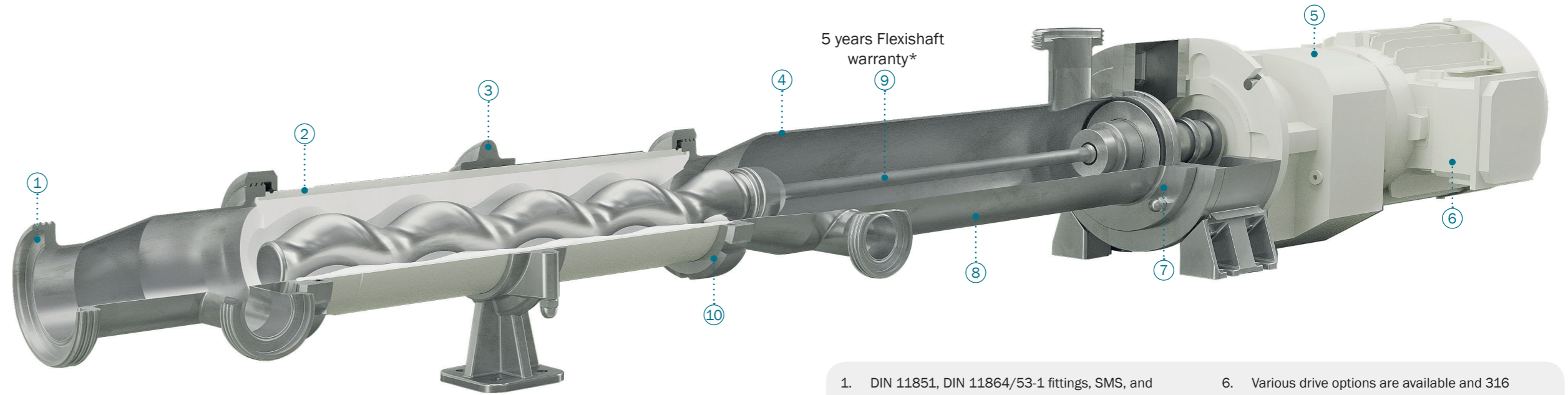

5 years Flexishaft warranty*



IT'S NOT ABOUT SIZE. IT'S ABOUT THE PERSPECTIVE.

Technologically advanced production requires technologically advanced solutions where fluid handling equipment is an integral part of a system. We have over 40 years of engineering experience from skid-based solutions right up to highly complex, critical and ground-breaking systems, in all market segments.



A "ONE-STOP-SHOP"

AxFlow has been supplying pumps to the hygienic sector for several decades. We understand the pros and cons of the various pump types, valves, mixers, heat exchangers etc. We like to think we have the technically correct and most cost effective answer for every application.



AXFLOW SERVICE – IS ABOUT KEEPING YOUR PROCESSES RUNNING

Quality, fast and professionally performed installation of pumps, design and assembly of pumping systems and their subsequent service according to current customer needs and requirements are the basis of efficiently and reliably operating technologies and production lines.



HOW SOON CAN I GET MY PARTS?

From our Distribution Centre we can deliver products and parts on stock within 48 hours to most places in Europe. **Our NOV Mono stock always concern +100 pumps including models with capacities from 50 l/hr to 80 m³/hr and with a pressure of up to 12 bar.**

1. DIN 11851, DIN 11864/53-1 fittings, SMS, and Tri-Clamp hygienic connections are available on all sizes and are eccentric to ensure self-draining.
2. Abrasion-resistant and FDA-compliant elastomers for all stators.
3. Mounted and locked in place by a stainless-steel foot.
4. CIP ports can be added to any pump and positioned to suit your process.
5. The pump is mounted from the geared motor with superior paint for protection from spray down and available with covers if required.

6. Various drive options are available and 316 stainless-steel drive covers can be provided.
7. The mechanical seal is located under the inlet and suction area for optimized cleaning.
8. One piece suction chamber made from 316 stainless-steel with a finish of 0.8 µm Ra or better.
9. Proven flexishaft technology made from titanium to keep footprint to a minimum.
10. Tiebar-free design to aid with strip down and maintenance.

*As the original innovator in flexishaft technology NOV Mono can warrant this design and component for 5 years. The flexishaft eliminates wearing components between the drive end and the pumping element. No lubrication is needed, therefore product contamination is eliminated.

Pre-selection Tables

	Model size	Single Stage
92 (406)	F178K	
66 (290)	F165K	
30 (132)	F150K	
11.4 (50,1)	F137K	
6,21 (27,3)	F130K	
2,87 (12,6)	F123K	
1,11 (4,87)	F117K	
		0 6 (87)

Capacity m³/hr (USGPM)
Differential pressure Bar (PSI)

	Model size	Double Stage
46 (203)	F178B	
33 (145)	F165B	
15 (66)	F150B	
5,7 (25,1)	F137B	
3,1 (13,7)	F130B	
1,44(6,3)	F123B	
0,55 (2,44)	F117B	
		0 12 (174)

Capacity m³/hr (USGPM)
Differential pressure Bar (PSI)