

Absolute "ZERO" Leakage



OmniSeal[®] Double Block & Bleed Expanding Plug Valve

High integrity double block and bleed expanding plug valves for product isolation, blending, metering, custody transfer, fueling operations, terminal, storage and other land or offshore zero leakage applications.

- API 6D Monogrammed
- Highest Quality Plug Valves at Affordable Prices
- Delivered to Exact Customer Specifications and Requirements
- Engineered, Assembled and Tested for Years of Trouble Free Service

Global Energy Market Solutions

OmniSeal® DB&B expanding plug valves are ideally suited for product isolation, refining, fueling, metering, terminal and storage applications.



OmniSeal® expanding plug valves are designed for applications where positive shut-off, verifiable zero leakage and double block and bleed (DB&B) and or double isolation and bleed (DIB) capabilities are required.

They are ideal for a variety of applications including leased automated custody transfer (LACT), product metering, aviation fueling, product isolation, blending, lockout/tagout (LOTO), multi-product manifolds, tank storage and other DB&B applications.

The OmniSeal® is a single valve solution that simultaneously blocks both the upstream and downstream flow while allowing the user to verify seal integrity using a manual or automatic body bleed system. It replaces older double block and bleed systems that use two valves with a spool and bleed valve in-between. OmniSeal® valves have exclusive features designed for better performance throughout the valve's lifetime.

All OmniSeal® DB&B expanding plug valves are manufactured and monogrammed per API 6D and ISO 9001, fire tested per API 607 and API 6FA and have specific certifications such as CE/PED, CRN (Canadian Registration), TA-Luft or similar design or regional certifications where appropriate.

OmniSeal® DB&B expanding plug valves have been determined to be a "Product of the USA" by the US Customs and Border Protection Agency (CBP). This applies to both commercial and US government or military procurement.

Table of Contents

Introduction	3
Applications	4
Single Valve DB&B Solutions	5
Typical Valve Configuration	6
Size Range & Materials of Construction	7
Valve Operations	8
Design Features	10
Relief Systems	12
Dimensions - Reduced Port / HW Operated / Class 150-300-600	14
Dimensions - Reduced Port / Gear Operated / Class 150	15
Dimensions - Reduced Port / Gear Operated / Class 300	16
Dimensions - Reduced Port / Gear Operated / Class 600	17
Dimensions - Reduced Port / Gear Operated / Class 900	18
Torque & Turns Charts / Automation	19
Motor Adaptation Kits	20
Operator Orientation Options	21
Limit Switch Assemblies	22
Position Indicators and Locking Mechanisms	23
Stem Extensions	24
Replacement Parts and Rebuild Kits	25
Figure Numbers	26
Manufacturing and Trademarks	27



OmniSeal[®] expanding plug valves are ideal for applications that require positive shut-off, verifiable zero leakage and double block and bleed (DB&B) and or double isolation and bleed (DIB) capability. Some of the more common applications include:

Blending Units: Accurate blending of ethanol or other regional fuel grades requires valves with exceptionally high seal integrity to ensure accurate measurement of additives and blending stocks. The OmniSeal[®] DB&B is specifically designed for these type of applications.

Product Isolation: Secure isolation of biofuels or other process-sensitive fluids is critical for environmental and process safety. The OmniSeal[®] DB&B's verifiable zero leakage and positive shutoff capabilities make it an ideal solution for isolation and process-sensitive applications.

Multi-Product Manifolds: Pipeline, refinery and transfer manifolds need to flow multiple products (e.g. diesel, jet fuel, gasoline, blending stocks, etc) reliably and without contamination. The OmniSeal[®] DB&B is an effective tool for preventing product cross-contamination.

Prover Loops: Proper calibration of flow meters requires that every valve in the prover loop system must have a zero leak rate. Any leak could mean an error in calibration. OmniSeal[®] DB&B valves are used to ensure leak tight closure and accurate calibration.

Custody Transfer Units: Transfer of valuable media relies on accurate measurement of product transfer quantity. The OmniSeal[®] DB&B provides positive shutoff and zero leak rate, thereby ensuring the accuracy of transfer quantity calculations.

Offshore Platforms: Valve leakage on an offshore platform can result in damage to equipment and the environment. The OmniSeal[®] DB&B has excellent low pressure positive shutoff characteristics and is a great choice for use on offshore platforms.

Terminals: Terminals used for loading and unloading tankers require valves with positive sealing in order to prevent environmental damage due to spillage. The OmniSeal[®] DB&B provides positive sealing and zero leak rate in a reliable single valve solution.

Tank Farms (Oil Depots): Tank isolation valves, which are operated frequently, require zero leak rate and a high degree of reliability. The OmniSeal[®] DB&B valve provides a reliable, high integrity seal designed for frequent and long-term use.

Aviation Fueling Systems: Airport fueling systems require valves that close quickly and have verifiable seal integrity. This allows for quick maintenance, repair, leak location and testing. The OmniSeal[®] DB&B valve's verifiable zero leak rate ensures that maintenance, repair, leak location and hydrant testing can be done safely and quickly. OmniSeal[®] DB&B expanding plug valves have been determined to be a **"Product of the USA"** by the US Customs and Border Protection Agency (CBP). This applies to both commercial and US government or military procurement.



The OmniSeal® replaces antiquated two-valve systems with a single DB&B valve solution. The OmniSeal® has two seats (slips) and provides a bubble tight seal.

Older double block & bleed systems use two valves and a spool with a bleed valve used to drain and verify seal integrity.

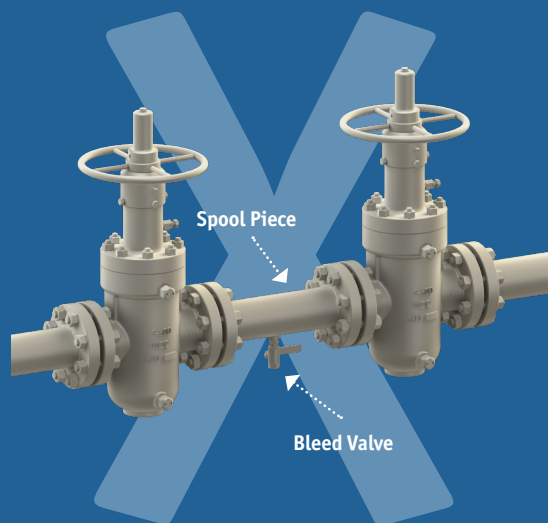

Solution... The OmniSeal® Plug Valve



1. The OmniSeal® upstream and downstream slip seals provide the same function as the two block valves shown above.



2. The OmniSeal® body (serving as the spool piece shown top left) bleeds to verify seal integrity.

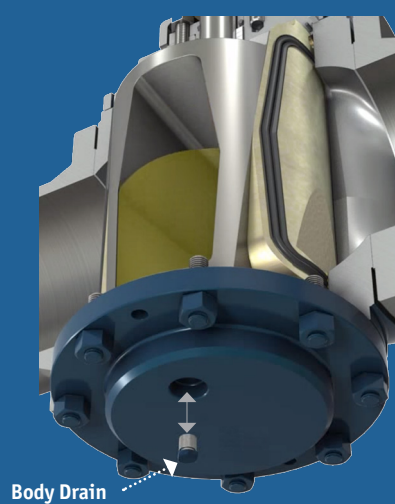



Gear Operated Valve

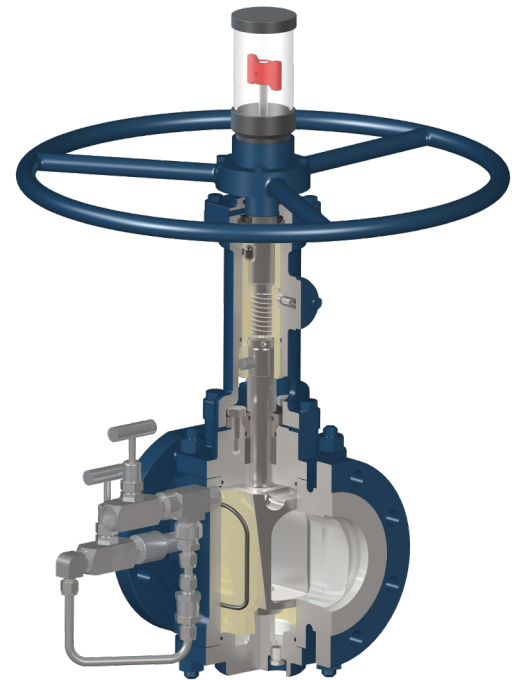
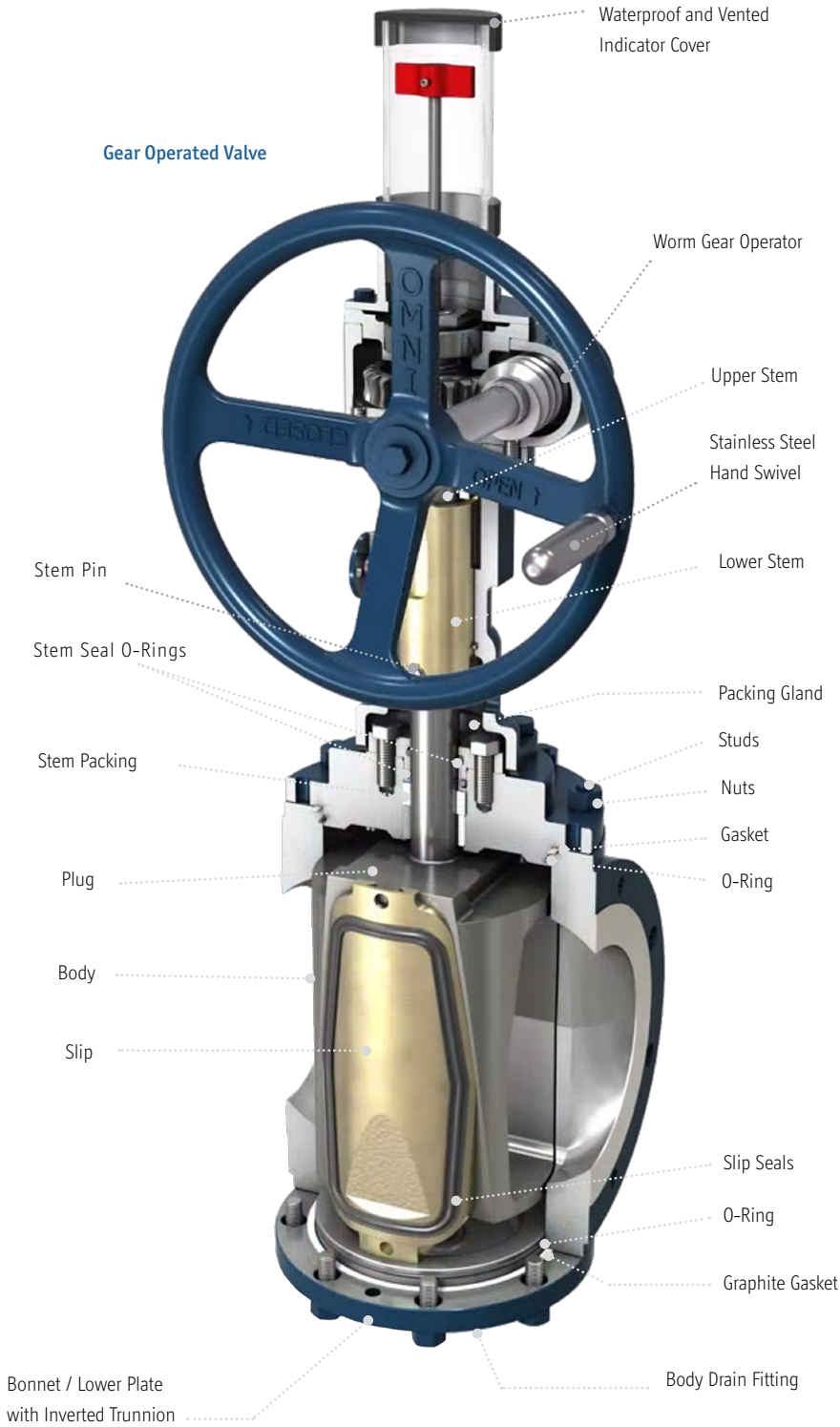

Handwheel Operated Valve

Size Range & Materials of Construction



Available Sizes and Pressures

ANSI Class	Sizes (inches)														
	2	3	4	6	8	10	12	14	16	18	20	24	28	30	36
150	HW/GO	HW/GO	HW/GO	HW/GO	GO*	GO*	GO*	GO*	GO*	GO*	GO*	GO*	GO*	GO*	GO*
300	HW/GO	HW/GO	HW/GO	GO*	GO*	GO*	GO*	GO*	GO*	GO*	GO*	GO*	GO*	GO*	N/A
600	HW/GO	HW/GO	GO	GO*	GO*	GO*	GO*	GO*	GO*	GO*	GO*	GO*	GO*	N/A	N/A
900	N/A	GO*	GO*	GO*	GO*	N/A	N/A	GO*	GO*	N/A	N/A	N/A	N/A	N/A	N/A

HW = Available Only as Handwheel Operated

GO = Available Only as Gear Operated

HW/GO = Available as Handwheel or Gear Operated

* These sizes have lifting lugs

Standard Materials of Construction (Alternative materials available upon customer request)

All OmniSeal® plug valves are constructed to meet requirements of NACE MR0175 / ISO 15156

Component	Standard Temp. (-20° to 400° F) (-29° to 204° C)	Low Temp. (-49° to 400° F) (-45° to 204° C) (1)
Body	Cast ASTM A216 WCC (2)	Cast ASTM A352 LCC (2)
Bonnet/ Lower Plate	Cast ASTM A216 WCC / Forged ASTM A350 LF6 CL2	Cast ASTM A352 LCC / Forged ASTM A350 LF6 CL2
Plug and Stem	Cast ASTM A216 WCC (3)	Cast ASTM A352 LCC (3)
Slips	Cast Ductile Iron / Cast A395 GR 60-40-18	Cast ASTM A352 LCC
Packing Gland	Forged ASTM A350 Gr. LF2	Forged ASTM A350 Gr. LF2
Stem Packing	Pre-Formed Flexible Graphite	Pre-Formed Flexible Graphite
Gasket	Pre-Formed Flexible Graphite	Pre-Formed Flexible Graphite
O-Rings & Slip Seals	Viton B (4)	Viton GFLT (4)
Bonnet to Body Studs	ASTM A193 Gr. B7M	ASTM A320 Gr. L7M
Bonnet Nuts	ASTM A194 Gr. 2HM	ASTM A194 Gr. 2HM
Relief System Tubing	AISI 316 SS / AISI 304 SS	AISI 316 SS / AISI 304 SS
Relief System Needle Valve	AISI 316 SS	AISI 316 SS
Relief System Check Valve	AISI 316 SS	AISI 316 SS

Notes: (1) -49°F is the minimum temperature rating using our standard materials of construction however lower temperature ratings are available to meet customer requirements.

(2) Electroless Nickel Plated - Entire Internal Surface

(3) Electroless Nickel Plated - Entire Component

(4) All OmniSeal® valves in class 300 & 600 are supplied with double reinforced Viton seals.

Optional Materials of Construction & Other Customized Features

OmniSeal® DB&B Expanding Plug Valves are available in a variety of configurations and material of construction depending on customer preferences, specifications, severe temp ranges and / or service conditions.

Common valve options include:

- Flanges drilled to DIN or other regional standards, or constructed with face to face dimensions specific to particular projects
- Subjected to more rigorous customer-specified extended testing regimes
- Special coating applications based on customer specifications, service conditions or cosmetic preferences
- Constructed to withstand extreme high or low temperatures - Please consult factory
- Customer specified limit switches or other accessories
- Special Automatic Body Bleed Valve (ABBV) or customer specific relief systems



Fully Open Position

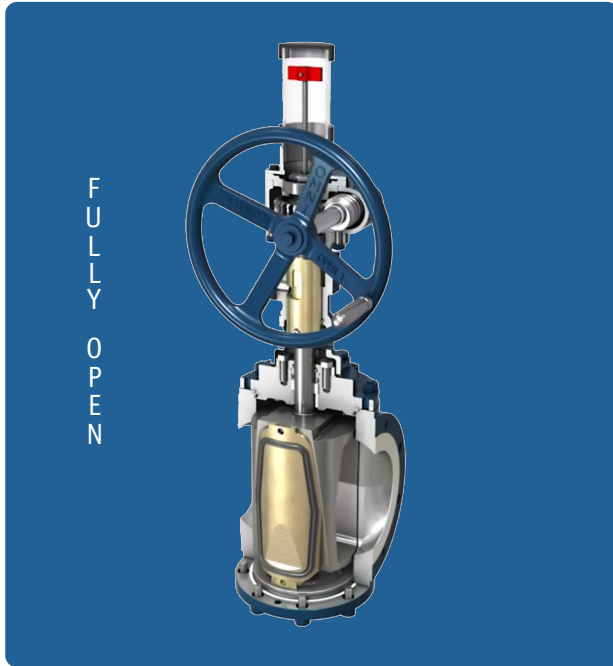

In the fully open position, the resilient seals are positioned out of the flow path and protected within the body of the valve itself.

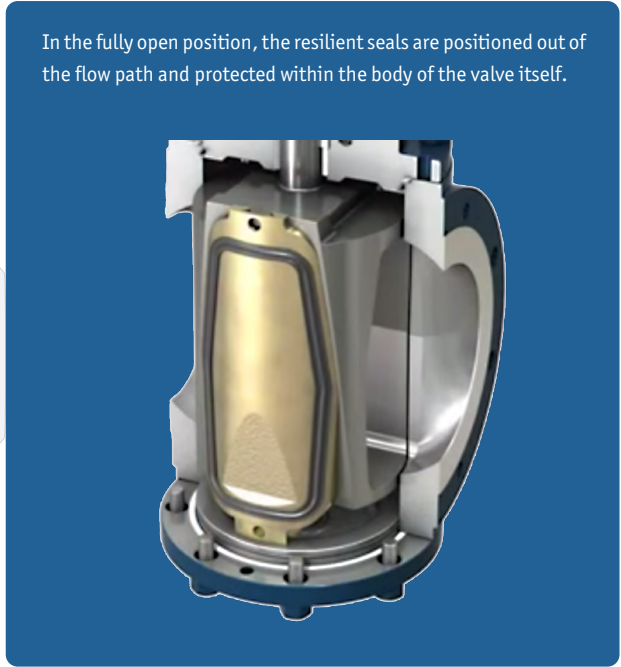

Partially Closed Position

As the valve is cycled from the fully open to closed position, the plug begins a 90 degree rotation.



During the entire rotation of the plug the resilient seals located on both slips are retracted away from the body. This ensures no rubbing or scraping action during rotation of the plug from the open to the closed position.



Closed Position Prior to Sealing

After the plug has been rotated 90 degrees from the fully open to fully closed position, the resilient seals on both slips have not yet been forced outward and into the seating position. This expansion only occurs with continued rotation of the handwheel or actuator.

B
E
F
O
R
E

C
L
O
S
I
N
G



With continued rotation of the handwheel, this small gap between the slip seal and the valve body is closed by the slip moving in the outward direction. Once the slip seal is firmly seated against the valve body sealing surface, the valve achieves a positive, zero-leakage seal.



Fully Closed (Sealed) Position

F
U
L
L
Y

C
L
O
S
E
D

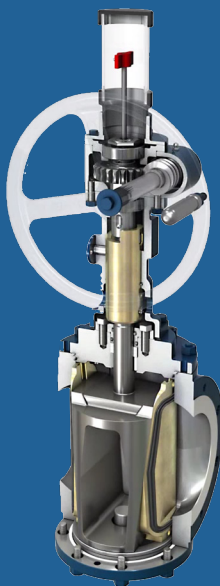

To fully close the valve and provide positive shut-off, the slips are expanded outward with continued rotation of the handwheel or actuator. This outward expansion is achieved by the tapered plug moving downward which causes the slip seals to seal against the valve body.



Positive, **Zero-Leakage** Seal

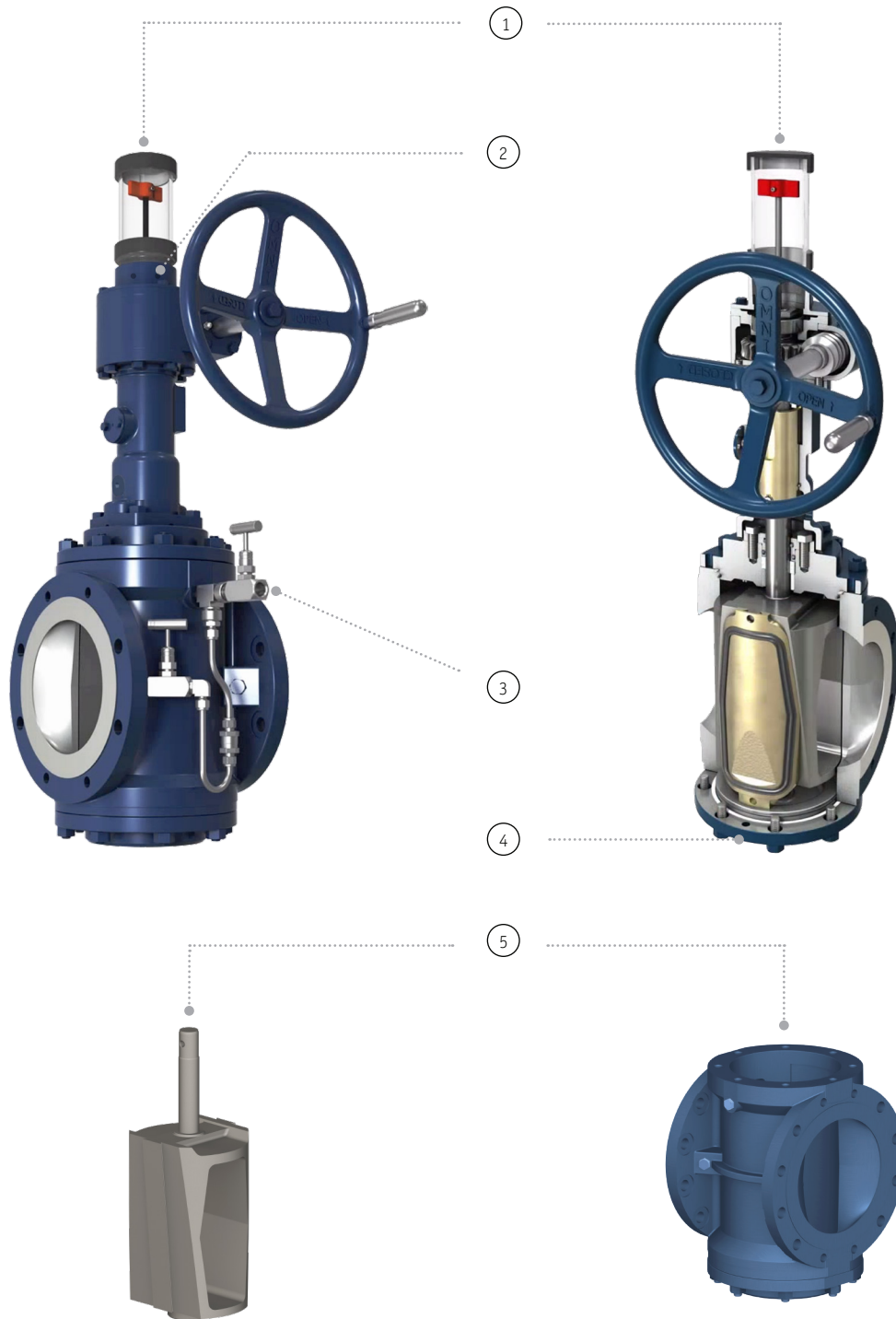

Call out information on corresponding page

OmniSeal® DB&B Expanding Plug Valve Exclusive Design Features

1. Polycarbonate Protector Cap

The OmniSeal® DB&B expanding plug valve has a robust polycarbonate indicator flag protector. This keeps moisture and debris from infiltrating the operator housing. The top of the indicator cap (shown below) is vented to ensure that air flow will quickly evaporate any condensation that appears inside the clear housing.

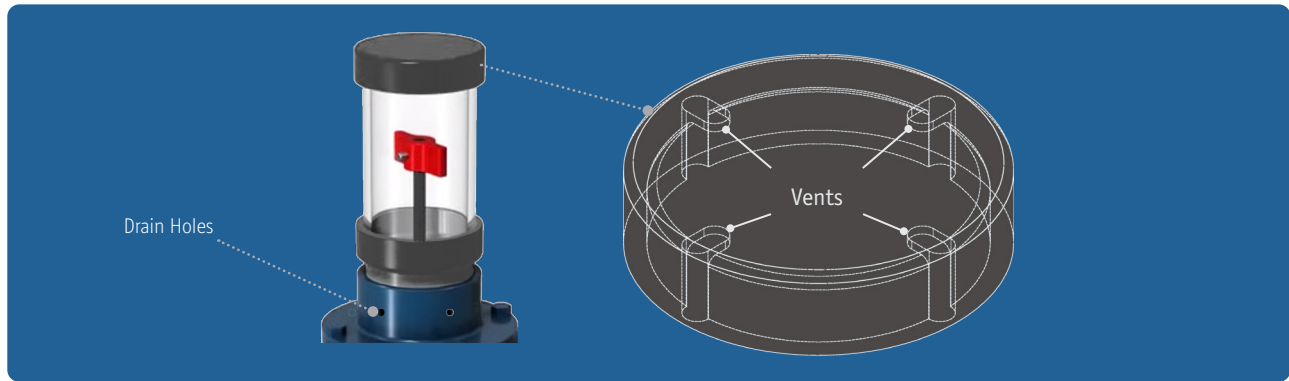

2. Drain Holes

The upper adapter is blanked off underneath the protector cap. It features one penetration sealed with an o-ring for the indicator shaft. This prevents moisture ingress into the gearbox in the event that the indicator protector is removed or damaged. Drain holes in the adapter allow evacuation of any moisture/ condensation that may be in the area.

3. Location of Relief System Port

Some competitive DB&B plug valve offerings have the top port for the relief system located on the upper bonnet. Therefore, the relief system must be disconnected whenever the upper bonnet needs to be removed for maintenance or repair. The OmniSeal® port is located on the upper section of the valve body. This eliminates any need to disassemble the relief system in order to remove the valve bonnet.

4. Lower Trunnion Design

The lower trunnion of the OmniSeal® valve is an integral part of the lower bonnet and is **NOT** part of the plug. There is no cavity present in the bottom of the valve body to collect dirt, scale, ice or other debris that could make the valve hard to turn or otherwise interfere with valve function.

5. Surface Treatment of Body Cavity and Plug

The interior cavity of the valve body and the entire plug are plated with electroless nickel to ensure a corrosion-free sealing surface for slip seals.

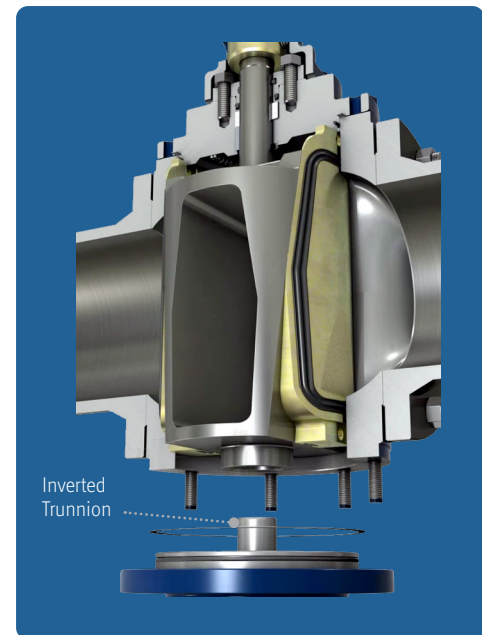



Excess pressure is normally the result of thermal expansion of the fluid and gases trapped inside the valve body. The trapped media is relieved to the upstream side when the pressure inside the valve body is 25 psi (in a standard check valve) greater than the pressure in the upstream piping. The 25 psi spring can be changed in the check valve. Available pressures range from 1 psi to 100 psi.

OmniSeal® valves have a 100% zero verifiable leakage guarantee. This means that any leaks that get past the upstream slip seal will be indicated through the bleed to atmosphere valve before they are able to leak past the downstream slip seal. This prevents any costly contamination to other products caused by undetected leakage.

In order for the automatic relief system to function properly, the valve that controls the upstream relief must be kept open and the valve that controls the manual bleed to atmosphere must be kept closed. Unless otherwise specified by the customer all systems include an upstream isolation valve to allow servicing of the DTR without draining the upstream line. This isolation valve also aides in troubleshooting the plug valve and its relief system.



Manual Bleed with Thermal relief to Upstream - (Standard)

The standard relief system offered on the OmniSeal® valve is designed to relieve excess pressure in the valve cavity due to thermal expansion when the valve is in the closed position. The system also features a manual bleed to atmosphere.

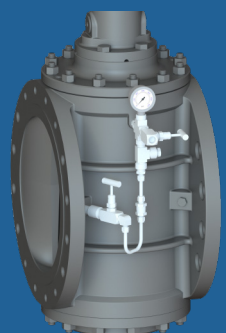

Manual Bleed with Thermal Relief to Upstream - With Gauge

This system functions the same as the standard system with the addition of a pressure gauge piped into the body cavity. This allows a visual indication of pressure present in the valve body without exposing the body cavity to the atmosphere. The figure also shows an additional plugged NPT port as specified by the customer. The additional port can be added to any DTR configuration as requested by the customer.



Cold Climate

This configuration is similar to the standard DTR configuration. The only difference is that the piping and check valve are in an orientation that prevents fluids from settling in the piping. This is done to prevent moisture from accumulating in the DTR system and freezing which would cause damage to the system. The orientation shown is the most effective method when the valve is installed in the upright position. The customer must specify in which orientation the valve will be installed so that the piping can be configured to function properly.



Manual Relief to Atmosphere, Thermal Relief from Downstream and Body to Upstream

This configuration contains automatic bleed to upstream with a manual bleed to atmosphere. In addition to the body bleed to upstream there is an automatic bleed from the downstream side of valve to the upstream side of valve. This keeps the pressure created by thermal expansion in the downstream piping to a minimum. There are isolation valves on the upstream side and the downstream side of the valve to enable servicing of the DTR system without removing the entire valve from service.



Upstream Vent Full Isolation

This ADTR system contains automatic bleed to upstream with a manual bleed to atmosphere. There is an isolation valve on the upstream side of the valve as well as on the body side of the valve to enable servicing of the ADTR system without removing the entire valve from service. Additionally there is a bleed to atmosphere located on the upstream side of the valve that allows the operator to vent the pressure from the upstream side of the valve without opening the valve.



Customer-Specified Relief Systems

All ADTR systems can be configured with customer specified components and designs. The one shown in the figure is built using locking ball valves, however any valve design and manufacture can be used including, but not limited to, ball valves, needle valves, and gate valves. [Please contact Omni Valve for more details.](#)

Dimensions



Reduced Port / HW Operated / Class 150-300-600

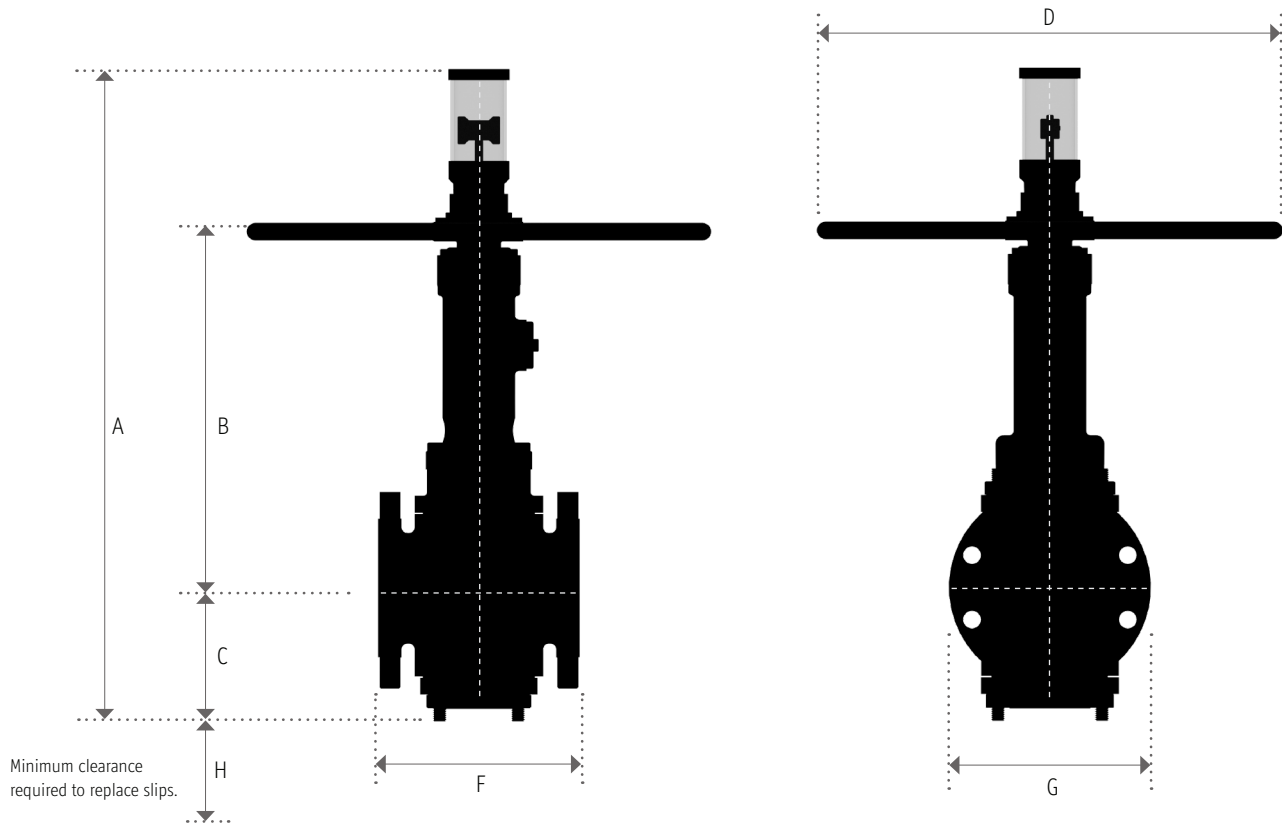

Class	Size	Oper.	A		B		C		D		F		G		H		Weight		(Number) & Size Tapped Holes Each Flange
			in.	mm	in.	mm	in.	mm	in.	mm	in.	mm	in.	mm	in.	mm	lbs	kgs	
150	2	37H	18.0	457	10.6	269	4.0	102	10	254	7	178	6	152	3	76	55	25	none
	3	37H	18.0	457	10.6	269	4.0	102	10	254	8	203	7.5	191	3	76	68	31	none
	4	50H	27.5	699	16.0	406	6.0	152	20	508	9	229	9	229	4.5	114	142	64	none
	6	50H	32.6	828	18.0	457	7.5	191	20	508	10.5	267	11	279	8	203	224	102	(4) 3/4"-10 UNC
300	2	37H	18.0	457	10.6	269	4.0	102	10	254	8.5	216	6.5	165	3	76	60	27	none
	3	37H	18.0	457	10.6	269	4.0	102	10	254	11.1	282	8.25	210	3	76	62	28	none
	4	50H	28.3	719	16.0	406	5.5	140	20	508	12	305	10	254	5	127	166	75	none
600	2	50H	26.0	660	15.5	394	4.0	102	20	508	11.5	292	6.5	165	2.5	64	113	51	none
	3	50H	26.0	660	16.0	406	5.0	127	20	508	14	356	8.3	211	3.5	89	120	54	none

* Contact factory for CV data

Dimensions



Reduced Port / Gear Operated / Class 150

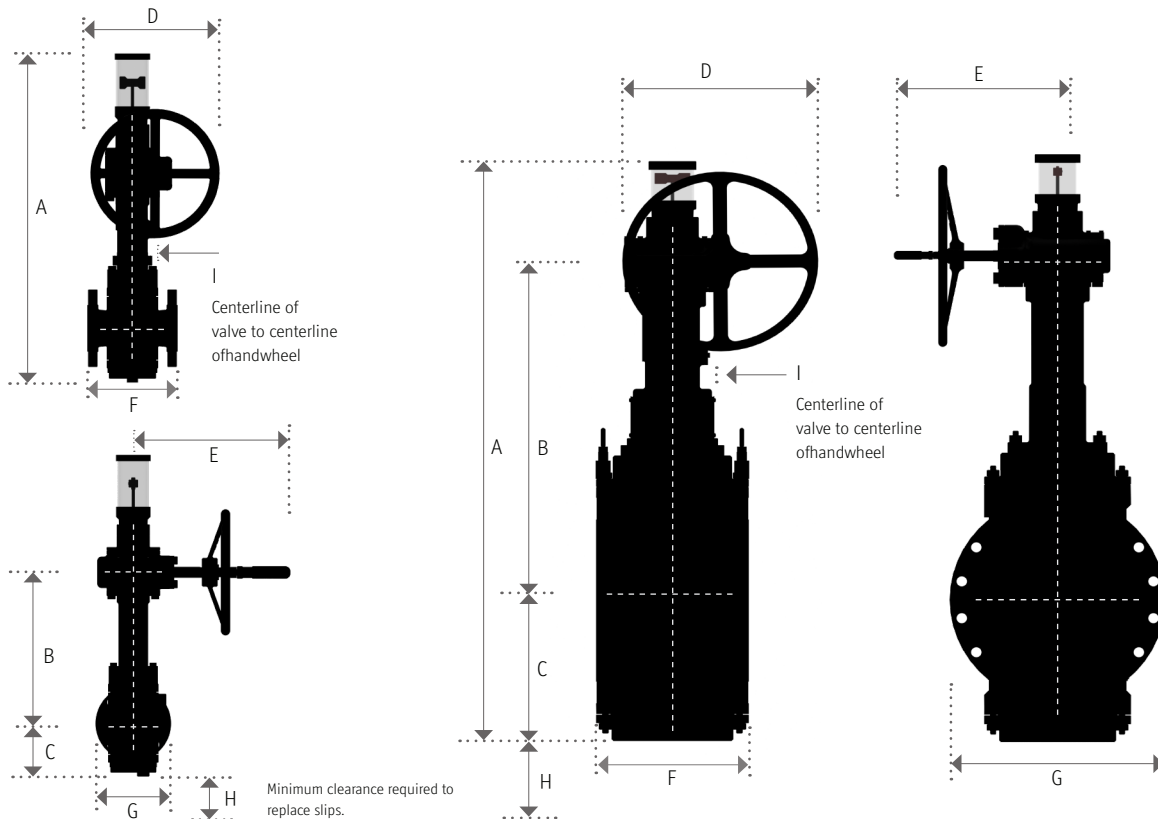

Class	Size	Oper.	A		B		C		D		E		F		G		H		I		Weight		(Number) & Size Tapped Holes Each Flange
			in.	mm	in.	mm	in.	mm	in.	mm	in.	mm	in.	mm	in.	mm	in.	mm	in.	mm	lbs	kgs	
150	2	37G	22.8	579	11.9	302	4.0	102	10	254	12.4	315	7	178	6	152	3	76	1.8	44	78	35	none
	3	37G	22.8	579	11.9	302	4.0	102	10	254	12.4	315	8	203	7.5	191	3	76	1.8	44	93	42	none
	4	55G	30.0	762	16.1	409	6.0	152	10	254	14.7	373	9	229	9	229	4.5	114	2.4	61	168	76	none
150	6	55G	34.6	879	18.3	465	7.5	191	10	254	14.4	366	10.5	267	11	279	10	254	2.4	61	249	113	(4) 3/4" -10 UNC
	8	62G	42.5	1080	22.0	559	9.2	234	14	356	14.7	373	11.5	292	13.5	343	14	356	3	76	452	205	(4) 3/4" -10 UNC
	10	62G	46.0	1168	24.0	610	11.0	279	14	356	14.7	373	13	330	16	406	16	406	3	76	605	274	(4) 7/8" - 9 UNC
	12	75G	55.0	1397	31.0	787	12.5	318	20	508	14.7	373	14	356	19	483	26	660	3.5	89	858	389	(4) 7/8" - 9 UNC
	14	75G	58.0	1473	32.5	826	14.3	363	20	508	14.7	373	15	381	21	533	28	711	3.5	89	1098	498	(4) 1.0" - 8 UNC
	16V	75G	58.0	1473	32.5	826	14.3	363	20	508	14.7	373	16	406	23.5	597	28	711	3.5	89	1150	522	(8) 1.0" - 8 UNC
	18V	12G	64.9	1648	38.7	983	16.0	406	20	508	17.5	445	17	432	25	635	30	762	5	127	1601	726	(8) 1 1/8" - 8 UNC
	20V	12G	69.5	1765	40.3	1024	18.6	472	20	508	17.5	445	32	813	27.5	699	32	813	5	127	3150	1429	(4) 1 1/8" - 8 UNC
	24V	12G	77.9	1979	45.6	1158	21.8	554	20	508	17.5	445	36	914	32	813	37	940	5	127	6250	2835	(8) 1 1/4" - 8 UNC
	28	14G	99.0	2515	56.7	1441	29.5	748	32	813	26	660	42	1067	36.4	925	38	965	9	229	9535	4325	(12) 1 1/4" - 8 UNC
	30	15G	97.3	2471	75.2	1910	27.4	696	32	813	26	660	60	1524	38.8	986	41	1041	9	229	16450	7462	(12) 1 1/4" - 8 UNC
	36	15G	119.2	3028	76.0	1930	30.0	762	32	813	26	660	78	1981	46	1168	41	1041	9	229	23088	10473	none

V = Designates a valve with a reduced weight design

* Contact factory for CV data

Dimensions



Reduced Port / Gear Operated / Class 300

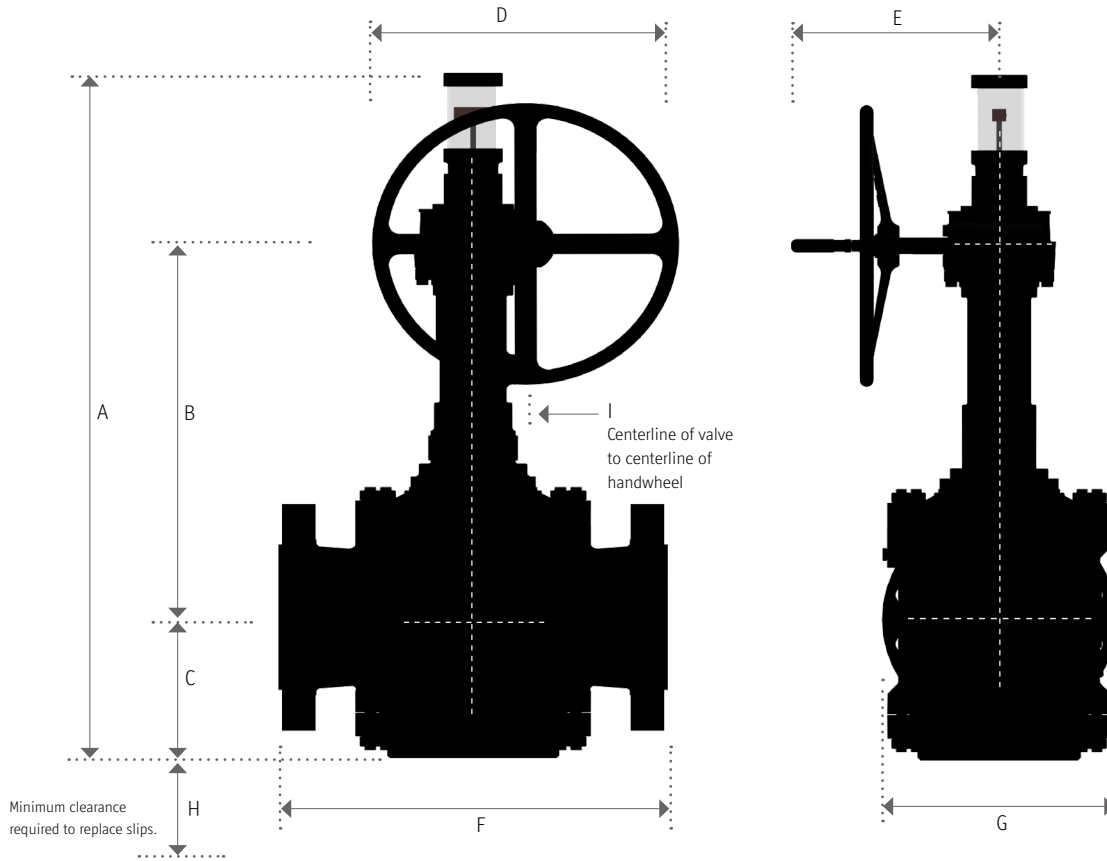

Class	Size	Oper.	A		B		C		D		E		F		G		H		I		Weight		(Number) & Size Tapped Holes Each Flange
			in.	mm	in.	mm	in.	mm	in.	mm	in.	mm	in.	mm	in.	mm	in.	mm	in.	mm	Lbs	Kgs	
300	2	37G	22.8	579	11.9	302	4.0	102	10	254	12.4	315	8.5	216	6.5	165	3	76	1.8	46	80	36	none
	3	37G	22.8	579	11.9	302	4.0	102	10	254	12.4	315	11.1	282	8.3	211	3	76	1.8	46	100	45	none
	4	55G	30.0	762	16.2	411	5.5	140	10	254	14.7	373	12	305	10	254	5	127	2.4	61	194	88	none
	6	62G	39.0	991	20.5	521	7.7	196	14	356	14.7	373	15.9	404	12.5	318	10	254	3	76	371	168	none
	8	75G	49.0	1245	28.0	711	9.5	241	20	508	14.7	373	16.5	419	15	381	14	356	3.5	89	662	300	(4) 7/8" -8 UNC
	10	75G	51.8	1316	29.0	737	11.0	279	20	508	14.7	373	18	457	17.5	445	16	406	3.5	89	889	403	(4) 1.0" -8 UNC
	12	12G	61.0	1549	36.5	927	14.0	356	20	508	17.5	445	19.8	503	20.5	521	26	660	5	127	1451	658	(8) 1-1/8" -8 UNC
	14	12G	60.9	1547	36.8	935	13.7	348	20	508	17.5	445	30	762	23	584	26	660	5	127	1644	746	none
	16	12G	60.3	1532	36.5	927	13.5	343	20	508	17.5	445	33	838	25.5	648	23	584	5	127	2777	1260	none
	18	12G	71.0	1803	40.5	1029	17.0	432	20	508	17.5	445	36	914	28	711	26	660	5	127	4704	2134	(12) 1-1/4" -8 UNC
	20	14G	81.4	2068	48.0	1219	20.0	508	32	813	26	660	39	991	30.5	775	29	737	9	229	6203	2814	(12) 1-1/4" -8 UNC
	24	14G	91.3	2319	54.1	1373	24.5	621	32	813	26	660	45	1143	36	914	38	965	9	229	8426	3822	none
30	15G	120.0	3048	71.0	1803	32.5	826	32	813	26	660	65	1651	43	1092	41	1041	9	229	21766	9873	none	

* Contact factory for CV data

Reduced Port / Gear Operated / Class 600

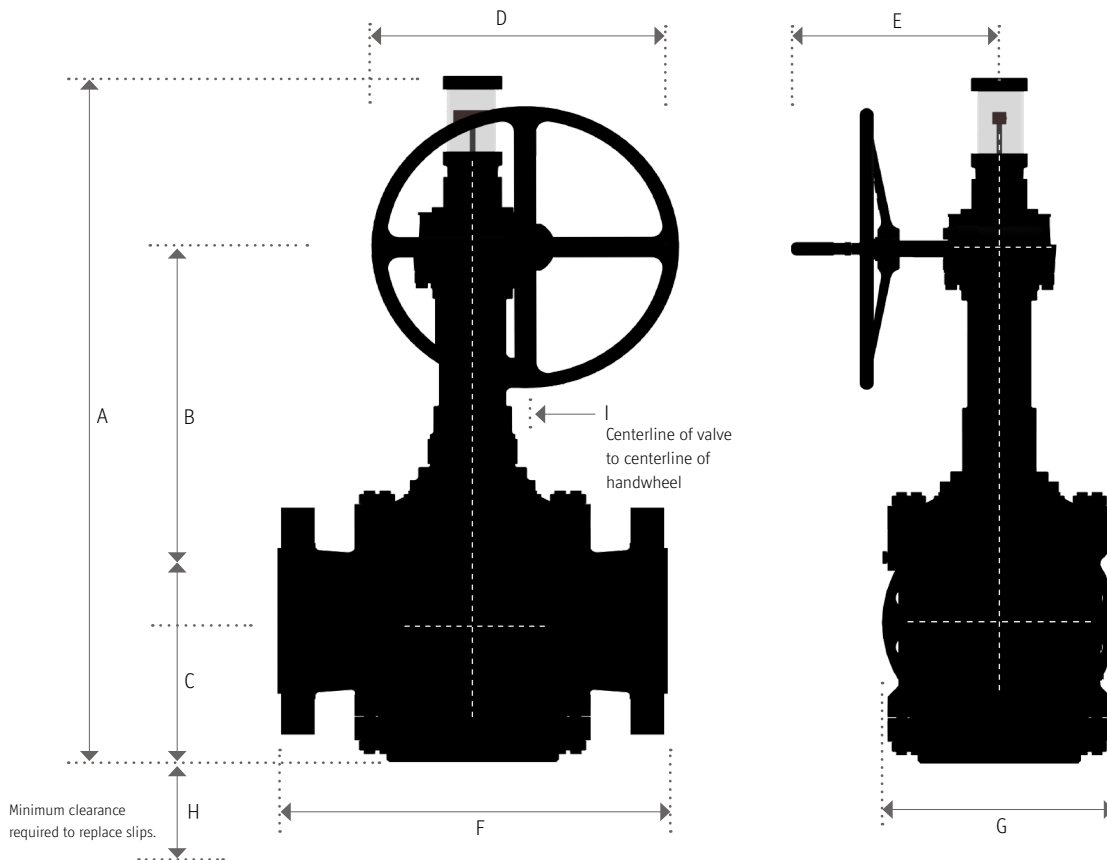

Class	Size	Oper.	A		B		C		D		E		F		G		H		I		Weight		(Number) & Size Tapped Holes Each Flange
			in.	mm	in.	mm	in.	mm	in.	mm	in.	mm	in.	mm	in.	mm	in.	mm	in.	mm	Lbs	Kgs	
600	2	55G	28.0	711	15.5	394	4.0	102	10	254	14.5	368	11.5	292	6.5	165	2.5	64	2.4	61	141	64	none
	3	55G	29.0	737	16.0	406	5.0	127	10	254	14.5	368	14	356	8.3	211	3.5	89	2.4	61	178	81	none
	4	62G	36.0	914	19.0	483	6.2	157	14	356	14.7	373	17	432	10.8	274	3.5	89	3	76	282	128	none
	6	75G	45.6	1158	26.0	660	8.0	203	20	508	14.7	373	22	559	14	356	10	254	3.5	89	704	319	none
	8	75G	48.2	1224	27.0	686	10.0	254	20	508	14.7	373	26	660	16.5	419	12	305	3.5	89	1086	493	none
	10	12G	58.4	1483	36.5	927	11.5	292	20	508	17.5	445	31	787	20	508	14	356	5	127	2027	919	none
	12	12G	61.0	1549	37.5	953	13.1	333	20	508	17.5	445	33	838	22	559	22	559	5	127	2726	1236	none
	14	14G	75.9	1928	47.0	1194	16.0	406	32	813	26	660	35	889	23.8	605	25	635	9	229	4715	2139	(4) 1-3/8"-8 UNC
	16	14G	75.7	1923	47.0	1194	15.8	401	32	813	26	660	39	991	27	686	25	635	9	229	5007	2271	(8) 1-1/2"-8 UNC
	18	14G	79.5	2019	48.8	1240	18.1	461	32	813	26	660	43	1092	29.3	743	25	635	9	229	6762	3067	(8) 1-5/8"-8 UNC
	20	15G	99.4	2525	69.5	1765	20.5	521	32	813	26	660	47	1194	32	813	25	635	9	229	10964	4973	none
24	15G	107.8	2738	71.5	1816	23.5	597	32	813	26	660	55	1397	37	940	25	635	9	229	14915	6765	(8) 1-7/8"-8 UNC	

* Contact factory for CV data

Dimensions



Reduced Port / Gear Operated / Class 900

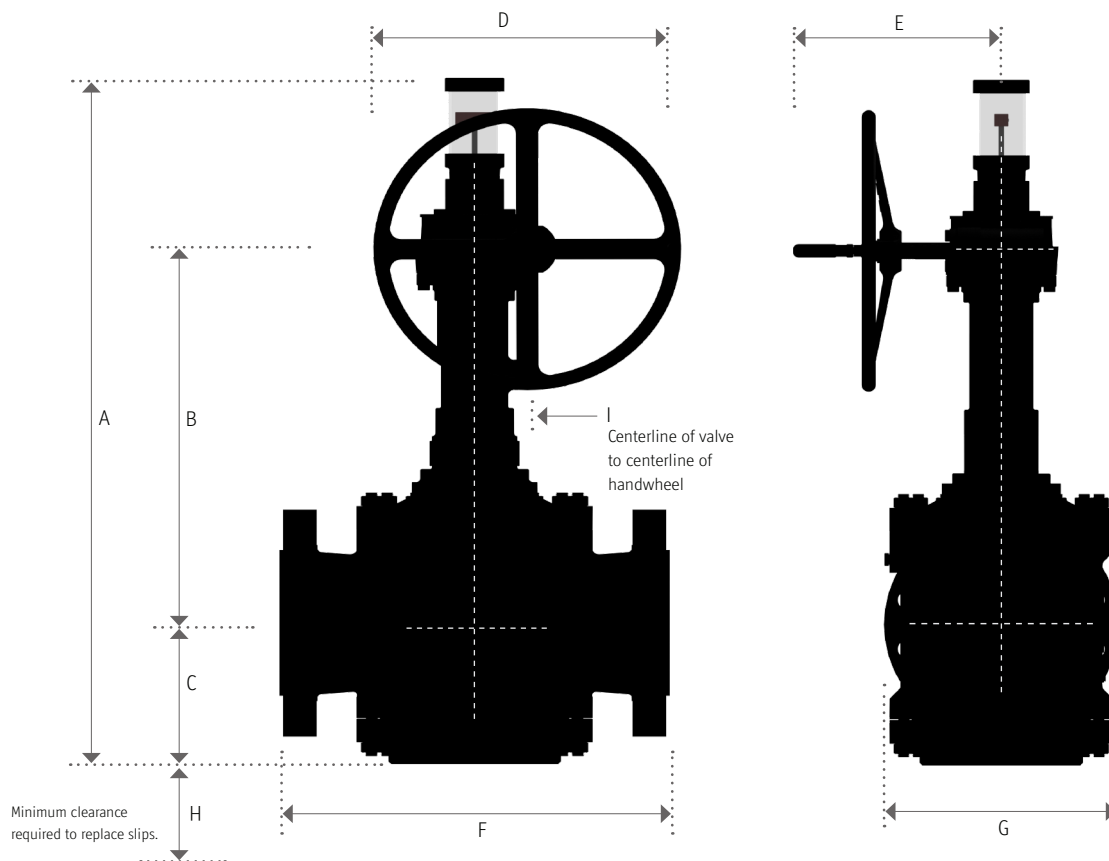

Class	Size	Oper.	A		B		C		D		E		F		G		H		I		Weight		(Number) & Size Tapped Holes Each Flange
			in.	mm	in.	mm	in.	mm	in.	mm	in.	mm	in.	mm	in.	mm	in.	mm	in.	mm	lbs	kg	
900	3	62G	35.7	907	18.4	467	5.5	139.7	14	356	14.6	371	15	381	9.8	249	5	178	3	76	308	140	none
	4	75G	46.47	1180	25.06	636	9.05	230	20	508	14.7	373	18	457.2	11.5	292.1	12	305	3.5	89	689	313	(4) 1-1/8" -8 UNC
	6	75G	47.7	1212	26.2	665	9.2	234	20	508	15.4	391	24	610	15	381	6	152	4	102	1486	674	none
	8	12G	58.31	1481	35.18	893.48	11.76	299	20	508	17.5	445	29	736.6	18.5	470	15	381	5	127	1815	823	none
	14	14G	82.7	2100	49.9	1267	19.6	498	32	813	23.3	592	40	1016	25.3	643	10	254	9	229	7275	3300	none
	16	14G	108.97	2768	71.08	1806	23.58	599	32	813	26	660	44.5	1130	27.75	705	29	737	9	229	12125	5500	(12) 1-1/2" -8 UNC

Torque & Turns Chart



Class	Size	Model	Torque (ft-lbs)	Turns
Class 150	2	37H	114	1.4
	2	37G	5	18
	3	37H	114	1.5
	3	37G	5	18
	4	50H	123	2
	4	55G	7	17
	6	50H	163	2.9
	6	55G	19	19
	8	62G	41	20
	10	62G	52	18
	12	75G	69	26
	14	75G	91	28
	16V	75G	104	28
	18V	12G	125	48
	20V	12G	158	48
	24V	12G	167	60
28	14G	207	45	
30	15G	214	56	
36	15G	314	57	

Class	Size	Model	Torque (ft-lbs)	Turns
Class 300	2	37H	148	1.8
	2	37G	5	18
	3	37H	148	1.8
	3	37G	7	18
	4	50H	175	2.3
	4	55G	18	16
	6	62G	49	20
	8	75G	105	26
	10	75G	138	26
	12	12G	184	47
	14	12G	209	47
	16	12G	250	42
	18	12G	252	57
	20	14G	255	51
24	14G	411	49	
30	15G	540	56	

Class	Size	Model	Torque (ft-lbs)	Turns
Class 600	2	50H	161	1.5
	2	55G	18	13
	3	50H	161	1.5
	3	55G	28	14
	4	62G	38	17
	6	75G	117	30
	8	75G	128	31
	10	12G	184	54
	12	12G	214	56
	14	14G	323	51
	16	14G	323	51
	18	14G	476	52
	20	15G	561	55
	24	15G	898	62

H = Handwheel G = Gear Operated V = Designates a valve with a reduced weight design

Notes:

- Torque values shown are to unseat valve at maximum ΔP . Operator torques can be set up to 10% over this figure. **Electric actuators should be sized using a torque value that is 25% greater than the values listed above.**
- Turns may vary due to manufacturing tolerances and will affect operating times. Please allow +/-10% for operating times when choosing actuator gear ratio.
- Published torque values are for valves with Viton B elastomers. Please consult factory for required torque when valves contain alternative elastomers.

Class	Size	Model	Torque (ft-lbs)	Turns
Class 900	3	62G	42	20
	4	75G	120	26
	6	85G	165	28
	8	12G	192	48
	14	14G	332	48
16	15G	575	56	

Actuator Sizing

Valve choice and actuator sizing depend on factors which include:

- Service Conditions (Media Type, Temperature and Pressure)
- Access to the Handwheel
- Required Operating Speed
- Available Power Source

Automation

OmniSeal® expanding plug valves are available with Motor Adaptation Kits (MAK's) designed to accept most commercially available electric actuators. We can install, set-up and test the actuators prior to shipment of the valves from our facility. Omni Valve also offers a complete range of hydraulic actuators. Please contact Omni sales for more information or a hydraulic actuator brochure.

Most ADTR systems for the OmniSeal expanding plug valves incorporate a manually operated vent to atmosphere port as a means to monitor for leakage with the valve in the closed position. For further explanation see pages 12 and 13. Automatic Body Bleed (ABBV) systems can be used in place of the differential thermal relief systems when the OmniSeal EPV's are automated. Their intended purpose is to alleviate the need for an operator to manually vent the body to atmosphere when verifying seal integrity. This system utilizes a mechanical relief valve that is opened by the closure of the plug valve.

If a relief system is not employed, the valve could be difficult to operate or could become stuck in the closed position.

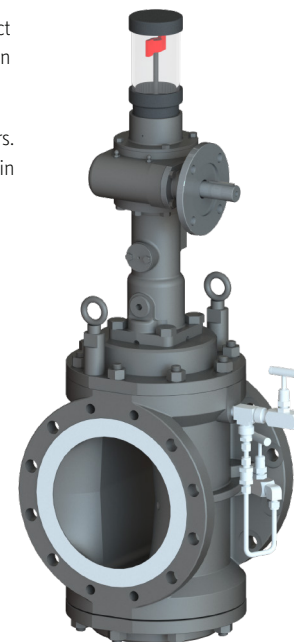

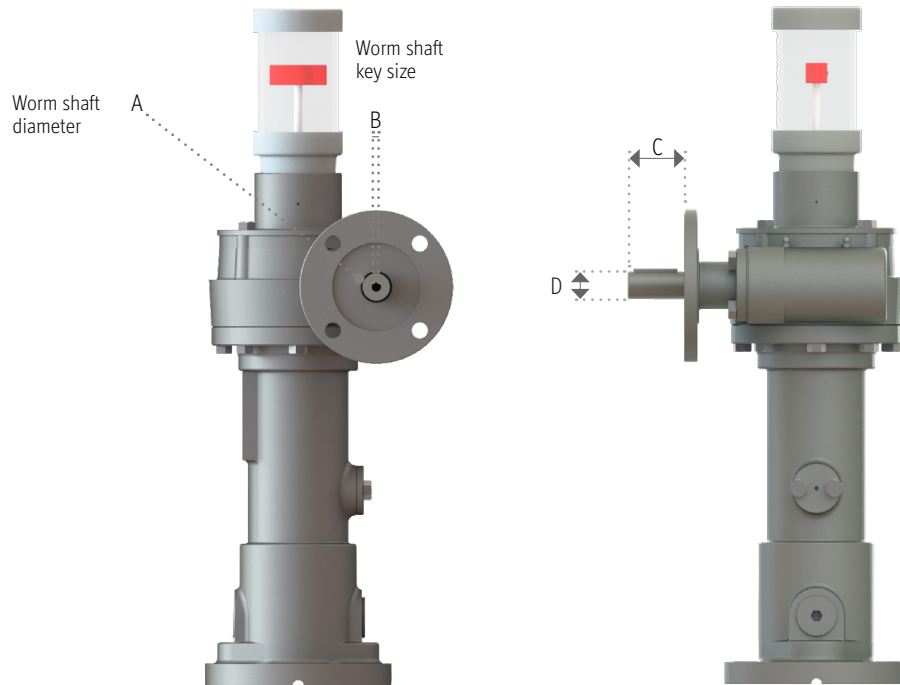

Operator	A	B	C	D	MAST
37G	.865" - .870"	0.313"	1.54"	.98"	23
55G	1.00"-1.002"	0.250"	2.60"	1.11"	75
62G	1.245"-1.247"	0.313"	2.60"	1.35"	113
75G	1.245"-1.247"	0.313"	2.60"	1.35"	225
85G	1.245"-1.247"	0.313"	2.60"	1.35"	225
12G	1.245"-1.247"	0.313"	SEE NOTE 1	1.35"	338
14G	1.618"-1.622"	0.375"	3.14"	1.82"	750
15G	1.618"-1.622"	0.375"	3.14"	1.82"	1541

Notes:

- (1) Dimension C for 12G operators is 2.50" for F10/FA10 and is 3.50" for F14/FA14 MAKs and above
- (2) Column A dimensions are of the worm shaft diameter itself. Drive Bushing bores should have between .004" and .006" clearance over the shaft dimension.
- (3) Kits contain stainless steel hardware to attach actuators. Customer must specify if actuators utilize Metric or US/Imperial hardware.
- (4) Drive shafts are dual keyed for either handwheel or actuated. Valves are supplied with appropriate key.
- (5) Dimension D is measurement over key.
- (6) MAST is Maximum allowable stem torque in ftlbs.

Maximum Allowable Torque Values

Flange Type ISO-5210	Torque (ft-lbs)	Flange Type MSS SP-102	Torque (ft-lbs)
F07	30	FA07	30
F10	73	FA10	100
F12	184		
F14	295	FA14	400
F16	516	FA16	800
F25	885	FA25	1200
F30	1843	FA30	2000
F35	3688	FA35	4500

Operator Orientation Options



OmniSeal® expanding plug valves with or without MAK's (motor adaptation kits) can be configured with a variety of gear operator orientations to allow convenient operation of the hand wheel / actuator. This will allow the user to customize the location of the hand wheel or electric actuator control panel in relation to the personnel work platform. The available orientation options for each gear operator model are shown in the chart below.

Available Orientation Positions

Operator	A	1	B	2	C	3	D	4	E	5	F	6	G	7	H	8
	0°	22.5°	45°	67.5°	90°	112.5°	135°	157.5°	180°	202.5°	225°	247.5°	270°	292.5°	315°	337.5°
37G	Y	--	--	--	Y	--	--	--	Y	--	--	--	Y	--	--	--
55G / 62G / 75G / 12G	Y	--	Y	--	Y	--	Y	--	Y	--	Y	--	Y	--	Y	--
14G / 15G	Y	Y	Y	Y	Y	Y	Y	Y	Y	Y	Y	Y	Y	Y	Y	Y

*STD

Note:
Orientation designations are determined by the position of the handwheel or actuator in relation to the bleed systems location on the valve body.

Relief system direction is determined by which flange will be "upstream" of the media flow. Examples below.

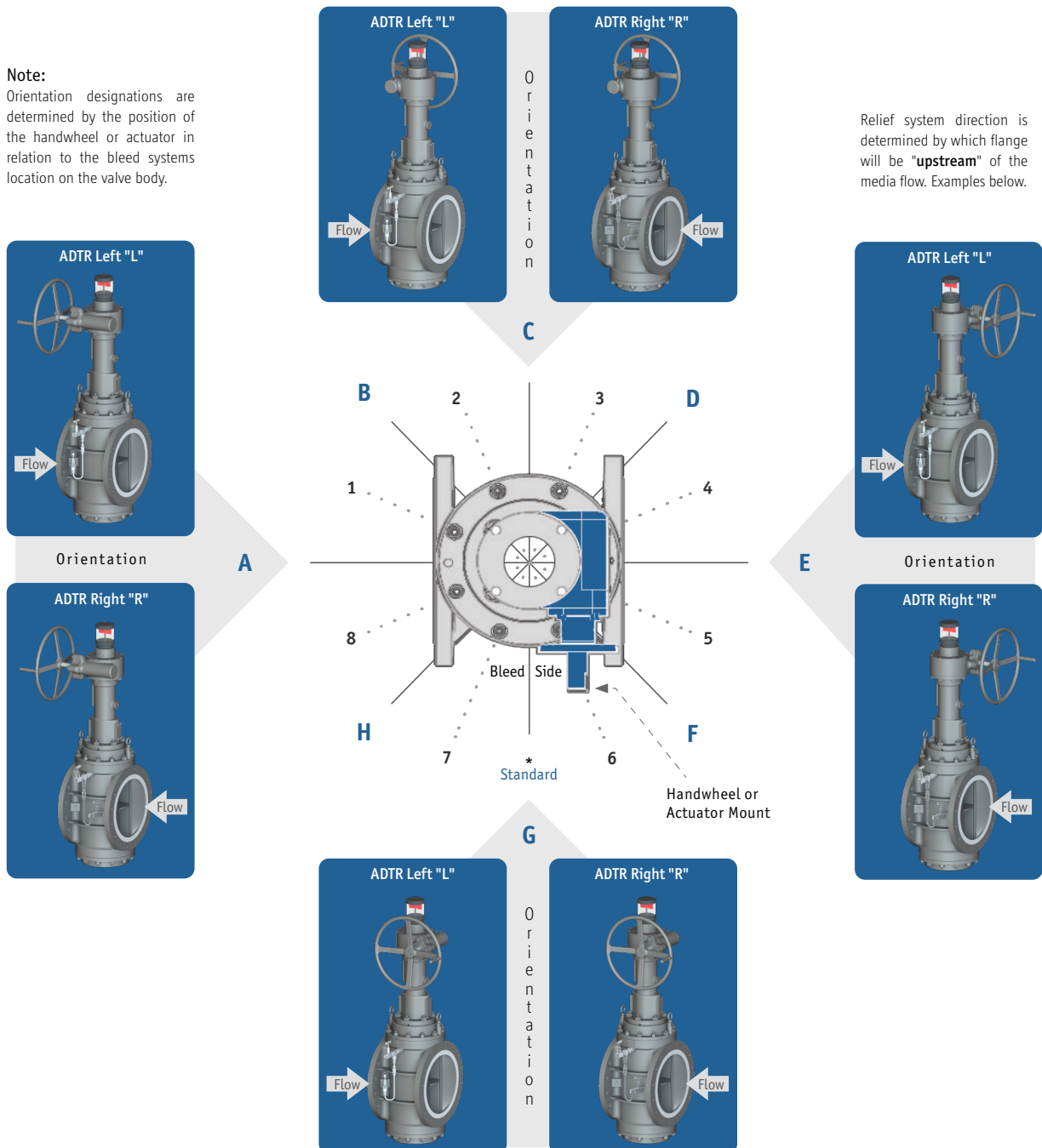



Omni Valve can provide limit switch assemblies to meet most customer's specifications. We offer assemblies that utilize a clear protective cover between the flag and the limit switch as shown in **Figure A**. This configuration eliminates any external moving parts on the assembly.

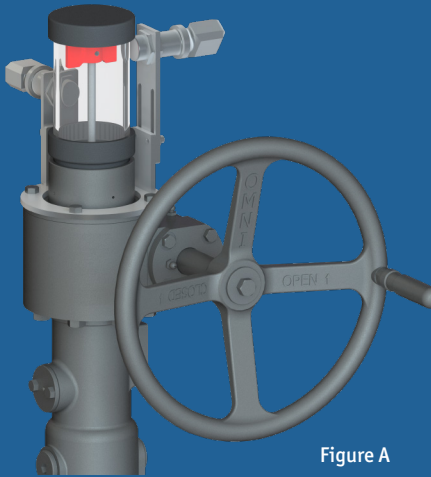

Figure A

The standard switch for this configuration is NAMUR style with a PBT thermoplastic housing that has a 10mm sensing range and utilizes a terminal compartment for wiring connections. Available approvals for this switch are listed below.

- A1. UL General Purpose
- A2. CSA General Purpose
- A3. ATEX EEx ia IIC/IIB-EEx ib IIC/IIB

An alternative configuration, without the protective cover, is available as shown in Figure B. This configuration allows a much larger selection of limit switches to be used. The assembly can be configured with a single "Open" switch or a single "Closed" switch or with both "Open" and "Closed" switches as depicted in the Figure.

The standard switch utilizes a 316 stainless steel housing with a 1/2" NPT conduit connection. The standard wiring is 18 gauge and is available in 3 ft, 6 ft, and 12 ft lengths. Contact Omni for custom wire lengths and other wiring and cabling options. The indicating flag is 17-4 PH stainless.

Available hazardous area classifications are as follows.

- B1. UL General Purpose
- B2. CSA/cUL General Purpose
- B3. UL Class 1 Divisions 1 or 2
- B4. CSA/cUL Class 1 Divisions 1 or 2
- B5. ATEX/IECEX Zone 1 Exdb or Exde
- B6. ATEX/IECEX Zone 0 Exia, T3, T4, or T6
- B7. Hi-Temp to 400°F

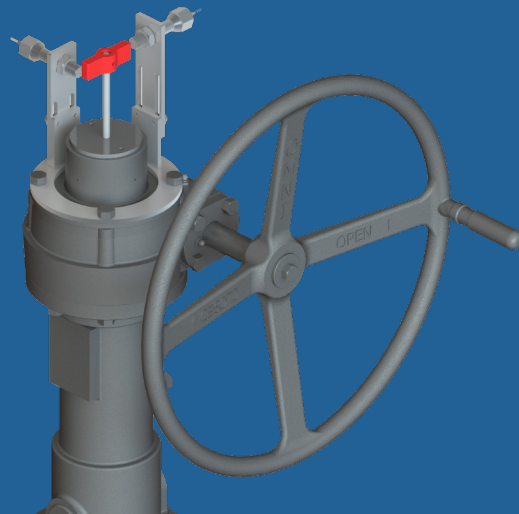

Figure B

Omni Valve can provide a wide range of custom solutions to meet customer's specifications.

The beacon unit shown in Figure C provides an intrinsically safe enclosure that houses sensing switches and a visual valve position indicator. It can be configured with a wide variety of internal sensors including: Go switches, mechanical switches, inductive sensors, and proximity switches to meet each customer's specifications. The housing is capable of containing a variety of bus network boards to facilitate valve interface and communications. The enclosure is available in aluminum, resin, or stainless steel and can be ordered with standard or metric conduit entries.

These assemblies can be certified with global agency approvals including, but not limited to: IECEx, ATEX, CE, UL, and CAS. Contact Omni for more information on beacon assemblies for specific applications.

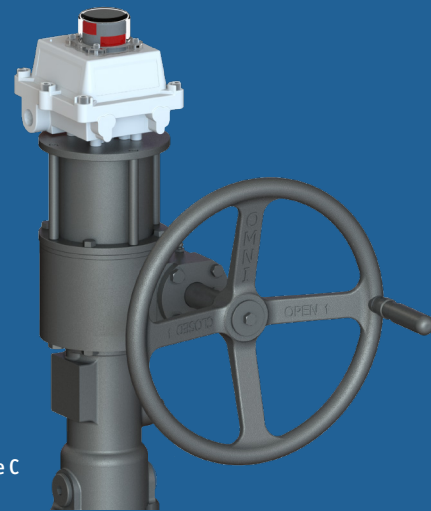

Figure C

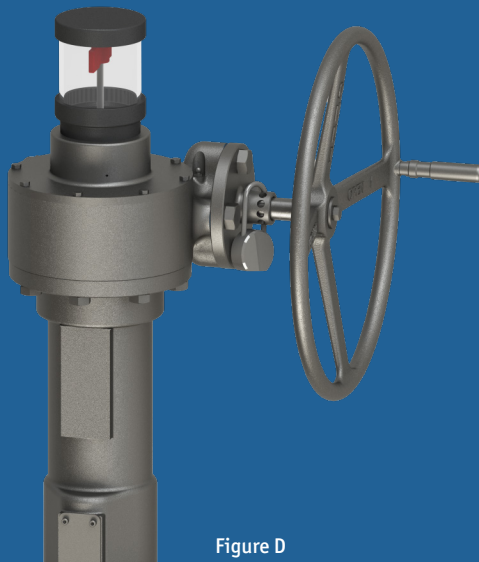

Figure D

Handwheel locking devices, as shown in Figure D, are available for the entire product line of OmniSeal® expanding plug valves to discourage tampering. These locking devices are secured using a padlock or similar mechanism and lock the valve in either the fully open or fully closed position.



OmniSeal® DB&B expanding plug valves are offered with optional stem extensions (**Type 1 or 2**), handwheel extensions (**Type 3**) and/or actuator extensions (**Type 4**).

- **Type 1 and 2** extensions move the operator gearbox away from the flow bore of the valve.
- **Type 3 and 4** extensions move the handwheel or actuator away from the vertical centerline of the valve.
- **Type 1 and 2** extensions are useful when the valve flow bore is located below grade or below a catwalk.
- **Type 3 and 4** extensions are useful when the valve is located a distance away from a catwalk.

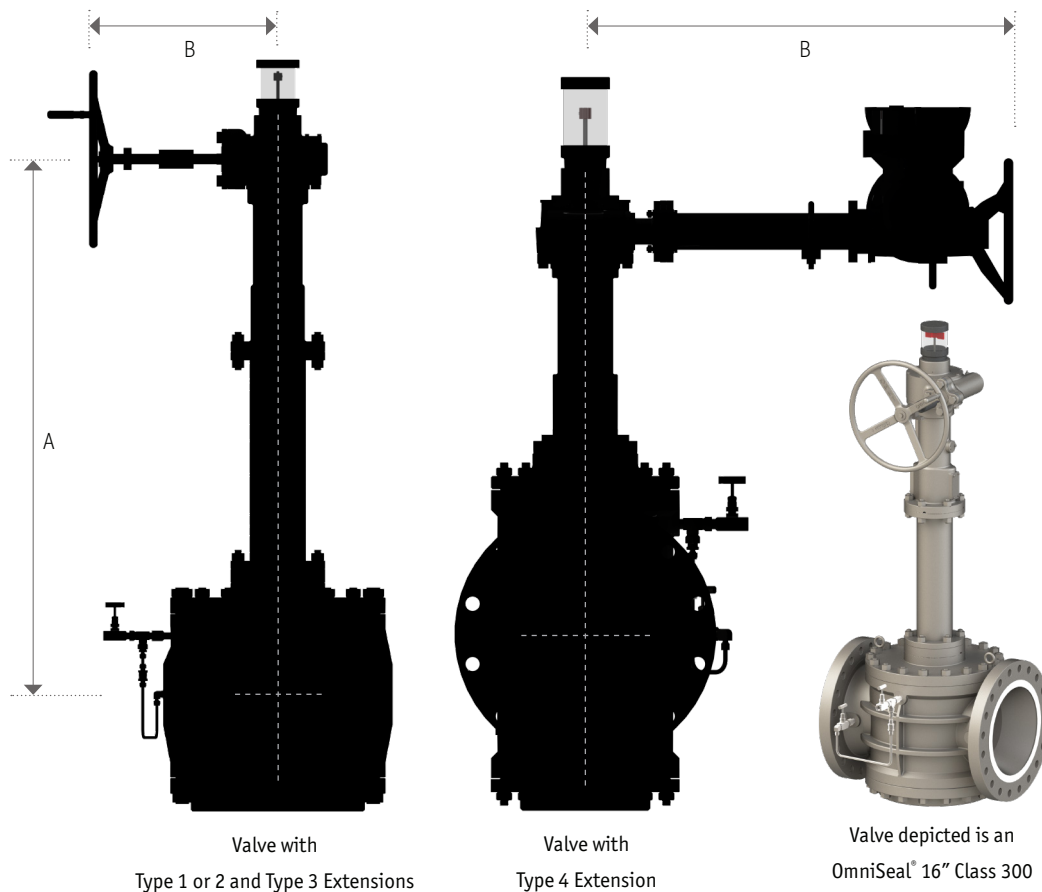

Operator Types

Type 1 – Operator Extension	Suitable for underground burial. Specify Dimension A when ordering.
Type 2 – Operator Extension	Not Suitable for underground burial. Specify Dimension A when ordering.
Type 3 – Hand Wheel Extension	It is advisable to support all hand wheel extensions. A bearing block will be supplied with all extensions for additional support by mounting to customer supplied structure. Specify B dimension when ordering.
Type 4 – Actuator Extension	Due to the weight of the actuator it is advisable to support all actuator extensions. A mounting bracket will be supplied with all extensions for mounting to customer supplied structure. Specify dimension B when ordering.

Spare Parts

Omni Valve stocks a complete line of replacement parts for the OmniSeal® DB&B expanding plug valve.

Please contact an Omni Valve sales representative for more information.



Slips

Slips for each plug valve size in standard Viton B trim are available off the shelf. Alternative seal materials are available upon request.

Indicator Protector Caps →

Indicator protector caps and shipping caps are available for all sizes.

Relief Systems and Components

Standard relief systems and components for each valve size are available off the shelf. Custom relief systems available upon request.

Omni Valve stocks various rebuild kits for the OmniSeal® DB&B expanding plug valve as follows.

Please contact an Omni Valve sales representative for more information.

Kits

Closure Kit (CK)

Class 150 / 300

(1) Body O-Ring and (1) Fire Seal Body Gasket. A closure kit is required for each of the upper and lower bonnets.

Class 600 & Above

(1) Body O-Ring, (1) Backup Ring and (1) Fire Seal Body Gasket. A closure kit is required for each of the upper and lower bonnets.

Stem Kit (SK)

(1) Stem Packing Set, (1) Stem Seal ID O-Ring and (1) Stem Seal OD O-Ring.

Rebuild Kit (RK)

(2) Closure Kits and (1) Stem Kit.

Motor Adaptation Kits (MAK)

(1) Actuator Mounting Flange and (1) Stem Spacer Sleeve and hardware.

Notes:

- (1) Stem packing is pre-formed flexible graphite.
- (2) O-Rings are 75D Viton B unless otherwise specified.
- (3) Gaskets are flexible graphite unless otherwise specified.

Figure Numbers



OmniSeal® figure numbers provide an easy way to specify the valve you need and communicate with Omni Valve or its distributors.

Please use the following format to determine the appropriate figure number for valve sizes or configurations:

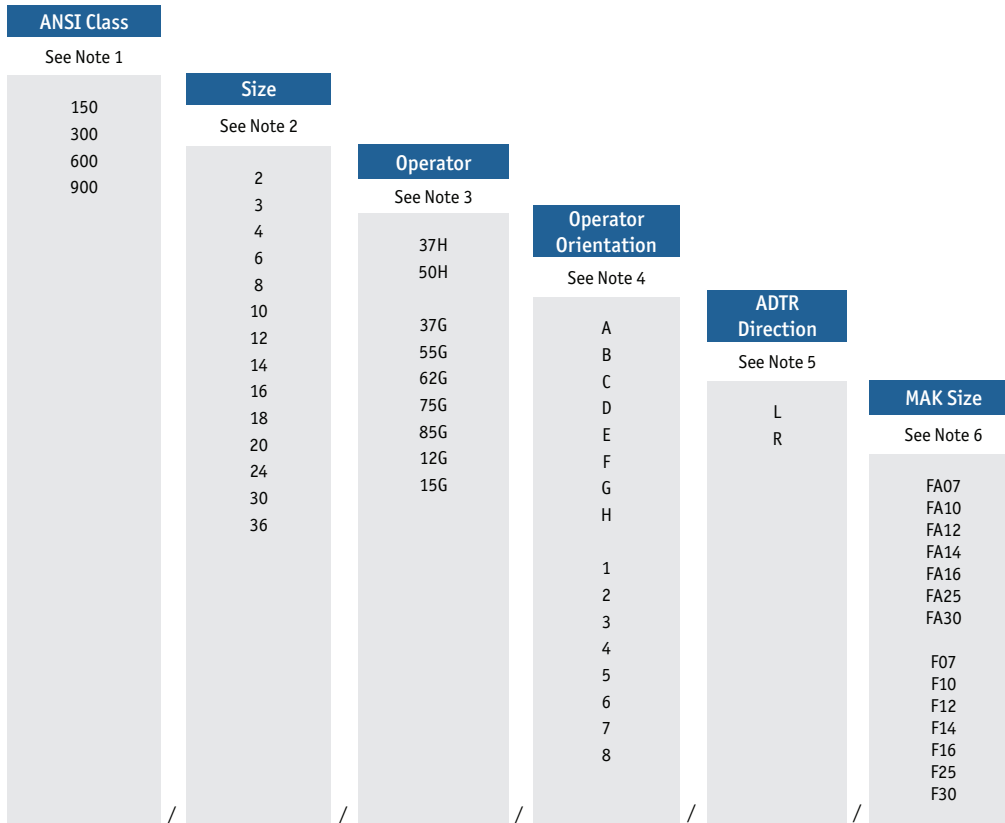

Example / / / / / = **Figure #**
150/8/62G/G/L
8" CLASS 150, 62G GEAR OPERATED, G ORIENTATION, ADTR TO LEFT HAND FLANGE, NO MAK

Example / / / / / = **Figure #**
300/12/12G/G/R/FA10
12" CLASS 300, 12G GEAR OPERATED, G ORIENTATION, ADTR TO RIGHT HAND FLANGE, FA10 MAK

Example / / / / / = **Figure #**
150/8/62G/G/L
16" CLASS 600, 14G GEAR OPERATED, C ORIENTATION, ADTR TO LEFT HAND FLANGE, NO MAK

- Notes:**
- (1) This is the ANSI Class rating for the valve flanges
 - (2) This is the bore size in inches
 - (3) This is the valve operator designation. "H" sizes refer to direct drive handwheels, "G" sizes refer to gear operators
 - (4) **See Page 21.** This is the operator orientation relative to the side of the valve upon which the bleed system is mounted. "G" is Omni standard orientation. The available orientation options for each operator are also listed on Page 21.
 - (5) See Page 21. This is the ADTR direction toward the UPSTREAM flange of the valve.
 - (6) This is the size designation for the Motor Adapter Kit (MAK), if applicable. "FA" sizes are imperial (standard) sizes, "F" sizes are metric.

Exclusive Manufacturer for OmniSeal® DBB/DIB Expanding Plug Valves

ALL OmniSeal® DB&B expanding plug valves are manufactured by Omni Valve's trusted business partner Ghatge Patil Industries LTD (GPI) in India. GPI has an ownership position in Omni Valve and its engineering, procurement and quality systems are seamlessly integrated with those of Omni Valve.

Omni Valve and GPI recognize that in today's competitive global marketplace, delivery time frame and/or logistical concerns play a key role in the success of many projects. Therefore all OmniSeal® DB&B expanding plug valve orders can be delivered from either Omni Valve's USA location or GPI's location in India depending on project requirements or customer preference. Since Omni Valve and GPI are so tightly integrated, customers can be sure that all valves have been subjected to identical quality control measures.



www.GPI.co.in



Trademarks

OmniSeal® is a registered trademark of Omni Valve. The OmniSeal® brochure contains references to other registered trademarks that are not owned by Omni Valve.

Trademarks

Viton	DuPont Performance Elastomers L.L.C.
Go Switch	Emerson Process Management

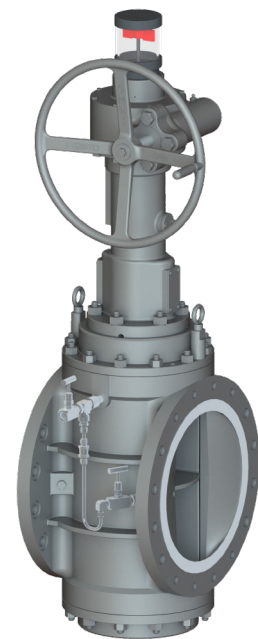

OmniSeal® Expanding Plug Valves





Absolute "ZERO" Leakage



OmniSeal[®] Double Block & Bleed Expanding Plug Valve

Omni Valve
4520 Chandler Road
Muskogee, OK 74403
USA

 (918) 687-6100

 (918) 687-6105

 pvsales@omnivalve.com

 omnivalve.com

RFQ Request For Quote

omnivalve.com/price-quote-epv.php

Product Warranty:
All products quoted are subject to Omni Valve's limited product warranty available at:
omnivalve.com/warranty.php