

2" NON-METALLIC FLAP VALVE

Air Operated Double Diaphragm (AODD) Pump

SANDPIPER
A WARREN RUPP, INC. BRAND



The 2" Heavy Duty Non-Metallic Flap Valve Pump has been designed to solve the most common problems in mine dewatering, sump, and chemical transfer applications.



Bottom Discharge

Gravity assist is ideal for pumping liquids with settling solids



ESADS+Plus Air Valve

Externally Serviceable Air Distribution System



Best-in-class air consumption

Less than 65 SCFM at Max pump flow



Lightweight & Portable

At 53 lbs (24 kg) it is safely and easily transported



All Bolted Construction

Rugged, leak free design

Solids Range

Up to 1.8" (46mm)

Flap Check Valves

Performance & solids handling

Superior Dry Prime

Up to 20' (6.1 m) of water

Porting Options

Optional flanged or threaded connection



REDEFINING THE FLAP VALVE PUMP

YOUR MINING, GENERAL INDUSTRIAL & CHEMICAL SOLUTION

The robust, yet lightweight design allows for ease of maintenance and movement, and is ideal for handling solids and corrosive fluids. This unique pump has been engineered to fully function in any position, includes lifting handles and hanging points, and has durable mounting feet. This is an ideal solution for numerous applications.



Lightweight & Durable

The non-metallic, lightweight design makes it easily portable at 53 lbs (24 kg)



Reliability Guarantee

Strongest diaphragm connecting rod in the industry is guaranteed to not bend or yield in operation



Rugged Design

Stainless steel seats prevent abrasion when pumping solids laden fluids



Optimum Solids Handling

Hinge pads exert positive pressure on the flaps, allowing the pump to operate in virtually any position; they help deliver superior suction lift and flow rates



Long Life

A proven diaphragm design in conjunction with exclusive wear pads reduce plate abrasion, delivering extended life



Purpose Built Base

The threaded version features stainless steel mounting feet and the flanged version features Polypropylene mounting feet

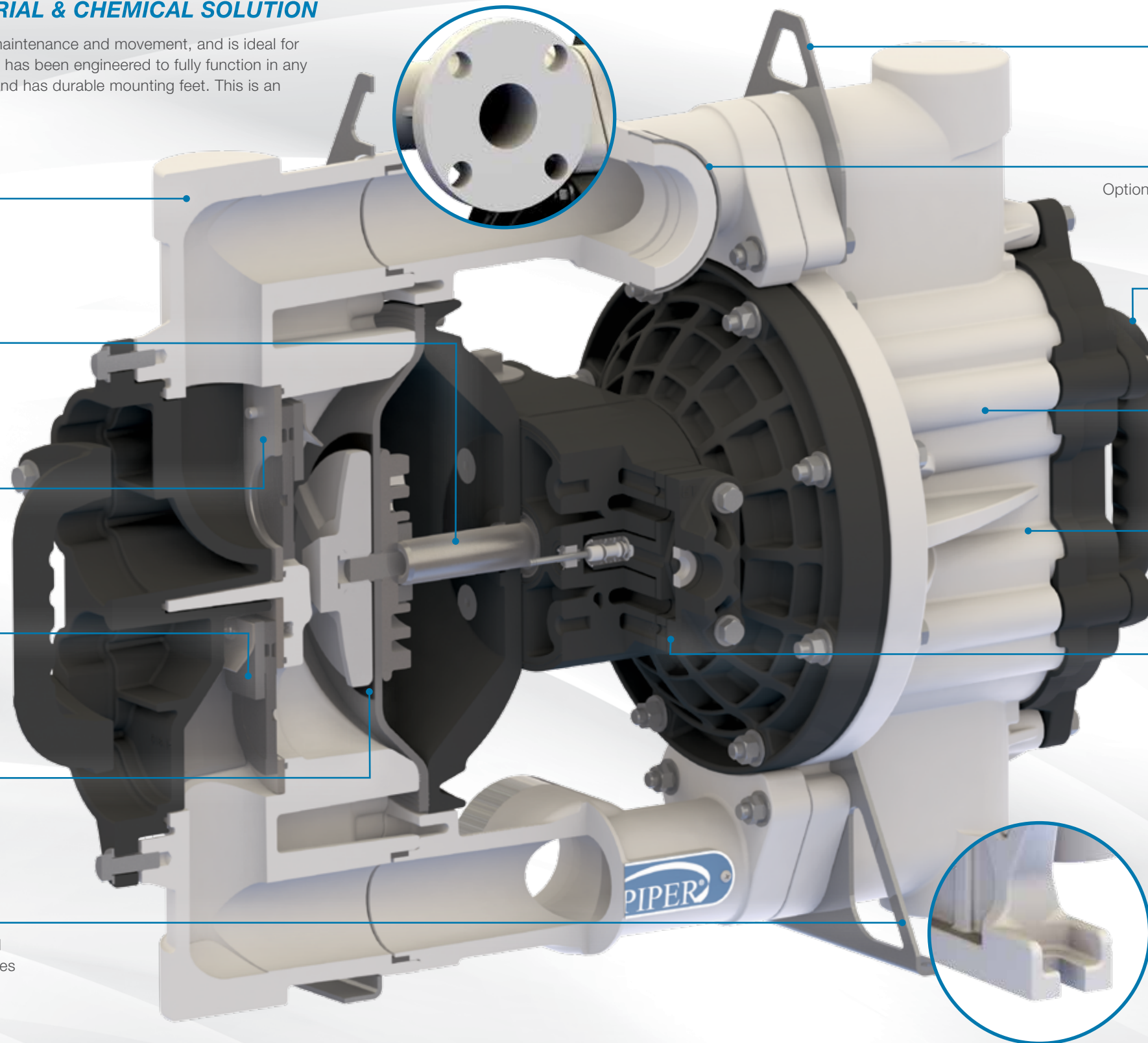

Industrial Mounting Capabilities

Addition of stainless steel hanging points located on the manifold allow for multiple mounting options



Strong Manifold Connections

Optional flanged or threaded connection for additional flexibility; Stainless steel reinforcing rings help protect the threaded manifold connections from being damaged



Ergonomic Handle

Lifting handles come standard, allowing for easy pump transport; handles can be rotated 90 degrees for proper ergonomics, depending on desired use



Unsurpassed Performance

Industry leading flow rates, suction lift, air efficiency and displacement per stroke



Versatile Design

This pump will function in any position, including uneven surfaces



Simple Maintenance

With our signature ESADS+Plus (Externally Serviceable Air Distribution System) air valve design and externally serviceable flap valve modules, in-field service is quick and easy, saving you from unnecessary downtime



Visit SANDPIPERPUMP.COM/ESADSVideos to see how easy the ESADS air valve makes maintaining the 2" Non-Metallic Flap Valve.

PERFORMANCE & DIMENSIONS

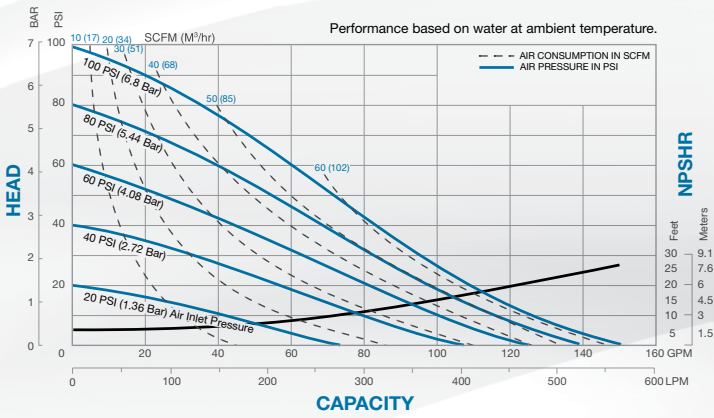

Max Capacity

150 GPM (568 LPM)

Displacement Per Stroke

.50 Gal (1.9 L)

Max Discharge Pressure

100 PSI (7.0 BAR)

Pipe Size

2" NPT / BSP / ANSI / DIN Flange

Max Solids Handling

1.8" (46mm)

Air End/Wet End

Polypropylene / Stainless Steel Seats (Wet End Only)

HD20F Non-Metallic with Threaded Porting

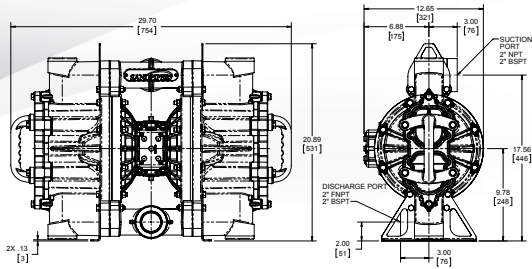

HD20F Non-Metallic with Flanged Porting

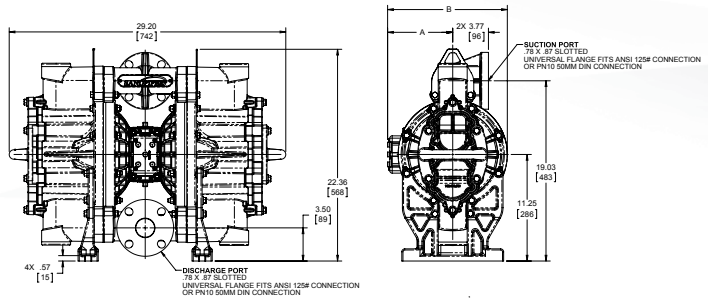

EASE OF MAINTENANCE

To help increase productivity and reduce downtime, the 2" Non-Metallic Flap Valve Pump was engineered with ease of maintenance in mind.

QUICK ACCESS TO SERVICEABLE COMPONENTS

- 1. Remove Clean-Out Cap**
By simply removing six bolts securing the clean-out cap in place, it allows access to clear simple clogs without disassembling the entire pump
- 2. Modular Check Valve Access**
With the clean-out cap removed, the flap valves can be inspected and / or replaced as needed; four bolts hold the modular flap valves in place for quick maintenance and repair
- 3. ESADS+Plus**
Proven air distribution system allows for maintenance and / or repair of both pilot valve and air valve components without removing the pump from service

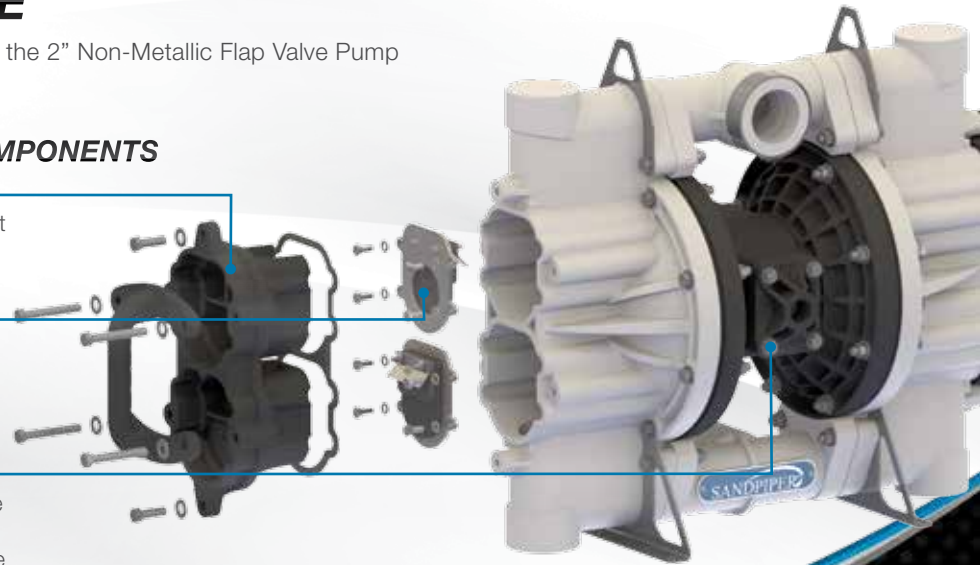

Warren Rupp, Inc.
A Unit of IDEX Corporation
800 North Main Street
Mansfield, OH 44902 USA



Phone: 419.524.8388
Fax: 419.522.7867
SANDPIPERPUMP.COM



Contact Your Local Distributor to Place Your Order:

