

## FreFlow

Horizontal centrifugal pump

FRE/EN (1710) 9.3

Original instructions

Read and understand this manual prior to operating or servicing this product

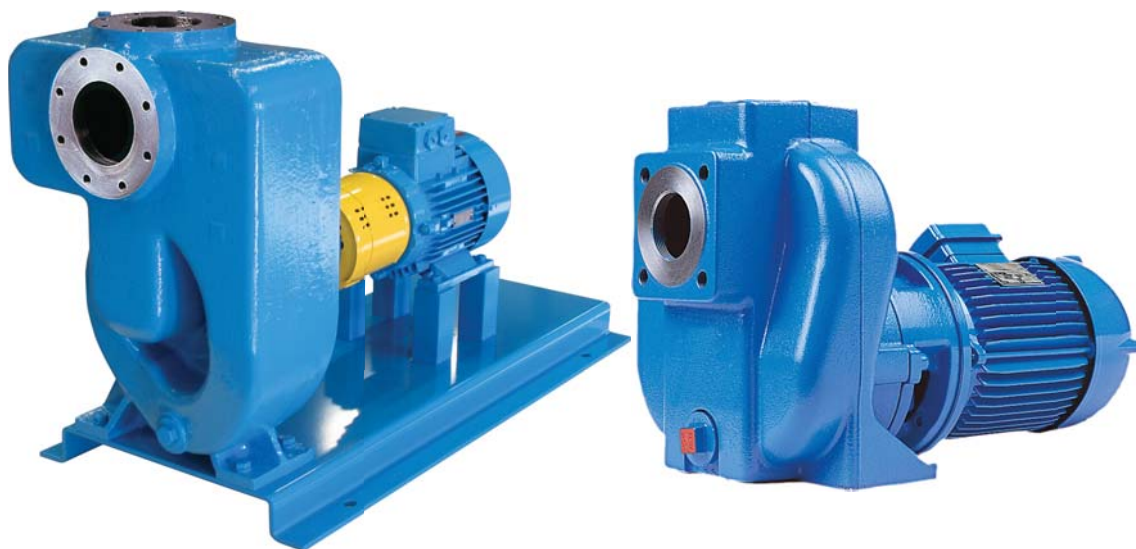



## EC Declaration of conformity

(Directive 2006/42/EC, appendix II-A)

### Manufacturer

SPX Flow Technology Assen B.V.  
Dr. A.F. Philipsweg 51  
9403 AD Assen  
The Netherlands

hereby declares that all pumps member of productfamilies CombiBloc, CombiBlocHorti, CombiChem, CombiDirt, CombiFlex(U)(B), CombiPrime H, CombiLine, CombiLineBloc, CombiMag, CombiMagBloc, CombiNorm, CombiPro(L)(M)(V), CombiPrime V, CombiSump, CombiTherm, CombiWell, FRE, FRES, FREF, FREM, KGE(L), KGEF, HCR, MCH(W)(S), MCHZ(W)(S), MCV(S), PHA, MDR whether delivered without drive (last position of serial number = B), or delivered as an assembly with drive (last position of serial number = A), are in conformity with the provisions of Directive 2006/42/EC (as altered most recently) and where applicable the following directives and standards:

- EC directive 2014/35/EU, "Electric equipment for use within certain voltage limits"
- standards EN-ISO 12100 part 1 & 2, EN 809

The pumps to which this declaration refers may only be put into operation after they have been installed in the way prescribed by the manufacturer, and, as the case may be, after the complete system of which these pumps form part, has been made to fulfil the requirements of Directive 2006/42/EC (as altered most recently).

## Declaration of incorporation

(Directive 2006/42/EC, appendix II-B)

### Manufacturer

SPX Flow Technology Assen B.V.  
Dr. A.F. Philipsweg 51  
9403 AD Assen  
The Netherlands

hereby declares that the partly completed pump (Back-Pull-Out unit), member of productfamilies CombiBloc, CombiBlocHorti, CombiChem, CombiDirt, CombiFlex(U)(B), CombiPrime H, CombiLine, CombiLineBloc, CombiMag, CombiMagBloc, CombiNorm, CombiPro(L)(M)(V), CombiTherm, CombiPrime V, FRE, FRES, FREF, FREM, KGE(L), KGEF, HCR, PHA, MDR is in conformity with the following standards:

- EN-ISO 12100 parts 1 & 2, EN 809

and that this partly completed pump is meant to be incorporated into the specified pump unit and may only be put into use after the complete machine of which the pump under consideration forms part has been made and declared to comply with that directive.

Assen, September 1st 2016

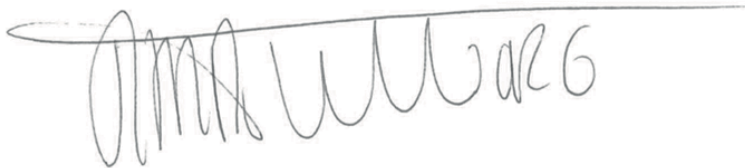

R. van Tilborg,  
Managing Director



## Instruction manual

All technical and technological information in this manual as well as possible drawings made available by us remain our property and shall not be used (otherwise than for the operation of this pump), copied, duplicated, made available to or brought to the notice of third parties without our prior written consent.

SPXFLOW is a global multi-industry manufacturing leader. The company's highly-specialized, engineered products and innovative technologies are helping to meet rising global demand for electricity and processed foods and beverages, particularly in emerging markets.

SPX Flow Technology Assen B.V.  
P.O. Box 9  
9400 AA Assen  
The Netherlands  
Tel. +31 (0)592 376767  
Fax. +31 (0)592 376760

Copyright © 2015 SPXFLOW Corporation



# Table of Contents

<b>1</b>	<b>Introduction</b>	<b>9</b>
1.1	Preface	9
1.2	Safety	9
1.3	Guarantee	10
1.4	Inspection of delivered items	10
1.5	Instructions for transport and storage	10
1.5.1	Weight	10
1.5.2	Use of pallets	10
1.5.3	Hoisting	11
1.5.4	Storage	12
1.6	Ordering parts	12
<b>2</b>	<b>General</b>	<b>13</b>
2.1	Pump description	13
2.2	Type code	13
2.3	Serial number	14
2.4	Pump/motor group	14
2.5	Bearing groups	14
2.6	Applications	14
2.7	Selfpriming action	15
2.8	Configurations	16
2.9	Construction	16
2.9.1	Pump casing and impeller	16
2.9.2	Bearing bracket construction	16
2.9.3	Mechanical seal	16
2.10	Materials	17
2.11	Connections	17
2.12	Application area	17
2.13	Re-use	17
2.14	Scrapping	17
<b>3</b>	<b>Installation</b>	<b>19</b>
3.1	Safety	19
3.2	Preservation	19
3.3	Environment	19
3.4	Mounting	20
3.4.1	Installation of a pump unit	20
3.4.2	Assembling a pump unit	20
3.4.3	Alignment of the coupling	20
3.4.4	Tolerances for aligning the coupling	21

3.5	Installation of pumps with flanged-on motors	21
3.6	Main piping connection	21
3.7	Piping	22
3.8	Connection of the electric motor	23
3.9	Combustion engine	23
3.9.1	Safety	23
3.9.2	Sense of rotation	23
<b>4</b>	<b>Commissioning</b>	<b>25</b>
4.1	Inspection of the pump	25
4.2	Inspection of the motor	25
4.3	Oil chamber	25
4.4	Checking the sense of rotation	25
4.5	Start-up	26
4.6	Pump in operation	26
4.7	Noise	26
<b>5</b>	<b>Maintenance</b>	<b>27</b>
5.1	Daily maintenance	27
5.2	Combustion engine	27
5.3	Mechanical seal	27
5.4	Double mechanical seal	27
5.5	Environmental influences	28
5.6	Noise	28
5.7	Motor	28
5.8	Faults	28
<b>6</b>	<b>Problem solving</b>	<b>29</b>
<b>7</b>	<b>Disassembly and assembly</b>	<b>31</b>
7.1	Precautionary measures	31
7.2	Special tools	31
7.3	Draining	31
7.3.1	Liquid draining	31
7.4	Constructive variants	31
7.5	Back-Pull-Out system	32
7.5.1	Disassembling the guard	32
7.5.2	Disassembly Back Pull Out-unit	32
7.5.3	Assembly Back Pull Out-unit	32
7.5.4	Assembling the guard	32
7.6	Replacing the impeller and the wear ring	35
7.6.1	Measuring clearance between impeller and wear plate, FRE bearing group 1	35
7.6.2	Measuring clearance between impeller and wear plate, other bearing groups	36
7.6.3	Disassembly of the impeller, bearing bracket 1	36
7.6.4	Assembly of the impeller, bearing bracket 1	37
7.6.5	Disassembly of the impeller, other bearing brackets	37
7.6.6	Assembly of the impeller, other bearing brackets	37
7.6.7	Disassembly of the wear plate	37
7.6.8	Assembly of the wear plate	37
7.6.9	Disassembling the wear ring	38
7.6.10	Assembling the wear ring	38
7.7	Mechanical seal	39
7.7.1	Instructions for mounting a mechanical seal	39
7.7.2	Disassembly of the mechanical seal MG12	39
7.7.3	Assembly of the mechanical seal MG12	39
7.7.4	Disassembly of the mechanical seal M7N	40



7.7.5	Assembly of the mechanical seal M7N	40
7.7.6	Disassembly of double mechanical seal MD1	41
7.7.7	Assembly double mechanical seal MD1	41
7.8	Bearing	42
7.8.1	Instructions for assembly and disassembly of bearings	42
7.8.2	Disassembly of the bearings FRE - bearing bracket 1	42
7.8.3	Assembly of the bearings FRE - bearing bracket 1	43
7.8.4	Disassembly of the bearings FRE - bearing bracket 2	43
7.8.5	Assembly of the bearings FRE - bearing bracket 2	43
7.8.6	Disassembly of the bearings FRE - bearing bracket 3	44
7.8.7	Assembly of the bearings FRE - bearing bracket 3	44
7.8.8	Disassembly of the bearings FRE 80-210 and 100-250	45
7.8.9	Assembly of the bearings FRE 80-210 and 100-250	45
7.8.10	Disassembly of the bearings FRE 150-290b and 150-290	46
7.8.11	Assembly of the bearings 150-290b and 150-290	46
7.9	FRES	47
7.9.1	Assembly of the electric motor	47
7.9.2	Adjusting the impeller	47
7.10	FREF	48
7.10.1	Assembly of the electric motor	48
7.11	FREM	48
7.11.1	Assembly combustion engine	48
7.11.2	Adjusting the impeller	48
<b>8</b>	<b>Dimensions</b>	<b>49</b>
8.1	FRE - bearing groups 1,2 and 3	49
8.2	FRE - bearing group 4	51
8.3	FRE with ISO 7005 PN20 connections	52
8.4	FRE - pump unit A6	55
8.5	FRE - pump unit A6, with ISO 7005 PN20 connections	60
8.6	FRES	65
8.7	FRES with ISO 7005 PN20 connections	67
8.8	FREM	71
8.9	FREF	74
<b>9</b>	<b>Parts</b>	<b>75</b>
9.1	Ordering parts	75
9.1.1	Order form	75
9.1.2	Recommended spare parts	75
9.2	Pump FRE - bearing group 1	76
9.2.1	Sectional drawing FRE - bearing group 1	76
9.2.2	Parts list FRE - bearing group 1	77
9.3	Pump FRE - bearing group 2	78
9.3.1	Sectional drawing FRE - bearing group 2	78
9.3.2	Parts list FRE - bearing group 2	79
9.4	Pump FRE - bearing group 3	80
9.4.1	Sectional drawing FRE - bearing group 3	80
9.4.2	Parts list FRE - bearing group 3	81
9.5	Pump parts FRE 80-210 and 100-250	82
9.5.1	Sectional drawing FRE 80-210 and 100-250	82
9.5.2	Parts list FRE 80-210 and 100-250	83
9.6	Pump parts FRE 150-290b and 150-290	84
9.6.1	Sectional drawing FRE 150-290b and 150-290	84
9.6.2	Parts list FRE 150-290b and 150-290	85
9.7	Pump parts FRES	86

9.7.1	Sectional drawing FRES	86
9.7.2	Parts list FRES	87
9.8	Pump parts FREF	88
9.8.1	Sectional drawing FREF	88
9.8.2	Parts list FREF	89
9.9	Pump parts FREM	90
9.9.1	Sectional drawing FREM	90
9.9.2	Parts list FREM	91
9.10	Parts Mechanical seal MQ1	92
9.10.1	Sectional drawings Mechanical seal MQ1	92
9.10.2	Parts list Mechanical seal MQ1	93
9.11	Parts FRE - plan 11	94
9.11.1	Sectional drawing FRE - plan 11	94
9.11.2	Parts list FRE - plan 11	94
9.12	Parts Double mechanical seal MD1	95
9.12.1	Sectional drawing Double mechanical seal MD1	95
9.12.2	Parts list Double mechanical seal MD1	95
9.13	Parts Cutting mechanism	96
9.13.1	Sectional drawing Cutting mechanism	96
9.13.2	Parts list Cutting mechanism	96
<b>10</b>	<b>Technical data</b>	<b>97</b>
10.1	Oil chamber	97
10.2	Recommended locking liquids	97
10.3	Tightening moments	97
10.3.1	Tightening moments for bolts and nuts	97
10.3.2	Tightening moments set screw from coupling	98
10.4	Hydraulic performance	99
10.5	Permissible forces and moments on the flanges	101
10.6	Noise data	103
10.6.1	Pump noise as a function of pump power	103
10.6.2	Noise level of entire pump unit	104
	<b>Index</b>	<b>105</b>
	<b>Order form for spare parts</b>	<b>107</b>

# 1 Introduction

## 1.1 Preface

This manual is intended for technicians and maintenance staff and for those who are in charge of ordering spare parts.

This manual contains important and useful information for the proper operation and maintenance of this pump. It also contains important instructions to prevent potential accidents and damage, and to ensure safe and fault-free operation of this pump.



**Read this manual carefully before commissioning the pump, familiarize yourself with the operation of the pump and strictly obey the instructions!**

The data published here comply with the most recent information at the time of going to press. However they may be subject to later modifications.

SPXFLOW reserves the right to change the construction and design of the products at any time without being obliged to change earlier deliveries accordingly.

## 1.2 Safety

This manual contains instructions for working safely with the pump. Operators and maintenance staff must be familiar with these instructions.

Installation, operation and maintenance has to be done by qualified and well prepared personnel.

Below is a list of the symbols used for those instructions and their meaning:



***Personal danger for the user. Strict and prompt observance of the corresponding instruction is imperative!***



**Risk of damage or poor operation of the pump. Follow the corresponding instruction to avoid this risk.**



*Useful instruction or tip for the user.*

Items which require extra attention are shown in **bold print**.

This manual has been compiled by SPXFLOW with the utmost care. Nevertheless SPXFLOW cannot guarantee the completeness of this information and therefore assumes no liability for possible deficiencies in this manual. The buyer/user shall at all times be responsible for testing the information and for taking any additional and/or deviating safety measures. SPXFLOW reserves the right to change safety instructions.

## 1.3 Guarantee

SPXFLOW shall not be bound to any guarantee other than the guarantee accepted by SPXFLOW. In particular, SPXFLOW will not assume any liability for explicit and/or implicit guarantees such as but not limited to the marketability and/or suitability of the products supplied.

The guarantee will be cancelled immediately and legally if:

- Service and/or maintenance is not undertaken in strict accordance with the instructions.
- The pump is not installed and operated in accordance with the instructions.
- Necessary repairs are not undertaken by our personnel or are undertaken without our prior written permission.
- Modifications are made to the products supplied without our prior written permission.
- The spare parts used are not original SPXFLOW parts.
- Additives or lubricants used are other than those prescribed.
- The products supplied are not used in accordance with their nature and/or purpose.
- The products supplied have been used amateurishly, carelessly, improperly and/or negligently.
- The products supplied become defective due to external circumstances beyond our control.

**All parts which are liable to wear are excluded from guarantee.** Furthermore, all deliveries are subject to our "General conditions of delivery and payment", which will be forwarded to you free of charge on request.

## 1.4 Inspection of delivered items

Check the consignment immediately on arrival for damage and conformity with the advice note. In case of damage and/or missing parts, have a report drawn up by the carrier at once.

## 1.5 Instructions for transport and storage

### 1.5.1 Weight

A pump or a pump unit is generally too heavy to be moved by hand. Therefore, use the correct transport and lifting equipment. Weight of the pump or pump unit are shown on the label on the cover of this manual.

### 1.5.2 Use of pallets

Usually a pump or pump unit is shipped on a pallet. Leave it on the pallet as long as possible to avoid damages and to facilitate possible internal transport.



**When using a forklift always set the forks as far apart as possible and lift the package with both forks to prevent it from toppling over! Avoid jolting the pump when moving it!**

1.5.3 Hoisting

When hoisting a pump or complete pump units the straps must be fixed in accordance with figure 1, figure 2 and figure 3.



**When lifting a pump or a complete pump unit always use a proper and sound lifting device, approved to bear the total weight of the load!**



**Never go underneath a load that is being lifted!**



**If the electric motor is provided with a lifting eye, this lifting eye is intended only for the purpose of carrying out service activities to the electric motor! The lifting eye is designed to bear the weight of the electric motor only! It is NOT permitted to lift a complete pump unit at the lifting eye of an electric motor!**

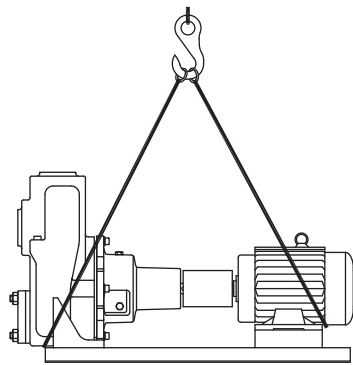

Figure 1: Lifting instructions for pump unit.

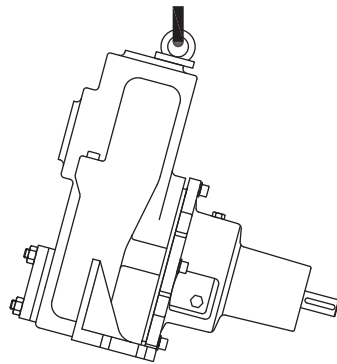

Figure 2: Lifting instructions for single pump.

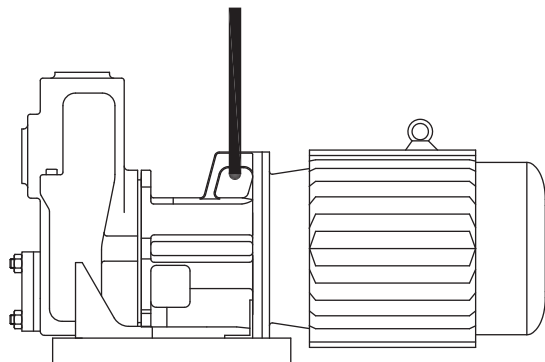

Figure 3: Lifting instructions FRES.

## 1.5.4 Storage

If the pump is not to be used immediately the pump shaft must be turned by hand twice per week.

## 1.6 Ordering parts

This manual contains a survey of the spare parts recommended by SPXFLOW as well as the instructions for ordering them. A fax-order form is included in this manual.

You should always state all data stamped on the type plate when ordering parts and in any other correspondence regarding the pump.

➤ *This data is also printed on the label on the front of this manual.*

If you have any questions or require further information with regard to specific subjects, then do not hesitate to contact SPXFLOW.

## 2 General

### 2.1 Pump description

FreFlow pumps are self-priming centrifugal pumps with a half open or closed impeller and a mechanical seal. The pumps come in cast iron, bronze or stainless steel construction. FreFlow pumps can be used for handling clean and polluted liquids.

### 2.2 Type code

Pumps are available in various designs. The main characteristics of the pump are shown in the type code.

Example: **FRE 50-125 G1 MQ1**

Pump construction	
<b>FRE</b>	pump with bearing bracket
<b>FREF</b>	pump with flanged electric motor and extended shaft
<b>FRES</b>	pump with flanged motor (IEC standard)
<b>FREM</b>	pump with flanged combustion engine
Pump size	
<b>50-125</b>	suction and discharge connections [mm] - impeller diameter [mm]
Pump casing and impeller material	
<b>G1</b>	cast iron pump casing and impeller
<b>G2</b>	cast iron pump casing, bronze impeller
<b>G6</b>	cast iron pump casing, stainless steel impeller
<b>B2</b>	bronze pump casing and impeller
<b>R6</b>	stainless steel pump casing and impeller
Shaft sealing	
<b>MQ0</b>	mechanical seal unbalanced non-EN standard, with (oil) quench
<b>MQ1</b>	mechanical seal unbalanced EN 12756, with (oil) quench
<b>MD1</b>	mechanical seal double unbalanced EN 12756

## 2.3 Serial number

Serial number of the pump or pump unit are shown on the name plate off the pump and on the label on the cover of this manual.

Example: **01-1000675A**

01	year of manufacture
100067	unique number
5	number of pumps
A	pump with motor
B	pump with free shaft end

## 2.4 Pump/motor group

There is also a designation for the pump / motor group:

- Pumps with bare shaft are designated by an "A" (FRE).
- Pumps complete with all parts, to be assembled with the motor, but supplied without the motor are designated by "A5" (FRE).
- Pumps assembled with:
  - three-phase electric motor are designated by "A6" (FRE, FRES and FREF).
  - single-phase electric motor are designated by "A7" (FREF).
  - petrol engine are designated by "A10" (FREM)
  - diesel engine are designated by "A11" (FREM)

## 2.5 Bearing groups

FreFlow pumps can be divided into 4 categories of bearing bracket groups, i.e. groups 1, 2, 3 and 4. Groups 1, 2 and 3 are of modular construction. Pumps that are part of one such group share their bearing bracket.

➤ *Pumps of group 4 (higher capacity) each have their own bearing bracket but will for convenience sake be identified as bearing bracket group 4.*

## 2.6 Applications

- FreFlow pumps are suitable for handling clean, polluted and thin liquids. The maximum particle size of impurities depends on the pump size. In handling viscous liquids, you should make allowance for a decrease in hydraulic performance and an increase in power consumption. Please ask us for advice.
- The maximum allowed system pressure and temperature and the maximum speed depend on the pump type and the pump construction. For relevant data see the tables in chapter 10 "Technical data"
- Further details about the application possibilities of your specific pump are mentioned in the order confirmation and/or in the data sheet enclosed with the delivery.
- Please do not use the pump for purposes other than those for which it is delivered without prior consultation with your supplier.



***Using a pump in a system or under system conditions (liquid, working pressure, temperature, etc.) for which it has not been designed may hazard the user!***



**2.7 Selfpriming action**

FreFlow pumps are of the selfpriming type. A separate air pump or any other equipment is not required. Suction lifts up to 7 m are possible. The selfpriming action relies on the principle of injection. The pump has to be filled with liquid once. When it has been switched on, the air (or gas) is evacuated from the suction line.

The aspirated air is mixed with the liquid contained in the impeller. Through the centrifugal force, the liquid / air mixture from the volute flows to the upper half of the pump casing. In the generously sized pump casing the liquid can be de-aerated. The air escapes to the discharge line. The de-aerated liquid has a higher specific gravity than the liquid with air contained the volute. This causes the liquid to return to the volute (with some pumps -bearing group 4- the liquid flows back through the impeller inlet), where it is aerated and then de-aerated again in the upper part of the pump casing. The air is evacuated from the suction line and the liquid level in this piping rises.

Once all air has been evacuated, the pump starts to run as a normal centrifugal pump. A precondition for good functioning is that it should be possible for the aspirated air to escape without back pressure in the discharge line. The pump does not have a non-return valve, so the suction and discharge lines can be siphoned empty, when the pump has been stopped. The remaining liquid in the pump casing is always sufficient for the next suction phase. In case voluminous suction piping causing too long suction times, it is recommended to install a non return valve in the pumps suction inlet.

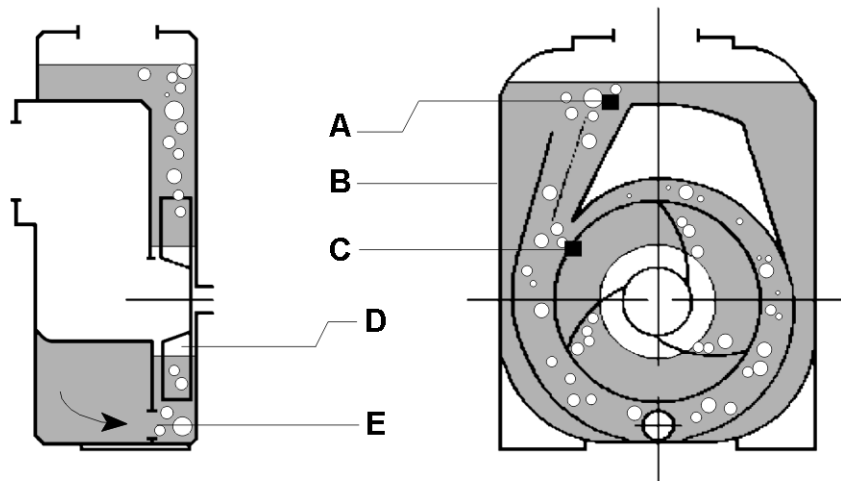

<b>A</b>	Water /air separation
<b>B</b>	Pump casing
<b>C</b>	Volute
<b>D</b>	Impeller
<b>E</b>	Back flow opening

## 2.8 Configurations

There are 4 different configurations in the FreFlow range:

- Type FRE : Pump with bearing bracket
- Type FRES : Pump with stub shaft and lantern piece coupled to an IEC flange motor
- Type FREF : Pump with lantern piece, coupled to a flange motor with extended shaft end
- Type FREM : Pump with stub shaft and lantern piece coupled to a petrol or diesel engine

## 2.9 Construction

### 2.9.1 Pump casing and impeller

The pump casing is a combination of a volute and aeration chamber, to ensure the selfpriming action. There is a generously sized drain hole at the bottom of the pump casing, which can also be used for cleaning. Dependent on the pump size, the pump is fitted with a half open or closed impeller. The half open impellers have 3 or 4 blades with a generously sized passage. Pumps with a half open impeller come with a renewable wear plate between pump casing wall and impeller blades. Pumps with a closed impeller have a renewable wear ring fitted in the pump casing, around the impeller entry. This wear plate / wear ring enables the pump to be overhauled at minimum cost.

### 2.9.2 Bearing bracket construction

- In the FRE configuration, pumps are fitted with a shaft supported in two generously sized, grease lubricated ball bearings.
- Pumps of the FRES and FREM types come with a stub shaft which can be mounted on the mother shaft without play.
- Pumps of the FREF range have the impeller fitted on the extended motor shaft. In the FRES, FREF and FREM configurations the motor is fitted to the pump casing, using a lantern piece.

### 2.9.3 Mechanical seal

All pump types of FRE, FRES and FREM are equipped with a mechanical seal according to EN 12756 (DIN 24960). FREF types are equipped with a short built mechanical seal. The mechanical seal is almost leakproof. Besides, it is maintenance-free.

When air is aspirated, the mating faces of the mechanical seal are hardly cooled or lubricated by the liquid handled. To ensure adequate lubrication, the intermediate cover is provided with a chamber, which must be filled with a lubricant (e.g. oil). This liquid must not attack the liquid handled nor the mechanical seal.

**2.10 Materials**

Fre-Flow pumps are available in the following materials :

- all cast iron
- cast iron with bronze impeller
- cast iron with stainless steel impeller
- all bronze
- all stainless steel

The pump shaft is always made of stainless steel (with the exception of bearing group 4) and the bearing bracket, or lantern piece, of cast iron. There are a number of factors which can be decisive for the material selection. Corrosion resistance of the materials is the most common. One of the reasons to opt for a stainless steel pump is to avoid pollution of the liquid handled by the pump material. A bronze impeller is advisable for pumps which are frequently out of operation, to prevent the pump from getting jammed due to corrosion in the seal clearances around the impeller. Another reason to choose a bronze impeller is that the flow velocity and, consequently, corrosion, are highest here.

**2.11 Connections**

Pump size FRE 32-110, 40-110, 32-150 and 40-170 are standard provided with thread connection. Starting with pump size 50-125 a ISO 7005 PN16 flange connection can be provided. Pumps of bearing group 4 are provided with ISO 7005 PN10 flange connections.

All pumps are also available with flange connections to ISO 7005 PN20 (ASME B16.5 Class 150 lbs). With FRE 32-110, 40-110, 32-150 and 40-170 in bronze, connection pieces (flange and thread pipe) are made of stainless steel.

**2.12 Application area**

The application area globally looks as follows;

*Table 1: Application area.*

	Maximum value
Capacity	350 m <sup>3</sup> /h
Discharge head	80 m
System pressure	9 bar
Temperature	95 °C
Self-priming	up to 7 m
Viscosity	150 mPa.s

**2.13 Re-use**

The pump may only be used for other applications after prior consultation with SPXFLOW or your supplier. Since the lastly pumped medium is not always known, the following instructions should be observed:

- 1 Flush the pump properly.
- 2 Make sure the flushing liquid is discharged safely (environment!)



**Take adequate precautions and use the appropriate personal protection means like rubber gloves and spectacles!**

**2.14 Scrapping**

If it has been decided to scrap a pump, the same flushing procedure as described for Re-use should be followed.



## 3 Installation

### 3.1 Safety

- Read this manual carefully prior to installation and commissioning. Non-observance of these instructions can result in serious damage to the pump and this will not be covered under the terms of our guarantee. Follow the instructions given step by step.
- Ensure that the pump can not be started if work has to be undertaken to the pump during installation and the rotating parts are insufficiently guarded.
- Depending on the design the pumps are suitable for liquids with a temperature of up to 95°C. When installing the pump unit to work at 65°C and above the user should ensure that appropriate protection measures and warnings are fitted to prevent contact with the hot pump parts.
- If there is danger of static electricity, the entire pump unit must be earthed.
- If the pumped liquid is harmful to men or the environment, take appropriate measures to drain the pump safely. Possible leakage liquid from the shaft seal should also be discharged safely.

### 3.2 Preservation

In order to prevent corrosion, the inside of the pump is treated with a preserving agent before leaving the factory.

Before commissioning the pump remove any preserving agents and flush the pump thoroughly with hot water.

### 3.3 Environment

- The foundation must be hard, level and flat.
- The area in which the pump is installed must be sufficiently ventilated. An ambient temperature or air humidity which is too high, or a dusty environment, can have a detrimental effect on the operation of the electric motor.
- There should be sufficient space around the pump unit to operate and if necessary repair it.
- Behind the cooling air inlet of the motor there must be a free area of at least 1/4 of the electric motor diameter, to ensure unobstructed air supply.
- In case the pump is provided with an isolation, special attention has to be paid To temperature limits of shaft seal and bearing.

## 3.4 Mounting

### 3.4.1 Installation of a pump unit

Pump and motor shafts of complete pump units are adjusted perfectly in line in the works.

- 1 In case of permanent arrangement place the base plate level on the foundation with the aid of shims.
- 2 Carefully tighten the nuts on the foundation bolts.
- 3 Check the alignment of pump and motor shafts and if necessary realign, see paragraph 3.4.3 "Alignment of the coupling".

### 3.4.2 Assembling a pump unit

If the pump and the electric motor still have to be assembled, do the following:

- 1 Fit both halves of the coupling to the pump shaft and the motor shaft respectively. For tightening moment of the set screw see paragraph 10.3.2 "Tightening moments set screw from coupling".
- 2 Place the pump on the base plate. Fix the pump to the base plate.
- 3 Place the electric motor on the base plate. Move the motor to obtain a gap of 3 mm between both coupling halves.
- 4 Place copper shims under the feet of the electric motor. Fix the electric motor to the base plate.
- 5 Align the coupling in accordance with the following instructions.

### 3.4.3 Alignment of the coupling

- 1 Place a ruler (A) on the coupling. Place or remove as many copper shims as is necessary to bring the electric motor to the correct height so that the straight edge touches both coupling halves over the entire length, see figure 4.

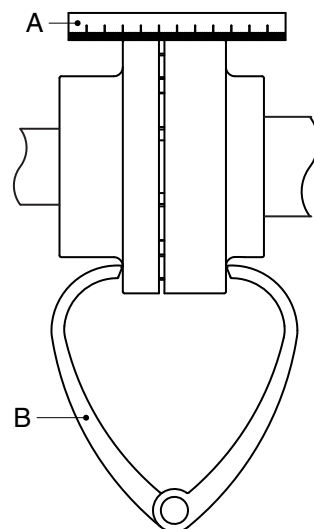

Figure 4: *Aligning the coupling by means of a ruler and a pair of outside calipers.*

- 2 Repeat the same check on both sides of the coupling at the height of the shaft. Move the electric motor so that the straight edge touches both coupling halves over the entire length.
- 3 Check the alignment once again using a pair of external callipers (B) at 2 diametrical opposite points on the sides of the coupling halves, see figure 4.

4 Fit the guard.

3.4.4 Tolerances for aligning the coupling

The maximum allowable tolerances for the alignment of the coupling halves are shown in Table 2. See also figure 5.

Table 2: Alignment tolerances

External diameter of coupling [mm]	V		Va <sub>max</sub> - Va <sub>min</sub> [mm]	Vr <sub>max</sub> [mm]
	min [mm]	max [mm]		
81-95	2	4	0,15	0,15
96-110	2	4	0,18	0,18
111-130	2	4	0,21	0,21
131-140	2	4	0,24	0,24
141-160	2	6	0,27	0,27
161-180	2	6	0,30	0,30
181-200	2	6	0,34	0,34
201-225	2	6	0,38	0,38

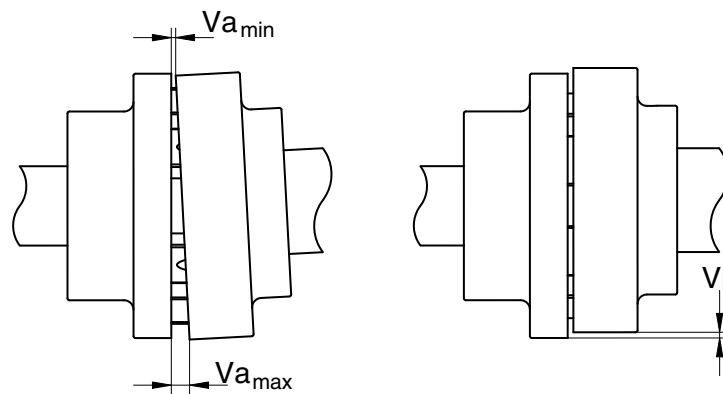

Figure 5: Alignment tolerances.

3.5 Installation of pumps with flanged-on motors

Pumps with flanged-on motors (FRES, FREF, FREM) can be mounted directly on a foundation, realignment of pump and motor shaft is not necessary.

3.6 Main piping connection

For connection of suction and discharge piping, there are different possibilities:

- 1 Screwed female connections
  - to 2" for cast iron pumps
  - to 1 1/2" for stainless steel pumps
- 2 Drilled holes in pump casing for connections ≥Rp50.

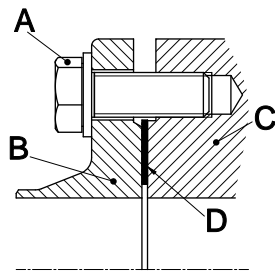

Figure 6: Connection main piping on pump casing.

<b>A</b>	bolt
<b>B</b>	flange of connected piping
<b>C</b>	pump casing
<b>D</b>	gasket

Table 3: Choose proper bolts according to the table below:

Pump size	Bolt	Pump size	Bolt
32-110	--	65-155	M16x40x4
32-150	--	80-140	M16x40x8
40-110	--	80-170	M16x40x8
40-170	--	80-210	M16x40x8
50-125b	M16x40x4	100-225b	M16x40x8
50-125	M16x40x4	100-225	M16x40x8
50-205	M16x40x4	100-250	M16x40x8
65-135b	M16x40x4	100-290b	M20x45x8
65-135	M16x40x4	100-290	M20x45x8
65-230	M16x40x4		

3 ASME connections for pump sizes 80

### 3.7 Piping

- The piping to the suction and delivery connections must fit exactly and must not be subject to stress during operation. The maximum allowable forces and moments on the pump flanges are stated in chapter 10 "Technical data".
- The passage of the suction pipe must be amply dimensioned. This pipe should be as short as possible.
- Sudden changes in the rate of flow can lead to high pressure impulses in the pump and the piping (water shock). Therefore, don't use quick-acting closing devices, valves etc.
- A foot valve in the suction line is not required for this selfpriming pump, unless this line is so voluminous or the operating conditions are so unfavourable that suction times longer than approximately 8 minutes have been calculated or measured.
- Avoid the entry of big or hard particles by installing a strainer.
- In case of a pump with a double mechanical seal (shaft sealing variant MD1), connect the flushing chamber to the flushing system. The pressure of the flushing system must be 1,5 bar higher than the pressure at the impeller hub!



### 3.8 Connection of the electric motor



***The electric motor must be connected to the mains by an approved electrician, according to the locally prevailing regulations of the electricity company.***

- Refer to the instruction manual belonging to the electric motor.
- If possible, fit a working switch as close as possible to the pump.

### 3.9 Combustion engine

#### 3.9.1 Safety

If the pump set is designed with a combustion engine, the manual for the engine should be included in the delivery. If the manual is missing we urgently request you to contact us immediately.

- Irrespective of the manual, the following points should be observed for all combustion engines:
- Comply with the local safety regulations.
- The exhaust of combustion gases must be screened off to prevent incidental contact.
- The starting device should automatically be disengaged after the engine has been started.
- The maximum speed of the engine set by us should **not** be changed.
- Before starting the engine check the oil level.

#### 3.9.2 Sense of rotation

The sense of rotation of combustion engine and pump is indicated by means of an arrow on the combustion engine and the pump casing. Verify whether the sense of rotation of the combustion engine is the same as that of the pump.



## 4 Commissioning

### 4.1 Inspection of the pump

- Check whether the pump shaft turns freely. Do this by turning the shaft end at the coupling a few times by hand.

### 4.2 Inspection of the motor

Pump driven by an electric motor:

- Check whether the fuses have been mounted.

Pump driven by a combustion engine:

- Check whether the room in which the engine is placed is well ventilated.
- Check whether the exhaust of the engine is not obstructed.
- Before starting the engine check the oil level.
- **Never run the engine in a closed room.**

### 4.3 Oil chamber



***The pumps are being delivered without any liquid in the oil chamber!***

- Fill the oil chamber with oil, see paragraph 10.1 "Oil chamber" for the appropriate type and quantity.
- If the liquid to be pumped may not come into contact with oil: fill the oil chamber with another suitable liquid.

### 4.4 Checking the sense of rotation



***Beware of possible non-screened rotating parts, when checking the sense of rotation!***

- 1 The sense of rotation of the pump is indicated by an arrow. Check whether the sense of rotation of the motor corresponds with that of the pump.
- 2 Let the motor run for only a short time and check the sense of rotation.
- 3 If the sense of rotation is **not** correct, alter the sense of rotation. See the instructions in the user manual belonging to the electric motor.
- 4 Fit the guard.

## 4.5 Start-up

Proceed as follows, both when the unit is put into operation for the first time and after the pump has been overhauled:

- 1 Fill the pump with the liquid to be handled through the filling plug at the pump front until the liquid starts to overflow.
- 2 Open the stop valve in the supply piping for flushing liquid, if the pump is supplied with a flushing system. When flushing a double mechanical seal (version MD1), the appropriate pressure of the flushing liquid must be set. This pressure must be 1,5 bar higher than the pressure at the impeller hub.
- 3 Open any pressure cut-off entirely. During the self-priming phase, it is necessary that the air escapes unobstructed and without any back pressure in the discharge pipe.
- 4 Start the pump.
- 5 As soon as the pump is under pressure, if necessary, adjust the delivery stop valve in order to obtain the desired the working pressure.



***Make sure that when a pump is running, rotating parts are always properly screened off by the guard!***

## 4.6 Pump in operation

When the pump is in operation, pay attention to the following:

- The pump should never run dry.
- The flushing liquid of a double mechanical seal (versions MD1) always must have the appropriate pressure set. This pressure must be 1,5 bar higher than the pressure at the impeller hub.
- Never use a stop valve in the suction line to control pump output. The stop valve should always be fully opened during operation.
- Check whether the absolute inlet pressure is sufficient, to prevent vaporization in the pump.
- Check whether the pressure difference between suction and delivery side corresponds with the specifications of the pump's duty point.

## 4.7 Noise

The noise production of a pump depends to a great extent on the operating conditions. The values stated in paragraph 10.6 "Noise data" are based on normal operation of the pump, driven by an electric motor. In case the pump is driven by a combustion engine, or in case it is used outside the normal operation area, as well as in case of cavitation, the noise level may exceed 85 dB(A). In that case precautions should be taken, like building a noise-barrier around the unit or wearing hearing protection.

## 5 Maintenance

### 5.1 Daily maintenance

Regularly check the outlet pressure.



**No water should get into the terminal box of the electric motor when the pump room is sprayed clean! Never spray water on hot pump parts! The sudden cooling down may cause them to burst and hot water may flow out!**



**Flawed maintenance will result in shorter lifespan, possible break down and in any event loss of warranty.**

### 5.2 Combustion engine



**Never top up with fuel while the motor is running!**

### 5.3 Mechanical seal

- A mechanical seal generally requires no maintenance, however, it should never be allowed to run dry. So the oil chamber behind the mechanical seal must always be filled with a lubricating liquid which will not attack the liquid to be pumped nor the mechanical seal. See paragraph 10.1 "Oil chamber" for the appropriate oil type.
- Drain the oil or the liquid every 2000 hours of operation or once a year and replace it by fresh oil or liquid. For the recommended quantities see paragraph 10.1 "Oil chamber".



*Make sure the drained oil or liquid is discharged safely. See to it that it doesn't get into the environment.*

- If there are no problems it is not advisable to dismantle the seal. As the facing surfaces are running in on one another. Dismantling always means replacement of the mechanical seal. When the shaft seal is leaking it has to be replaced.



**If the mechanical seal should start to leak, the oil chamber will overflow via the hole in the oil filler cap and the pump must be immediately stopped to replace the mechanical seal!**

### 5.4 Double mechanical seal

Regularly check the pressure of the flushing liquid. This pressure must be **1,5 bar higher than the pressure at the impeller hub.**

## 5.5 Environmental influences

- Regularly clean the filter in the suction pipe or the suction strainer at the bottom of the suction pipe, as the inlet pressure may become too low if the filter or the suction strainer is fouled.
- If there is a risk that the pumped liquid expands during solidification or freezing, the pump has to be drained and, if necessary, flushed after it has been put out of service.
- If the pump is out of service for a long time, it has to be preserved.
- Check motor for accumulation of dust or dirt, which might influence motor temperature.

## 5.6 Noise

If a pump starts making noise, this may point to certain problems with the pump unit. A crackling noise can indicate cavitation or excessive motor noise can indicate deterioration of the bearings.

## 5.7 Motor

Check motor specifications for start-stop frequency.

## 5.8 Faults



***The pump, of which you want to determine the fault, may be hot or under pressure. Take the appropriate precautions first and protect yourself with the proper safety devices (safety goggles, gloves, protective clothing)!***

To determine the source of the malfunctioning of the pump, proceed as follows:

- 1 Switch off the power supply to the pump unit. Lock the working switch with a padlock or remove the fuse. In case of a combustion engine: switch off the engine and close the fuel supply to the engine.
- 2 Close the stop valves.
- 3 Determine the nature of the fault.
- 4 Try to determine the cause of the fault with chapter 6 "Problem solving" and take the appropriate measures or contact your installer.

## 6 Problem solving

Faults in a pump installation can have various causes. The fault may not be in the pump, it may also be caused by the pipe system or the operating conditions. Firstly, always check that installation has been executed in accordance with the instructions in this manual and that the operating conditions still correspond with the specifications for which the pump was purchased.

In general, breakdowns in a pump installation are attributable to the following causes:

- Faults with the pump.
- Breakdowns or faults in the pipe system.
- Faults due to incorrect installation or commissioning.
- Faults due to incorrect choice of pump.

A number of the most frequently occurring failures as well as their possible causes are shown in the table below.

*Table 4: Most frequently occurring failures.*

<b>Most common faults</b>	<b>Possible causes, see Table 5.</b>
Pump delivers no liquid	1, 2, 3, 4, 5
Pump has insufficient volume flow	4, 5, 7, 8, 12, 17, 31
Pump has insufficient head	1, 5, 8, 9, 11, 17, 31
Motor is overloaded	8, 10, 11, 12, 13, 17, 22
Pump vibrates or is noisy	3, 4, 7, 8, 9, 14, 15, 16, 17, 18, 19, 20, 23
Bearings wear too much or become hot	15, 18, 21, 22, 23
Motor is running hot	8, 13, 24
Pump got stuck	2, 6, 17, 22
Irregular delivery	4, 7, 9, 14
Pump does not prime	1, 2, 5, 7
Pump has higher power consumption than normal	1, 8, 10, 13, 15, 16, 18, 20, 21, 24, 25, 27, 28, 32
Pump has lower power consumption than normal	1, 8, 13, 14, 23, 24, 25, 26, 29, 31
Mechanical seal have to be replaced to often	15, 18, 21, 28, 30, 31, 32, 33

Table 5: Possible causes of pump failures.

	Possible causes
1	Wrong sense of rotation
2	Pump not filled with liquid
3	Inlet or suction pipe insufficiently submerged
4	NPSH available too low
5	Pump not up to rated speed
6	Foreign particles in the pump
7	Air leak in the suction pipe
8	Liquid viscosity differs from the calculated liquid viscosity
9	Gas or air coming from the liquid
10	Speed too high
11	Total head lower than rated
12	Total head higher than rated
13	Liquid density differs from the calculated liquid density
14	Obstruction in the piping
15	Pump and motor not well aligned
16	Bearings faulty or worn out
17	Impeller blocked or damaged
18	Bent shaft
19	Improper location of discharge valve
20	Foundation not rigid
21	The bearings have been mounted wrongly
22	Vibration
23	Speed too low
24	Pump does not operate at the right duty point
25	Pump operates when the liquid flow is too low
26	Obstruction in impeller or pump casing
27	Dragging of rotating part
28	Imbalance in rotating parts (for instance: impeller or coupling)
29	Casing wear ring or wear plate faulty or worn out
30	Running faces of the mechanical seal are damaged
31	Mechanical seal has been mounted wrongly
32	Mechanical seal is not suitable for the operation circumstances
33	Liquid in oil chamber of the mechanical seal polluted



# 7 Disassembly and assembly

## 7.1 Precautionary measures



**Take adequate measures to avoid that the motor is started while you are working on the pump. This is especially important for electric motors with remote control:**

- Switch the operating switch near the pump (if available) to "OFF".
- Switch off the pump switch on the switchboard.
- If necessary remove the fuses.
- Hang a danger board near the switchboard cabinet.

## 7.2 Special tools

Assembly and disassembly work requires no special tools. However, such tools can make certain jobs easier, for instance replacing the shaft seal. If such is the case it will be indicated in the text.

## 7.3 Draining



**Make sure no liquid or oil gets into the environment!**

### 7.3.1 Liquid draining

Before starting any disassembly the pump should be drained.

- 1 If necessary, close the valves in the suction and delivery pipe and in the flushing or cooling supply lines to the shaft seal.
- 2 Remove the drain plug (0310) or cleaning cover (0370).
- 3 If harmful liquids are pumped wear protective gloves, shoes, glasses, etc., and thoroughly flush the pump.
- 4 Refit the drain plug or cleaning cover.



**If possible, wear protective gloves. Regular contact with oil products may result in allergic reactions.**

## 7.4 Constructive variants

The pumps can be supplied in various constructive variants. Each variant has a code which is stated in the type identification on the name plate on the pump. See paragraph 2.2 "Type code" for further explanation about the type identification.

## 7.5 Back-Pull-Out system

The pumps are designed with a Back-Pull-Out system. This means that almost the whole pump can be dismantled without having to detach the suction and delivery piping. The motor has to be removed from the foundation before disassembly.

### 7.5.1 Disassembling the guard

- 1 Loosen bolts (0960). See figure 9.
- 2 Remove both jackets (0270). See figure 7.

### 7.5.2 Disassembly Back Pull Out-unit

- 1 Unscrew bolts (0940) and remove the assembly plate (0275) from the bearing bracket (2100). See figure 10.
- 2 Remove the electric motor.
- 3 If provided with a Plan 11 on the shaft sealing: Unscrew screw joints (1410) and (1450) and remove the by-pass line (1420).
- 4 Remove the Allen screws (0800).
- 5 Pull the entire bearing bracket (2100) off the pump casing. The entire bearing bracket of large pumps is very heavy. Support it with a beam or hang it in a pulley sling.
- 6 Remove the coupling half from the pump shaft and remove the coupling key (2210).

### 7.5.3 Assembly Back Pull Out-unit

- 1 Fit a new gasket (0300) into the pump casing and fit the entire bearing bracket back into the pump casing. Tighten the Allen screws (0800) crosswise.
- 2 If provided with a Plan 11 on the shaft sealing: Fit the by-pass line (1420) and tighten screw joints (1410) and (1450).
- 3 Fit the assembly plate (0275) to the bearing bracket (2100) with bolts (0940). See figure 10.
- 4 Fit the coupling key (2210) and fit the coupling half onto the pump shaft.
- 5 Place the motor back in its place.
- 6 Check the alignment of pump and motor shaft, see paragraph 3.4.3 "Alignment of the coupling". If necessary, realign.

### 7.5.4 Assembling the guard

- 1 Fit the jacket (0270) at motor side. The annular groove must be located at motor side.

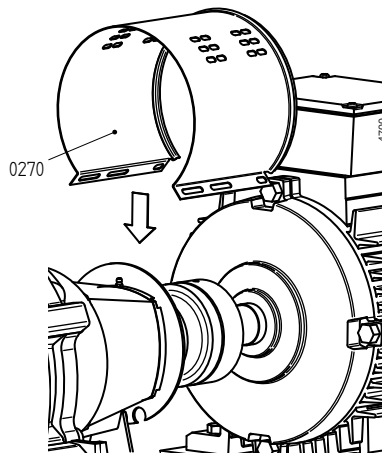

Figure 7: Fitting the jacket at motor side.

- Place the assembly plate (0280) over the motor shaft and fit it into the annular groove of the jacket.

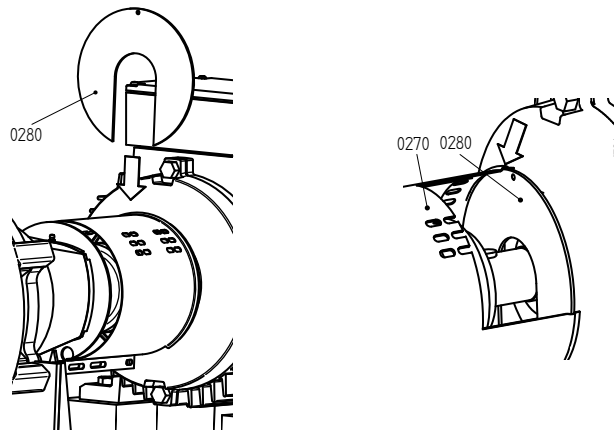

Figure 8: Fitting the assembly plate at motor side.

- Close the jacket and fit bolt (0960). See figure 9.

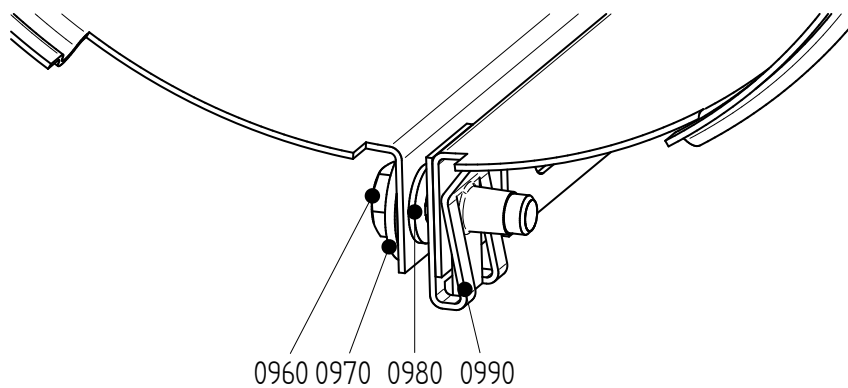

Figure 9: Fitting jacket.

- Mount the jacket (0270) at pump side. Place it over the present jacket at motor side. The annular groove must be located at pump side.

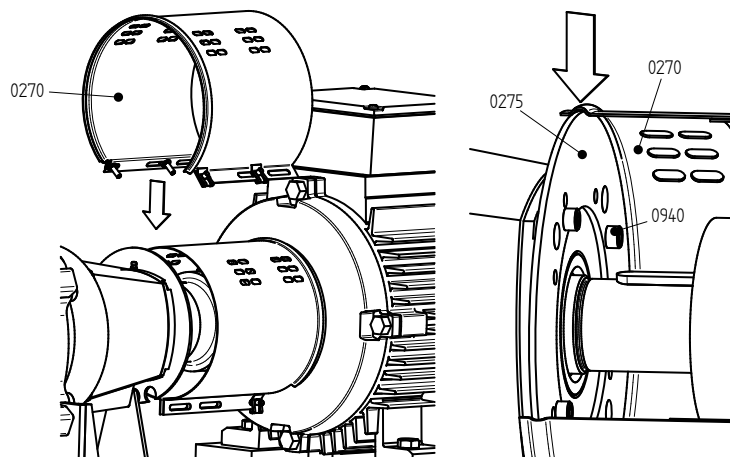

Figure 10: Fitting the jacket at pump side.

- Close the jacket and fit bolt (0960). See figure 9.

- 6 Slide the jacket at motor side towards the motor as far as possible. Fix both jackets with bolt (0960).

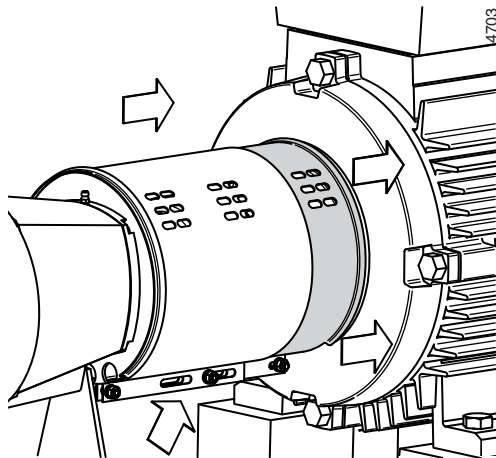

Figure 11: Adjusting the jacket at motor side.

## 7.6 Replacing the impeller and the wear ring

The clearance between the half open impeller and the wear plate may be 0,3 mm minimum and 0,6 mm maximum. If there is a decline in the performance characteristics of the pump this can be an indication of wear of the impeller and in the wear plate. To check this the pump must be dismantled in order to measure the clearance between the impeller and the wear plate.

### 7.6.1 Measuring clearance between impeller and wear plate, FRE bearing group 1

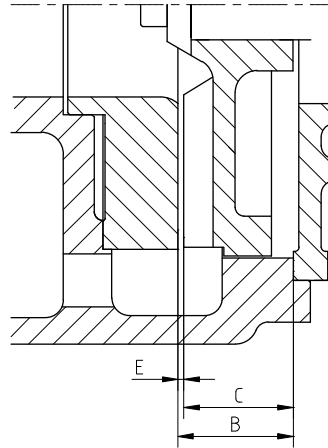

Figure 12: Clearance between impeller and wear plate, FRE bearing group 1.

- 1 Remove the Back Pull Out-unit, see paragraph 7.5.2 "Disassembly Back Pull Out-unit".
- 2 Measure the distance B between wear plate and pump casing, see figure 12.
- 3 Measure the distance C between impeller and intermediate cover, see figure 12.
- 4 Calculate the size of the shim (0220) to be fitted, using formula:  $E = B - C$ .

!

**E should be between minimum 0,3 mm and maximum 0,6 mm**

!

**If the calculated shim thickness exceeds 0,6 mm, impeller and wear plate must be replaced!**

## 7.6.2 Measuring clearance between impeller and wear plate, other bearing groups

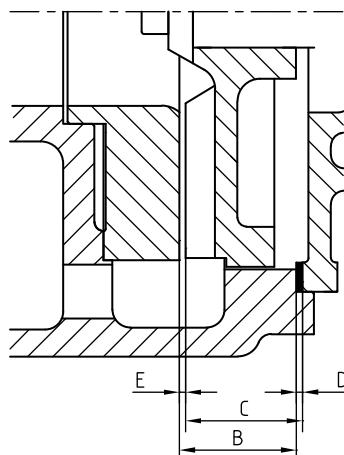

Figure 13: Clearance between impeller and wear plate.

- 1 Remove the Back Pull Out-unit, see paragraph 7.5.2 "Disassembly Back Pull Out-unit".
- 2 Remove the gasket (0300) and clean the edges of pump casing and intermediate cover.
- 3 Measure the distance B between wear plate and pump casing, see figure 13.
- 4 Measure the distance C between impeller and intermediate cover, see figure 13.
- 5 Find the appropriate gasket thickness D in the table below.
- 6 Calculate the size of the clearance E, using formula:  $E = B - C + D$
- 7 In case the clearance, due to wearing, has increased more than the maximum permitted value, the impeller and the wear plate should be replaced.

➤ For FRES or FREM it may be useful to check distance A, see paragraph 7.9.2 "Adjusting the impeller" or paragraph 7.11.2 "Adjusting the impeller" : wrong adjustment of the impeller can also be a cause of too much clearance.

gasket thickness [mm]		
0,25	0,3	0,5
80-170	50-125	80-210
100-225	50-125b	100-250
100-225b	65-135	150-290
	65-135b	150-290b
	65-155	
	80-140	

## 7.6.3 Disassembly of the impeller, bearing bracket 1

- 1 Remove the Back Pull Out-unit, see paragraph 7.5.2 "Disassembly Back Pull Out-unit"
- 2 Disassemble the impeller bolt (1820) and spring washer (1825).
- 3 Pull the impeller (0120) off the pump shaft, using a proper puller.
- 4 Remove the tolerance ring (1880).

- 7.6.4 Assembly of the impeller, bearing bracket 1
- 1 Place the tolerance ring (1880) into the shaft recess of the pump shaft (2200).
  - 2 For bronze and stainless steel pumps the tolerance ring must be isolated from the liquid. In order to do this apply Loctite 572 on the impeller stop face (0120), the shaft end and the rearmost part of the tolerance ring
  - 3 Push the impeller over the tolerance ring onto the shaft. **Make sure its position is square with the shaft!**
  - 4 Put a drop of Loctite 243 on the thread and mount the impeller bolt and spring washer (1825). See chapter 10 "Technical data" for the correct fastening moment.
- 7.6.5 Disassembly of the impeller, other bearing brackets
- 1 Remove the Back Pull Out-unit, see paragraph 7.5.2 "Disassembly Back Pull Out-unit".
  - 2 Bearing bracket 4: Tap the lips of the locking ring (1825) straight.
  - 3 Disassemble the impeller nut or the impeller bolt (1820).
  - 4 Bearing brackets 2 and 3: Remove the washer (1830).
  - 5 Pull the impeller (0120) off the pump shaft, using a proper puller.
  - 6 Remove the impeller nut (1860) from the pump shaft.
- 7.6.6 Assembly of the impeller, other bearing brackets
- 1 Place the impeller key (1860) into the key way of the pump shaft (2200).
  - 2 Slide the impeller onto the pump shaft.
  - 3 Bearing brackets 2 and 3: Fit the washer (1830).
  - 4 Bearing bracket 4: Fit the locking ring (1825).
  - 5 Degrease the thread of the pump shaft and impeller nut (1820) or impeller bolt (1820).
  - 6 Put a drop of Loctite 243 on the thread and mount the impeller nut or impeller bolt. See chapter 10 "Technical data" for the correct fastening moment.
  - 7 Bearing bracket 4: Tap the edges of the locking ring (1825) into the recesses of the pump shaft and the impeller nut or the impeller bolt.
- 7.6.7 Disassembly of the wear plate
- After disassembly of the Back Pull Out unit the wear plate can be removed. The item numbers refer to figure 56.
- 1 Loosen the screws (0115).
  - 2 Remove the wear plate (0125) from the pump casing, including the possible cutting blade (0105), if the pump is provided with a cutting mechanism.
- 7.6.8 Assembly of the wear plate
- 1 Clean the edge of the pump casing where the wear plate has to be fitted.
  - 2 Fit the wear plate, including the possible cutting blade (0105), if the pump is provided with a cutting mechanism, in the pump casing. When doing this, make sure that it is not pushed out of alignment. Pay attention to the position of the holes.
  - 3 Tighten the wear plate with screws (0115). For this use Loctite 243 to lock the screws.

## 7.6.9 Disassembling the wear ring

For pump with a closed impeller the wear occurs between the impeller and the wear ring. This wear may not exceed 1,2 mm to the diameter.

After removing the Back-Pull-Out unit the wear ring can be removed. In most cases the ring has been fixed so tightly that it cannot be removed undamaged.

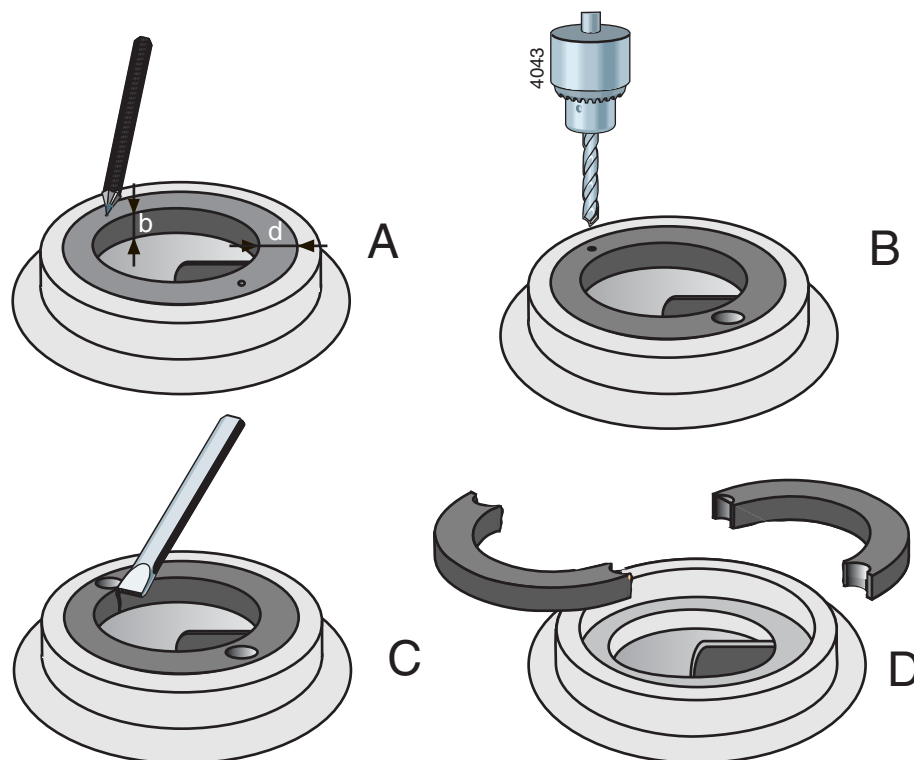

Figure 14: Removal of wear ring.

- 1 Measure the thickness (d) and the width (b) of the ring, see figure 14 A.
- 2 Make a centre hole in the middle of the edge of the ring at two opposite points, see figure 14 B.
- 3 Use a drill with a diameter just a little bit smaller than the thickness (d) of the ring and drill two holes in the ring, see figure 14 C. Don't drill deeper than the width (b) of the ring. Take care not to damage the fitting edge of the pump casing.
- 4 Use a chisel to cut the remaining part of the ring thickness. Now you can remove the ring in two parts from the pump casing, see figure 14 D.
- 5 Clean the pump casing and carefully remove all bore dust and metal splinters.

## 7.6.10 Assembling the wear ring

- 1 Clean and degrease the fitting edge of the pump casing where the wear ring is to be mounted.
- 2 Degrease the outer edge of the wear ring and put a few drops of Loctite 641 on it.
- 3 Fit the wear ring in the pump casing. **Take care it is not pushed out of alignment!**



## 7.7 Mechanical seal

### 7.7.1 Instructions for mounting a mechanical seal

➤ *First read the following instructions regarding the mounting of a mechanical seal. Follow these instructions closely when mounting a mechanical seal.*

- **Leave the assembly of a mechanical seal with PTFE (Teflon) covered O-rings to a specialist.** These rings are easily damaged during assembly.
- A mechanical seal is a fragile precision instrument. Leave the seal in its original packing until you are ready to fit it!
- Clean all receiving parts properly. Make sure your hands and working environment are clean!
- **Never touch the sliding surfaces with ones fingers!**
- Take care not to damage the seal during assembly. Never put the rings down on their sliding surfaces!

### 7.7.2 Disassembly of the mechanical seal MG12

The item numbers refer to figure 52.

- 1 Remove the impeller (0120), see paragraph 7.6.3 "Disassembly of the impeller, bearing bracket 1" and paragraph 7.6.5 "Disassembly of the impeller, other bearing brackets".
- 2 Remove the rotating part of the mechanical seal (1220) from the pump shaft.
- 3 Remove the intermediate cover (0110) from the bearing bracket (2100).
- 4 Remove the oil catcher (1235) and push the counter ring of the mechanical seal out of the intermediate cover.

### 7.7.3 Assembly of the mechanical seal MG12

- 1 Put some grease on the oil catcher (1235) and fit it into the intermediate cover (0110).
- 2 Put the intermediate cover flat down. Wet the seal chamber of the intermediate cover with some low-surface-tension water (add detergent) and fit the counter ring of the mechanical seal straight into it.
- 3 Fit a conical assembling bush onto the pump shaft or onto the stub shaft.
- 4 Fit the intermediate cover over the pump shaft, into the bearing bracket (2100).
- 5 Wet the pump shaft with some low-surface-tension water (add detergent). Do not use oil or grease! Feed the rotating part of the seal with a slight twist in clockwise direction onto the shaft until the rear end of the bellows is at equal level with the shaft shoulder. Apply pressure or tension during assembly via the rear end of the bellows only.
- 6 Remove the assembling bush.
- 7 Only for FRE 150-290 and 150-290b: Fit the distance ring (0370).
- 8 Fit the impeller and the other parts, see paragraph 7.6.4 "Assembly of the impeller, bearing bracket 1" and paragraph 7.6.6 "Assembly of the impeller, other bearing brackets".

## 7.7.4 Disassembly of the mechanical seal M7N

The item numbers refer to figure 52.

- 1 Remove the impeller (0120), see paragraph 7.6.3 "Disassembly of the impeller, bearing bracket 1" and paragraph 7.6.5 "Disassembly of the impeller, other bearing brackets".
- 2 Remove the rotating part of the mechanical seal (1220) from the pump shaft.
- 3 Remove the intermediate cover (0110) from the bearing bracket (2100).
- 4 Remove the oil catcher (1235) and push the counter ring of the mechanical seal out of the intermediate cover.

## 7.7.5 Assembly of the mechanical seal M7N

- 1 Put some grease on the oil catcher (1235) and fit it into the intermediate cover (0110).
- 2 Put the intermediate cover flat down. Put some glycerine or silicon spray into the seal compartment of the intermediate cover and press the counter ring of the mechanical seal straight into it. The opening in the counter ring must correspond to the position of the locking pin (1270), otherwise the counter ring will break!
- 3 Fit a conical assembling bush onto the pump shaft or onto the stub shaft.
- 4 Fit the intermediate cover over the pump shaft, into the bearing bracket (2100).
- 5 Slide the rotating part of the mechanical seal onto the pump shaft. Put some glycerine or silicon spray on the O-ring to prevent it from rolling on the shaft sleeve.
- 6 Adjust the rotating part of the mechanical seal to distance X (see figure 15 and corresponding table) and lock it by fixing the set screw (1220).
- 7 Remove the assembling bush.
- 8 Fit the impeller and the other parts, see paragraph 7.6.4 "Assembly of the impeller, bearing bracket 1" and paragraph 7.6.6 "Assembly of the impeller, other bearing brackets".

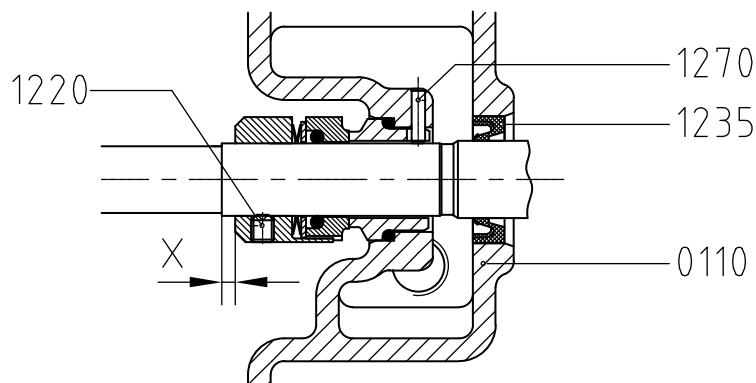

Figure 15: Adjusting the mechanical seal M7N.

Shaft $\varnothing$	16	25	30	40	50
X	23	3	7	0	10,8

### 7.7.6 Disassembly of double mechanical seal MD1

The item numbers refer to figure 55.

- 1 Disassemble the impeller (0120), see paragraph 7.6.3 "Disassembly of the impeller, bearing bracket 1" and paragraph 7.6.5 "Disassembly of the impeller, other bearing brackets".
- 2 Remove bolts (1800) and slide the mechanical seal cover (1230) backward.
- 3 Mark the position of the intermediate cover (0110) in relation to the bearing bracket (2100). Knock the intermediate cover loose and remove it.
- 4 Unscrew both set screws (1250) and remove the shaft sleeve (1200) from the pump shaft.
- 5 Unscrew the set screw and remove the rotating parts of the mechanical seal (1220) from the pump shaft.
- 6 Unscrew the set screw and remove the rotating parts of the mechanical seal (1225) from the shaft sleeve.
- 7 Push the counter ring of mechanical seal (1225) out of the intermediate cover.
- 8 Remove the mechanical seal cover from the pump shaft and push the counter ring of mechanical seal (1220) out. Remove the O-ring (1300).

### 7.7.7 Assembly double mechanical seal MD1

- 1 Put the mechanical seal cover (1230) flat down. Put some glycerine or silicon spray into the seal compartment and press the counter ring of the mechanical seal (1220) straight into it. The opening in the counter ring must correspond to the position of the locking pin (1260), otherwise the counter ring will break!
- 2 Put the intermediate cover (0110) flat down. Put some glycerine or silicon spray into the seal compartment and press the counter ring of the mechanical seal (1225) straight into it. The opening in the counter ring must correspond to the position of the locking pin (1270), otherwise the counter ring will break!
- 3 Fit the O-ring (1320) into the shaft sleeve. Fit the rotating part of the mechanical seal (1225) onto the shaft sleeve. Tighten the set screw.
- 4 Place the bearing bracket with the shaft in upright position.
- 5 Fit the mechanical seal cover onto the pump shaft. Fit the O-ring (1300).
- 6 Fit the rotating part of the mechanical seal (1220) onto the shaft. Adjust the rotating part of the mechanical seal to distance X1 from figure 16 and corresponding table. Lock it by fixing the set screw.

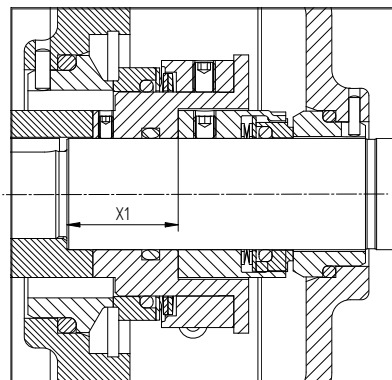

Figure 16: Adjusting the mechanical seal MD1.

Shaft ø	16	25	30
X	43	18,8	30

- 7 Fit the shaft sleeve (1200) with the rotating part of the shaft sealing (1225) onto the shaft.
- 8 Fit the intermediate cover in the proper position into the centring rim of the bearing bracket (2100).
- 9 Fit the mechanical seal cover (1230) to the intermediate cover. Ensure it is fitted in the right position, with regard to the connections. Tighten bolts (1800) crosswise. The cover may not be placed oblique.
- 10 Fit the impeller and other parts, see paragraph 7.6.6 "Assembly of the impeller, other bearing brackets".

## 7.8 Bearing

### 7.8.1 Instructions for assembly and disassembly of bearings

- *First read the following instructions regarding assembly and disassembly. Follow these instructions closely when assembling and disassembling bearings.*

#### **Disassembly:**

- Use a **proper puller** to remove the bearings from the pump shaft.
- If no proper puller is available, carefully knock at the inner raceway of the bearing. Use an ordinary hammer and a mild steel drift for this.  
**Never knock at the bearing with a hammer!**

#### **Assembly:**

- Make sure your working place is clean.
- Leave the bearings in their original packing as long as possible.
- Make sure the pump shaft and the bearing seats do have a smooth surface, free of burrs.
- Slightly oil the pump shaft and the other relevant parts before assembly.
- **Preheat the bearings to 110°C** before mounting them on the pump shaft.
- If preheating is not possible: knock the bearing onto the pump shaft. **Never knock at the bearing directly!** Use a mounting bush positioned against the inner raceway of the bearing and a normal hammer (a soft hammer might loose some splinters which could damage the bearing).

### 7.8.2 Disassembly of the bearings FRE - bearing bracket 1

The item numbers refer to figure 44.

- 1 Disassemble the impeller and the shaft seal, see paragraph 7.6.3 "Disassembly of the impeller, bearing bracket 1" and paragraph 7.7.2 "Disassembly of the mechanical seal MG12".
- 2 Disassemble the laminated seal (2165).
- 3 Remove the bearing cover (2115).
- 4 Disassemble the inner circlip (2305) and remove the adjustment ring (2330).
- 5 Use a plastic hammer and knock on the impeller side of the shaft with the bearings as to remove it from the back of the bearing bracket.
- 6 Use a proper puller to remove the bearings from the pump shaft.
- 7 Disassemble the inner circlip (2300).

### 7.8.3 Assembly of the bearings FRE - bearing bracket 1

- 1 Mount the preheated bearing (2250) carefully on the pump shaft (2200) at impeller side and push it firmly against the shaft shoulder. **Let the bearing cool down!**
- 2 Mount the preheated bearing (2260) carefully on the pump shaft at drive side and push it firmly against the shaft shoulder. **Let the bearing cool down!**
- 3 Fit the inner circlip (2300) into the bearing bore at impeller side.
- 4 Push the shaft with both bearings through the bore at the back of the bearing bracket until the bearing at impeller side touches the inner circlip.
- 5 Place the adjustment ring (2330) onto the bearing at drive side and fit the inner circlip (2305), with its teeth facing the adjustment ring.
- 6 Mount the bearing cover (2115) at drive side and protect the bearing at impeller side by mounting the laminated seal (2165).
- 7 Mount the shaft seal and the impeller, see paragraph 7.7.3 "Assembly of the mechanical seal MG12" and paragraph 7.6.4 "Assembly of the impeller, bearing bracket 1".

### 7.8.4 Disassembly of the bearings FRE - bearing bracket 2

The item numbers refer to figure 45.

- 1 Disassemble the impeller and the shaft seal, see paragraph 7.6.5 "Disassembly of the impeller, other bearing brackets" and paragraph 7.7.2 "Disassembly of the mechanical seal MG12".
- 2 Disassemble the laminated seal (2165).
- 3 Remove the bearing cover (2115).
- 4 Disassemble the inner circlip (2305) and remove the adjustment ring (2330).
- 5 Use a plastic hammer and knock on the impeller side of the shaft with the bearings as to remove it from the back of the bearing bracket.
- 6 Use a proper puller to remove the bearings from the pump shaft. Remove the rubber closure ring (2390).
- 7 Remove the adjustment ring (2335) from the bearing bore.
- 8 Disassemble the inner circlip (2300).

### 7.8.5 Assembly of the bearings FRE - bearing bracket 2

- 1 Mount the rubber closure ring (2390) onto the pump shaft at impeller side with its largest part facing the impeller.
- 2 Mount the preheated bearing (2250) carefully on the pump shaft (2200) at impeller side and push it firmly against the rubber closure ring. **Let the bearing cool down!**
- 3 Mount the preheated bearing (2260) carefully on the pump shaft at drive side and push it firmly against the shaft shoulder. **Let the bearing cool down!**
- 4 Pull the rubber closure ring gently aside and apply a small amount of grease at both sides of the angular contact bearing (2250). Push the closure ring back in its correct position.
- 5 Fit the inner circlip (2300) into the bearing bore at impeller side.
- 6 Place the adjustment ring (2335) onto it.
- 7 Push the shaft with both bearings through the bore at the back of the bearing bracket until the bearing at impeller side touches the inner circlip. The adjustment ring is now locked between the bearing and the inner circlip.
- 8 Place the adjustment ring (2330) onto the bearing at drive side and fit the inner circlip (2305), with its teeth facing the adjustment ring.

- 9 Mount the bearing cover (2115) at drive side and protect the bearing at impeller side by mounting the laminated seal (2165).
- 10 Mount the shaft seal and the impeller, see paragraph 7.7.3 "Assembly of the mechanical seal MG12" and paragraph 7.6.6 "Assembly of the impeller, other bearing brackets".

## 7.8.6 Disassembly of the bearings FRE - bearing bracket 3

The item numbers refer to figure 46.

- 1 Disassemble the impeller and the shaft seal, see paragraph 7.6.5 "Disassembly of the impeller, other bearing brackets" and paragraph 7.7.2 "Disassembly of the mechanical seal MG12".
- 2 Disassemble the laminated seal (2165).
- 3 Remove the bearing cover (2115).
- 4 Disassemble the inner circlip (2300) at drive side and remove the shim ring (2331), the waved ring (2355) and the other shim ring (2330).
- 5 Use a plastic hammer and knock on the impeller side of the shaft with the bearings as to remove it from the back of the bearing bracket.
- 6 Use a proper puller to remove the bearings from the pump shaft. Remove both the rubber closure rings (2390).
- 7 Remove the adjustment ring (2335) from the bearing bore.
- 8 Disassemble the inner circlip (2300).

## 7.8.7 Assembly of the bearings FRE - bearing bracket 3

- 1 Mount both the rubber closure rings (2390) onto the pump shaft, its largest sides turned away from each other.

**!**

### **The bearing are to be mounted in X set-up!**

- 2 Mount the preheated bearing (2250) carefully on the pump shaft (2200) at impeller side and push it firmly against the shaft shoulder. **Let the bearing cool down!**
- 3 Mount the preheated bearing (2260) carefully on the pump shaft at drive side and push it firmly against the shaft shoulder. **Let the bearing cool down!**
- 4 Pull the rubber closure rings gently aside and apply a small amount of grease at both sides of the bearings. Push the closure rings back in their correct position.
- 5 Fit the inner circlip (2300) into the bearing bore at impeller side.
- 6 Place the adjustment ring (2335) onto it.
- 7 Push the shaft with both bearings through the bore at the back of the bearing bracket until the bearing at impeller side touches the inner circlip. The adjustment ring is now locked between the bearing and the inner circlip.
- 8 Place the shim ring (2330) onto the bearing at drive side and the waved ring (2355) and the shim ring (2331).
- 9 Fit the inner circlip (2300) at drive side.
- 10 Mount the bearing cover (2115) at drive side and protect the bearing at impeller side by mounting the laminated seal (2165).
- 11 Mount the shaft seal and the impeller, see paragraph 7.7.3 "Assembly of the mechanical seal MG12" and paragraph 7.6.6 "Assembly of the impeller, other bearing brackets".

### 7.8.8 Disassembly of the bearings FRE 80-210 and 100-250

The item numbers refer to figure 47.

- 1 Disassemble the impeller and the shaft seal, see paragraph 7.6.5 "Disassembly of the impeller, other bearing brackets" and paragraph 7.7.2 "Disassembly of the mechanical seal MG12".
- 2 Disassemble the lip seal (2180).
- 3 Disassemble the Allen screws (2815) and remove the bearing cover (2115).
- 4 Disassemble the inner circlip (2305) and remove the adjustment ring (2330), if present.
- 5 Use a plastic hammer and knock on the impeller side of the shaft with the bearings as to remove it from the back of the bearing bracket.
- 6 Use a proper puller to remove the bearings from the pump shaft.
- 7 Remove the Nilos ring (2310).
- 8 Remove both outer circlips (2340) and (2345).
- 9 Remove the Nilos ring (2315) and the adjustment ring (2335), if present, from the bearing bore.
- 10 Disassemble the inner circlip (2300).

### 7.8.9 Assembly of the bearings FRE 80-210 and 100-250

- 1 Fit the outer circlips (2340) and (2345).
- 2 Place the Nilos ring (2310) over the pump shaft (2200) at impeller side.
- 3 Mount the preheated bearing (2250) carefully on the pump shaft at impeller side, with the largest part of the inner ring facing the outer circlip and push it firmly against the outer circlip. **Let the bearing cool down!** The Nilos ring (2310) is now locked between the bearing and the outer circlip.
- 4 Mount the preheated bearing (2260) carefully on the pump shaft (2200) at drive side and push it firmly against the outer circlip. **Let the bearing cool down!**
- 5 Pull the rubber closure ring gently aside and apply a small amount of grease at both sides of the angular contact bearing (2250). Push the closure ring back in its correct position.
- 6 Fit the inner circlip (2300).
- 7 *For FRE 100-250 only:* Place the adjustment ring (2335) onto the inner circlip.
- 8 Place the Nilos ring (2315).
- 9 Push the shaft with both bearings through the bore at the back of the bearing bracket until the bearing at impeller side touches the inner circlip. The adjustment ring, if present, and the Nilos ring are now locked up between the bearing and the inner circlip.
- 10 *For FRE 100-250 only:* Place the adjustment ring (2330).
- 11 Fit the inner circlip (2305).
- 12 Mount the bearing cover (2115) at drive side using Allen screws (2815).
- 13 Mount the lip seal (2180) at impeller side.
- 14 Mount the shaft seal and the impeller, see paragraph 7.7.3 "Assembly of the mechanical seal MG12" and paragraph 7.6.6 "Assembly of the impeller, other bearing brackets".

## 7.8.10 Disassembly of the bearings FRE 150-290b and 150-290

The item numbers refer to figure 48.

- 1 Disassemble the impeller and the shaft seal, see paragraph 7.6.5 "Disassembly of the impeller, other bearing brackets" and paragraph 7.7.2 "Disassembly of the mechanical seal MG12".
- 2 Disassemble the lip seal (2180).
- 3 Disassemble the Allen screws (2815) and remove the bearing cover (2115).
- 4 Disassemble the inner circlip (2305) and remove the adjustment ring (2330).
- 5 Use a plastic hammer and knock on the impeller side of the shaft with the bearings as to remove it from the back of the bearing bracket.
- 6 Use a proper puller to remove the bearings from the pump shaft.
- 7 Remove the Nilos ring (2310).
- 8 Remove the Nilos ring (2315) and the adjustment ring (2335) from the bearing bore.

## 7.8.11 Assembly of the bearings 150-290b and 150-290

- 1 Place the Nilos ring (2310) over the pump shaft (2200) at impeller side.
- 2 Mount the preheated bearing (2250) carefully on the pump shaft at impeller side, with the largest part of the inner ring facing the outer circlip and push it firmly against the shaft shoulder. **Let the bearing cool down!** The Nilos ring (2310) is now locked between the bearing and the shaft shoulder.
- 3 Mount the preheated bearing (2260) carefully on the pump shaft at drive side and push it firmly against the outer circlip. **Let the bearing cool down!**
- 4 Pull the rubber closure ring gently aside and apply a small amount of grease at both sides of the angular contact bearing (2250). Push the closure ring back in its correct position.
- 5 Place the adjustment ring (2335) into the bearing bore at impeller side.
- 6 Place the Nilos ring (2315).
- 7 Push the shaft with both bearings through the bore at the back of the bearing bracket until the bearing at impeller side touches the bearing seat. The adjustment ring, if present, and the Nilos ring are now locked up between the bearing and the bearing seat.
- 8 Place the adjustment ring (2330) and fit the inner circlip (2305).
- 9 Mount the bearing cover (2115) at drive side using Allen screws (2815).
- 10 Mount the lip seal (2180) at impeller side.
- 11 Mount the shaft seal and the impeller, see paragraph 7.7.3 "Assembly of the mechanical seal MG12" and paragraph 7.6.6 "Assembly of the impeller, other bearing brackets".



## 7.9 FRES

### 7.9.1 Assembly of the electric motor



**The electric motor must be provided with a fixed bearing.**

- 1 Check if the axial clearance of the motor shaft does not exceed 0,3 mm.
- 2 Place the motor vertically, support the shaft on fan side, so that it is pushed to motor flange side and the axial clearance is absorbed.
- 3 For motors up to and including IEC 112, remove the key from the shaft end**
- 4 Push the stub shaft (2200) over the shaft end.
- 5 Fit the 2 set screws (2280) into the sub shaft hub, using Loctite 243, till they are inside the keyway, but do not tighten the screws. **For motors of IEC 112 upwards fit only one set screw at the pump casing side**
- 6 Place the lantern piece (0250) on the motor, using the bolts (0850) and nuts (0900).

### 7.9.2 Adjusting the impeller

- 1 Fit the intermediate cover (0110), the mechanical seal (1220) and the impeller (0120).
- 2 Adjust the impeller to size **A** between the rear of the impeller and the intermediate cover. See figure 17 and Table 6 below. Preferably use 2 calibrated rulers.

Table 6:

Bearing bracket	A +/- 0,05
1	6
2	10
3	16,75

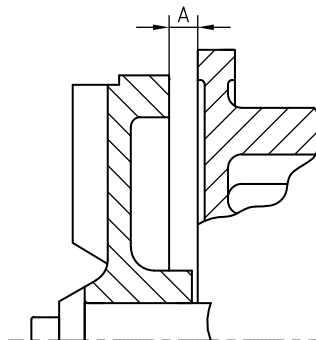

Figure 17: Adjusting the impeller FRES.

- 3 Push the rulers snugly against the impeller and tighten the set screws (2280).
- 4 For motors upwards of IEC 112, mark a drilling point on the motor shaft in the free tapped hole of the stub shaft, fit the second set screw, using Loctite 243. Properly tighten both set screws.

## 7.10 FREF

### 7.10.1 Assembly of the electric motor

- 1 Place the motor vertically, with the shaft pointing upwards.
- 2 Place the lantern piece (0250) on the motor, using the bolts (0850) and nuts (0900).

## 7.11 FREM

### 7.11.1 Assembly combustion engine

- 1 Check if the axial clearance of the motor shaft does not exceed 0,3 mm.
- 2 Place the combustion engine vertically, with the shaft pointing upwards.
- 3 Apply some **Loctite 648** on the motor shaft end. **Never use quick drying Loctite!**
- 4 Push the stub shaft (2200) over the motor shaft. Take care the hole for the set screw corresponds with the keyway of the motor shaft.
- 5 Fit the set screw (2280) using Loctite 243, but do not tighten the screw.
- 6 Place the lantern piece (0250) on the motor, using the bolts (0850) and nuts (0900).

### 7.11.2 Adjusting the impeller

- 1 Fit the intermediate cover (0110), the mechanical seal (1220) and the impeller (0120).
- 2 Adjust the impeller to size **A** between the rear of the impeller and the intermediate cover. See figure 18 and Table 7 below. Preferably use 2 calibrated rulers.

Table 7:

Bearing bracket	A +/- 0,05
1	6
2	10

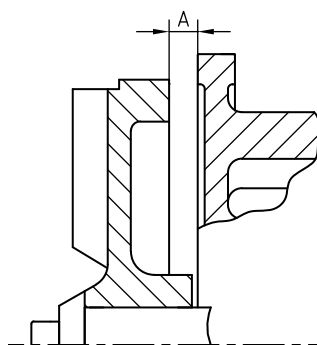

Figure 18: Adjusting the impeller FREM.

- 3 Push the rulers snugly against the impeller and tighten the set screw (2280).

# 8 Dimensions

## 8.1 FRE - bearing groups 1,2 and 3

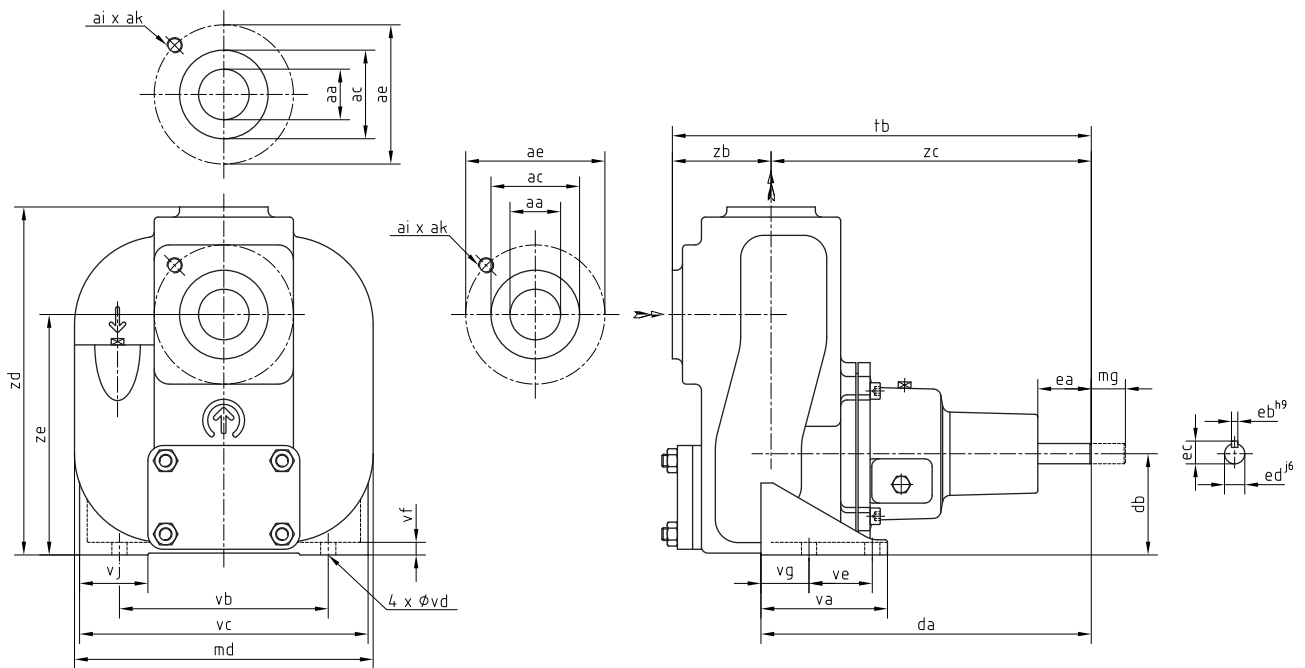

Figure 19: FRE - bearing groups 1, 2 and 3.

FRE	aa	ac	ae	ai	ak	da	db	ea	eb	ec	ed	md	mg
32-110	Rp 1¼	-	-	-	-	256	80	40	5	18	16	236	35
32-150	Rp 1¼	-	-	-	-	297	100	50	8	27	24	235	45
40-110	Rp 1½	-	-	-	-	261	80	40	5	18	16	244	35
40-170	Rp 1½	-	-	-	-	380	160	60	8	31	28	314	80
50-125b	Rp 2(*)	100	125	4	M16	311	100	50	8	27	24	280	45
50-125	Rp 2(*)	100	125	4	M16	311	100	50	8	27	24	280	45
50-205	Rp 2	100	125	4	M16	394	160	60	8	31	28	318	80
65-135b	65	120	145	4	M16	318	112	50	8	27	24	268	50
65-135	65	120	145	4	M16	318	112	50	8	27	24	268	50
65-155	65	120	145	4	M16	318	132	50	8	27	24	308	50
65-230	65	120	145	4	M16	400	160	60	8	31	28	368	80
80-140	80	135	160	8	M16	337	132	50	8	27	24	312	50
80-170	80	135	160	8	M16	416	160	60	8	31	28	368	80
100-225b	100	155	180	8	M16	457	200	60	8	31	28	452	100
100-225	100	155	180	8	M16	457	200	60	8	31	28	452	100

(\*) R6 : aa=50mm

aa ≥ 50 : ISO 7005 PN 16 connections

FRE	tb	va	vb	vc	vd	ve	vf	vg	vj	zb	zc	zd	ze	[kg]
32-110	321	100	165	228	12	50	10	38	54	73	248	270	185	20
32-150	362	91	190	240	12	40	12	36	75	73	289	300	205	30
40-110	331	100	165	228	12	50	10	38	54	78	253	275	190	22
40-170	448	111	222	292	14	50	15	46	91	78	370	394	285	60
50-125b	403	110	190	260	14	60	12	38	63	100	303	330	220	40
50-125	403	110	190	260	14	60	12	38	63	100	303	330	220	40
50-205	489	122	230	310	14	60	15	51	92	105	384	440	300	80
65-135b	417	116	190	260	14	60	12	41	75	107	310	365	252	45
65-135	417	116	190	260	14	60	12	41	75	107	310	365	252	45
65-155	417	112	212	292	14	70	12	27	83	107	310	395	282	52
65-230	505	128	250	356	14	60	15	53	108	115	390	475	325	90
80-140	455	136	212	292	14	80	12	41	79	126	329	410	282	62
80-170	533	143	250	360	14	80	15	48	115	127	406	470	340	100
100-225b	603	171	315	440	14	100	15	51	125	156	447	595	430	145
100-225	603	171	315	440	14	100	15	51	125	156	447	595	430	145

8.2 FRE - bearing group 4

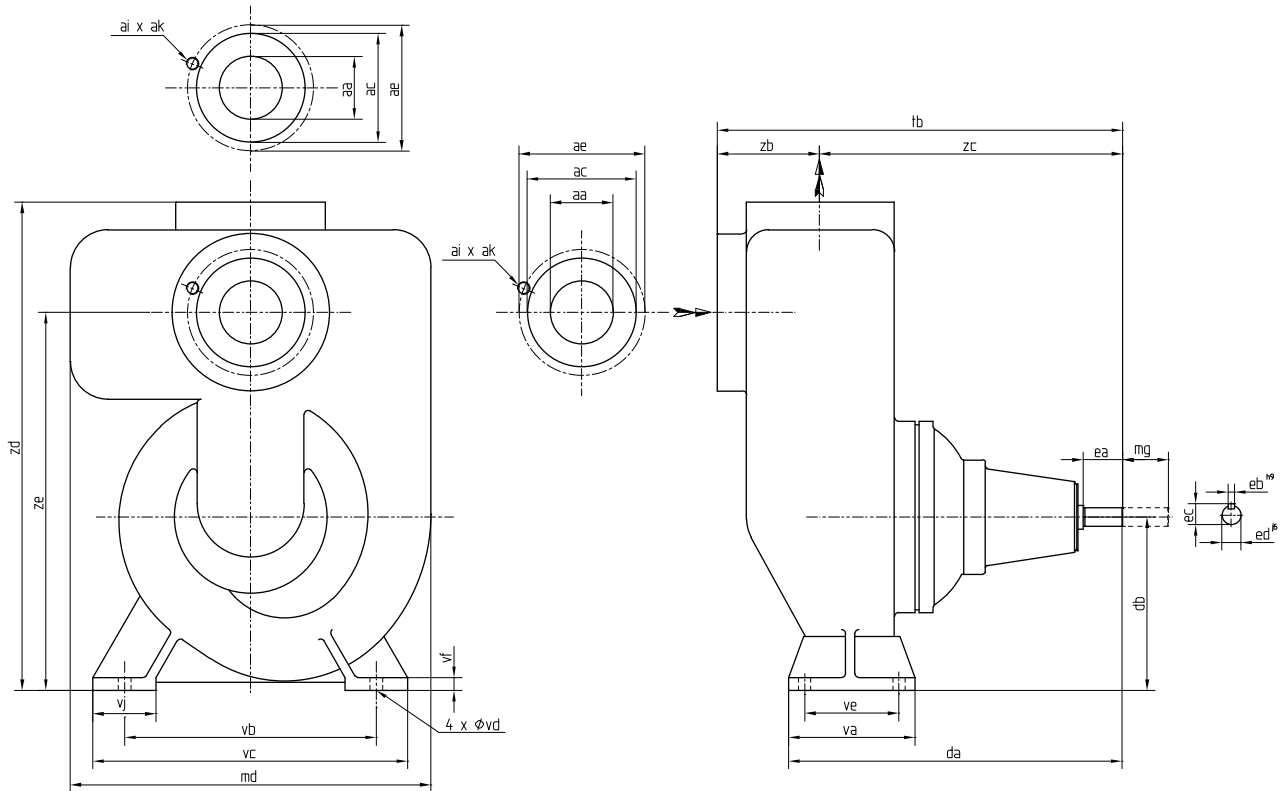

Figure 20: FRE - bearing group 4.

FRE	aa	ac	ae	ai	ak	da	db	ea	eb	ec	ed	md	mg
80-210	80	138	160	8	M16	424	220	50	8	27	24	458	90
100-250	100	158	180	8	M16	524	280	80	10	35	32	520	110
150-290b	150	212	240	8	M20	615	250	110	12	45	42	520	120
150-290	150	212	240	8	M20	615	250	110	12	45	42	520	120

ISO 7005 PN 16 connections

FRE	tb	va	vb	vc	vd	ve	vf	vj	zb	zc	zd	ze	[kg]
80-210	515	160	320	400	18	120	16	80	130	385	620	480	130
100-250	640	160	315	400	18	120	18	80	145	495	730	590	150
150-290b	768,5	200	400	490	22	150	22	95	185,5	583	715	540	270
150-290	768,5	200	400	490	22	150	22	95	185,5	583	715	540	270

## 8.3 FRE with ISO 7005 PN20 connections

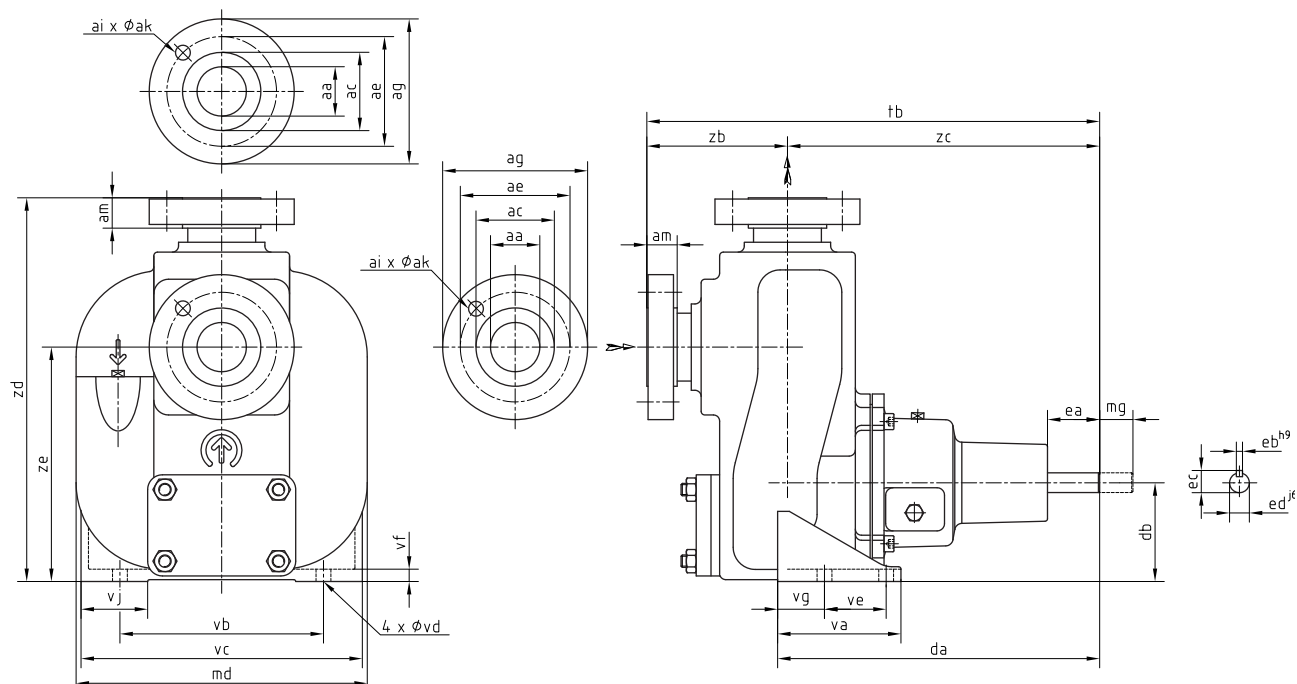

Figure 21: FRE with ISO 7005 PN20 connections.

FRE	aa	ac	ae	ag	ai	ak	am	da	db	ea	eb	ec	ed	md	mg
32-110	32	63,5	88,9	117,5	4	16	20,6	256	80	40	5	18	16	236	35
32-150	32	63,5	88,9	117,5	4	16	20,6	297	100	50	8	27	24	235	45
40-110	40	73	98,4	127	4	16	22,2	261	80	40	5	18	16	244	35
40-170	40	73	98,4	127	4	16	22,2	380	160	60	8	31	28	314	80

FRE	tb	va	vb	vc	vd	ve	vf	vg	vj	zb	zc	zd	ze	[kg]
32-110	356	100	165	228	12	50	10	38	54	108	248	305	185	23
32-150	397	91	190	240	12	40	12	36	75	108	289	335	205	33
40-110	366	100	165	228	12	50	10	38	54	113	253	310	190	26
40-170	483	111	222	292	14	50	15	46	91	113	370	429	285	64

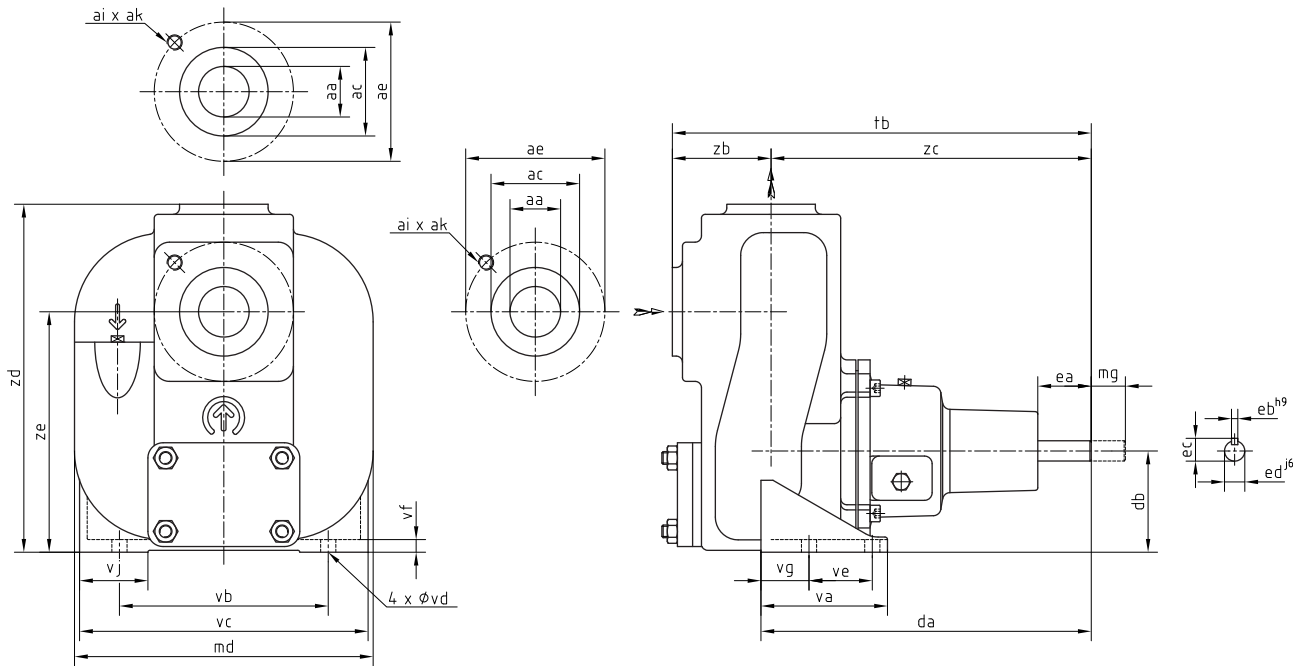

Figure 22: FRE with ISO 7005 PN20 connections.

FRE	aa	ac	ae	ai	ak	da	db	ea	eb	ec	ed	md	mg
50-125b	50	100	120,7(*)	4	M16	311	100	50	8	27	24	280	45
50-125	50	100	120,7(*)	4	M16	311	100	50	8	27	24	280	45
50-205	50	100	120,7(*)	4	M16	394	160	60	8	31	28	318	80
65-135b	65	120	139,7(*)	4	M16	318	112	50	8	27	24	268	50
65-135	65	120	139,7(*)	4	M16	318	112	50	8	27	24	268	50
65-155	65	120	139,7(*)	4	M16	318	132	50	8	27	24	308	50
65-230	65	120	139,7(*)	4	M16	400	160	60	8	31	28	368	80
100-225b	100	160	190,5	8	M16	457	200	60	8	31	28	452	100
100-225	100	160	190,5	8	M16	457	200	60	8	31	28	452	100

(\*) ae = according to PN20 + 0,2 mm

FRE	tb	va	vb	vc	vd	ve	vf	vg	vj	zb	zc	zd	ze	[kg]
50-125b	403	110	190	260	14	60	12	38	63	100	303	330	220	40
50-125	403	110	190	260	14	60	12	38	63	100	303	330	220	40
50-205	489	122	230	310	14	60	15	51	92	105	384	440	300	80
65-135b	417	116	190	260	14	60	12	41	75	107	310	365	252	45
65-135	417	116	190	260	14	60	12	41	75	107	310	365	252	45
65-155	417	112	212	292	14	70	12	27	83	107	310	395	282	52
65-230	505	128	250	356	14	60	15	53	108	115	390	475	325	90
100-225b	603	171	315	440	14	100	15	51	125	156	447	595	430	145
100-225	603	171	315	440	14	100	15	51	125	156	447	595	430	145

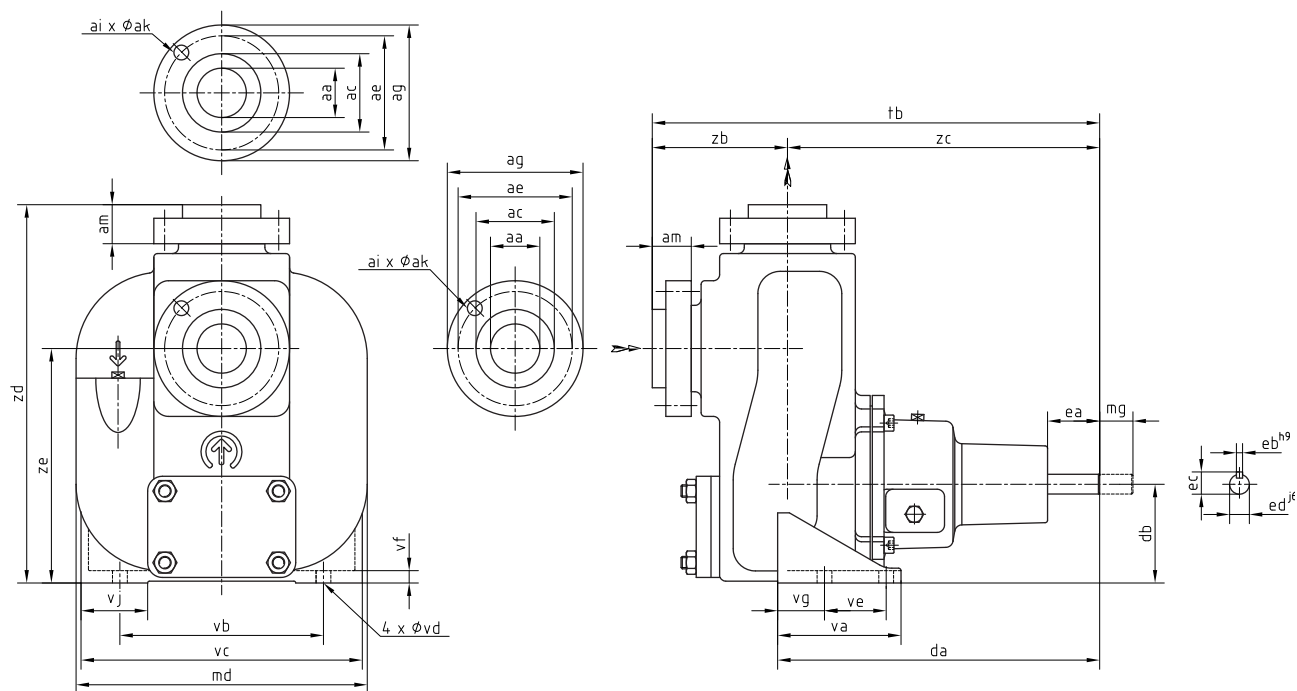

Figure 23: FRED with ISO 7005 PN20 connections.

FRE	aa	ac	ae	ag	ai	ak	am	da	db	ea	eb	ec	ed	md	mg
80-140	80	135	152,5	192	4	M16	40	337	132	50	8	27	24	312	50
80-170	80	135	152,5	192	4	M16	40	416	160	60	8	31	28	368	80

FRE	tb	va	vb	vc	vd	ve	vf	vg	vj	zb	zc	zd	ze	[kg]
80-140	495	136	212	292	14	80	12	41	79	166	329	450	282	70
80-170	573	143	250	360	14	80	15	48	115	167	406	510	340	108



8.4 FRE - pump unit A6

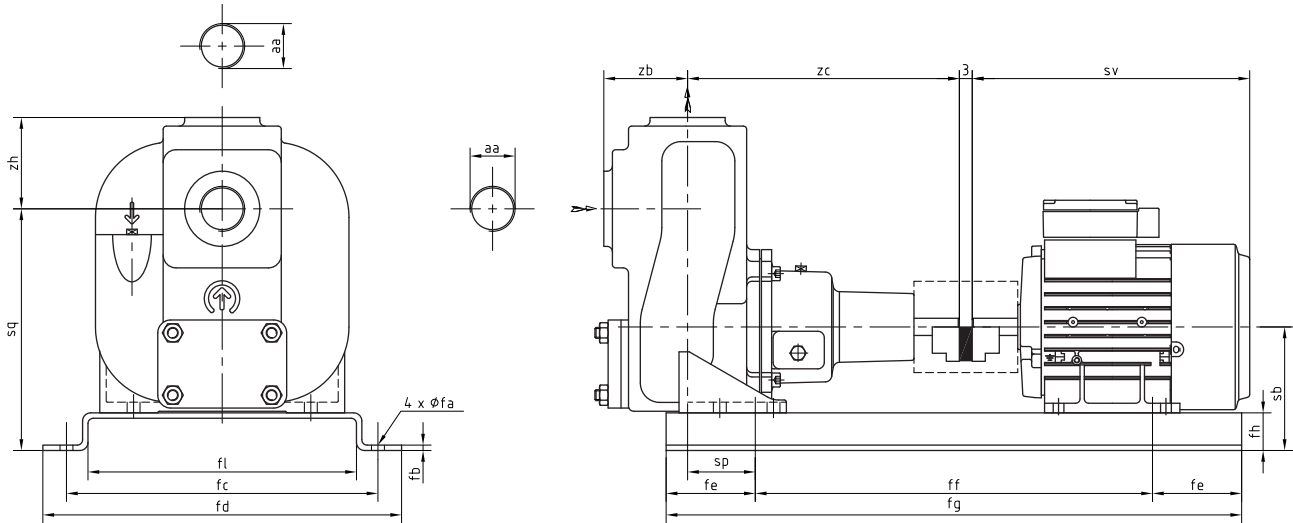

Figure 24: FRE - pump unit A6.

						IEC-motor							
						71	80	90 S	90 L	100 L	112 M	132 S	132 M
FRE	aa	zb	zc	zh	sv(*)	254	296	336	345	402	432	486	520
32-110	Rp 1 1/4	73	248	85	sb		115						
					sp		17						
					sq		220						
					X		2						
32-150	Rp 1 1/4	73	289	95	sb	135	135	135	135	135	147		
					sp	17	17	17	17	17	17		
					sq	240	240	240	240	240	252		
					X	2	2	2	2	2	2		
40-110	Rp 1 1/2	78	253	85	sb	115	115	125	125				
					sp	17	17	17	17				
					sq	225	225	235	235				
					X	2	2	2	2				
40-170	Rp 1 1/2	78	370	109	sb		205	205	205	205	205	205	
					sp		19	19	19	19	19	19	
					sq		330	330	330	330	330	330	
					X		3	3	3	3	3	3	

(\*) motor length based on DIN 42673, could be different due to applied motor make

Base plate dimensions [mm]

base plate nr. X	fa	fb	fc	fd	fe	ff	fg	fh	B
2	15	5	340	384	90	450	630	35	275
3	19	6	385	433	120	560	800	45	305

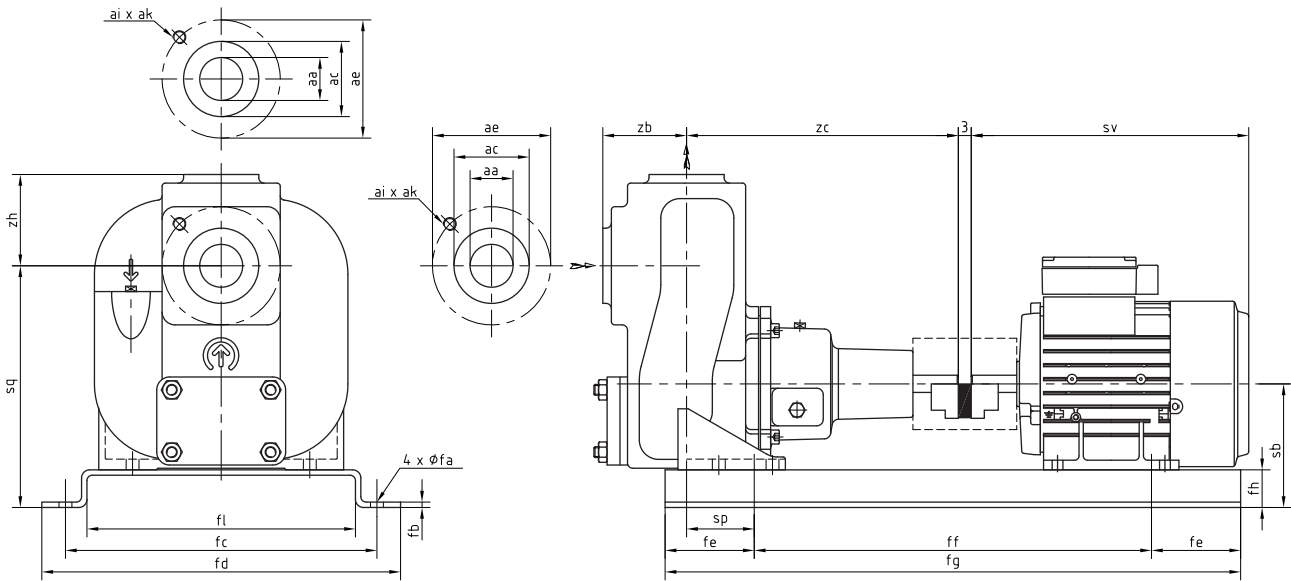

Figure 25: FRE - pump unit A6.

										IEC-motor									
										71	80	90 S	90 L	100 L	112 M	132 S	132 M	160 M	
FRE	aa	ac	ae	ai	ak	zb	zc	zh	sv(*)	254	296	336	345	402	432	486	520	652	
50-125b	Rp2(**)	100	125	4	M16	100	303	110	sb	135		135	135						
									sp	17		17	17						
									sq	255		255	255						
									X	2		2	2						
50-125	Rp2(**)	100	125	4	M16	100	303	110	sb	135	135		135	135	157				
									sp	17	17		17	17	17				
									sq	255	255		255	255	277				
									X	2	2		2	2	3				
50-205	Rp2	100	125	4	M16	105	384	140	sb				216	216					216
									sp				19	19					19
									sq				356	356					356
									X				4	4					4

(\*) motor length based on DIN 42673, could be different due to applied motor make

(\*\*) R6 : aa=50mm

Base plate dimensions [mm]

base plate nr. X	fa	fb	fc	fd	fe	ff	fg	fh	B
2	15	5	340	384	90	450	630	35	275
3	19	6	385	433	120	560	800	45	305
4	19	6	425	473	135	630	900	56	345

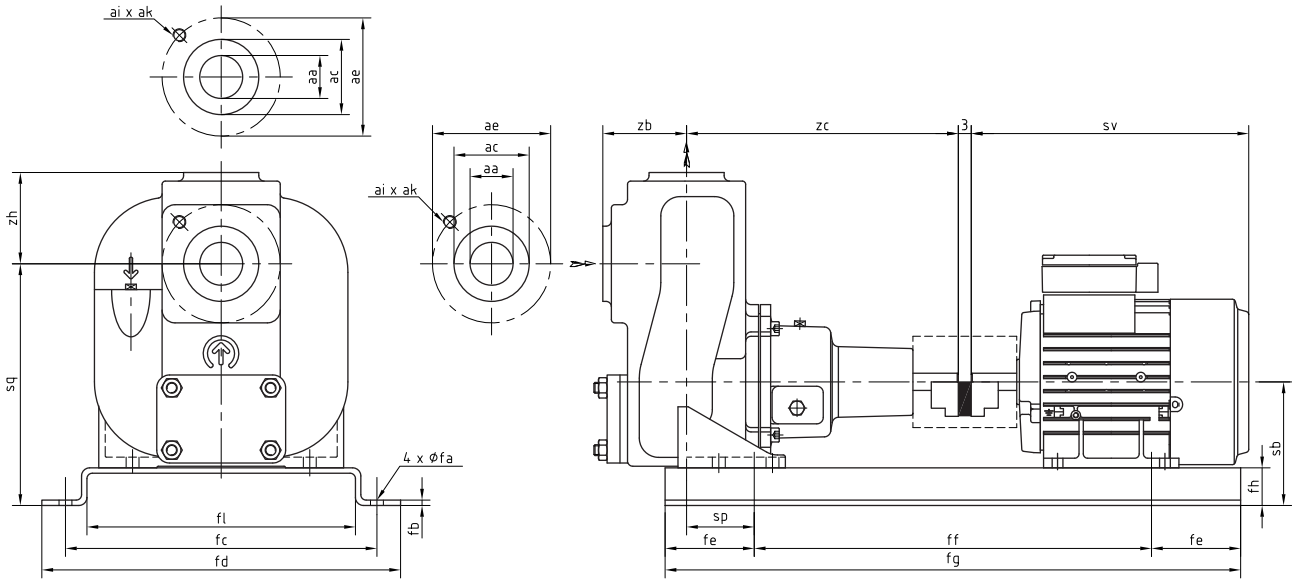

Figure 26: FRE - pump unit A6.

										IEC-motor										
										80	90 S	90 L	100 L	112 M	132 S	132 M	160 M	160 L		
FRE	aa	ac	ae	ai	ak	zb	zc	zh	sv(*)	296	336	345	402	432	486	520	652	672		
65-135b	65	120	145	4	M16	107	310	113	sb	147			157	157	177					
									sp	17			17	17	17					
									sq	287			297	297	317					
									X	2			3	3	3					
65-135	65	120	145	4	M16	107	310	113	sb	147			157	177						
									sp	17			17	17						
									sq	287			297	317						
									X	2			3	3						
65-155	65	120	145	4	M16	107	310	113	sb	177	177	177			177					
									sp	17	17	17			17					
									sq	327	327	327			327					
									X	3	3	3			3					
65-230	65	120	145	4	M16	115	390	150	sb				223	223					223	
									sp				19	19						19
									sq				388	388						388
									X				6	6						6

(\*) motor length based on DIN 42673, could be different due to applied motor make  
ISO 7005 PN 16 connections

Base plate dimensions [mm]

base plate nr. X	fa	fb	fc	fd	fe	ff	fg	fh	B
2	15	5	340	384	90	450	630	35	275
3	19	6	385	433	120	560	800	45	305
6	19	8	475	525	145	710	1000	63	385

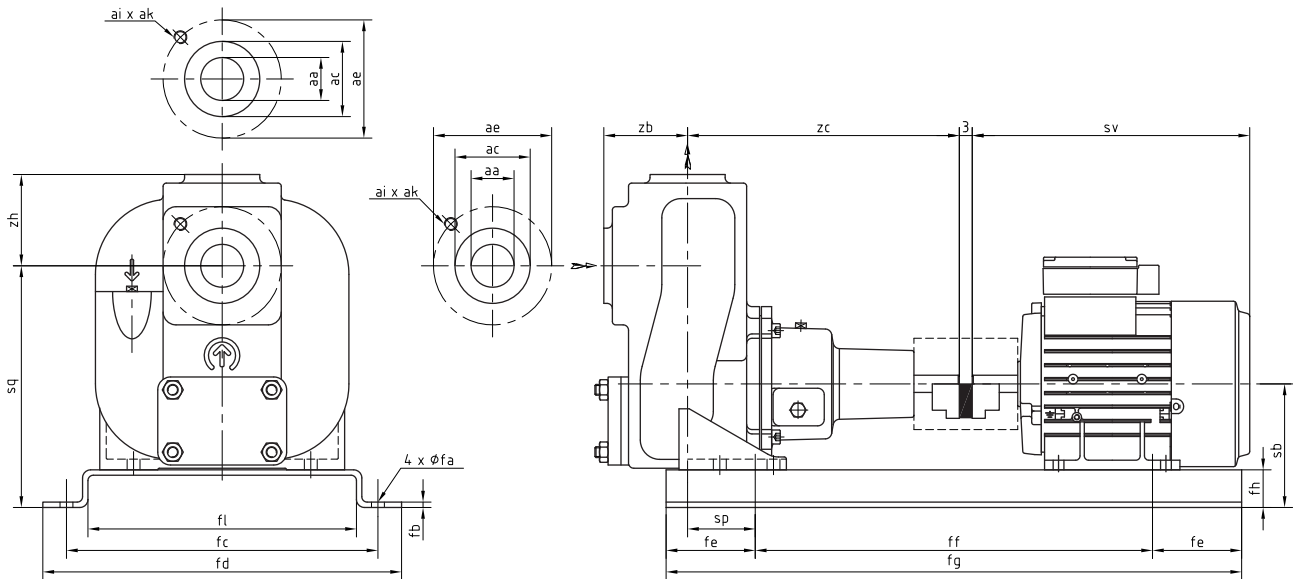

Figure 27: FRE - pump unit A6.

										IEC-motor								
										80	90 S	90 L	100 L	112 M	132 S	132 M	160 M	
FRE	aa	ac	ae	ai	ak	zb	zc	zh	sv(*)	269	336	345	402	432	486	520	652	
80-140	80	135	160	8	M16	126	329	128	sb	177	177			177	177			
									sp	17	17			17	17			
									sq	327	327			327	327			
									X	3	3			3	3			
80-170	80	135	160	8	M16	127	406	130	sb		223	223	223		223		223	
									sp		19	19	19		19		19	
									sq		403	403	403		403		403	
									X		6	6	6		6		6	
100-225b	100	155	180	8	M16	156	447	165	sb					290	290	290		
									sp					19	19	19		
									sq					520	520	520		
									X					7	7	7		
100-225	100	155	180	8	M16	156	447	165	sb				290	290	290		290	
									sp					19	19	19		19
									sq					520	520	520		520
									X					7	7	7		7

(\*) motor length based on DIN 42673, could be different due to applied motor make  
ISO 7005 PN 16 connections

Base plate dimensions [mm]

base plate nr. X	fa	fb	fc	fd	fe	ff	fg	fh	B
3	19	6	385	433	120	560	800	45	305
6	19	8	475	525	145	710	1000	63	385
7	24	10	610	678	175	900	1250	90	500

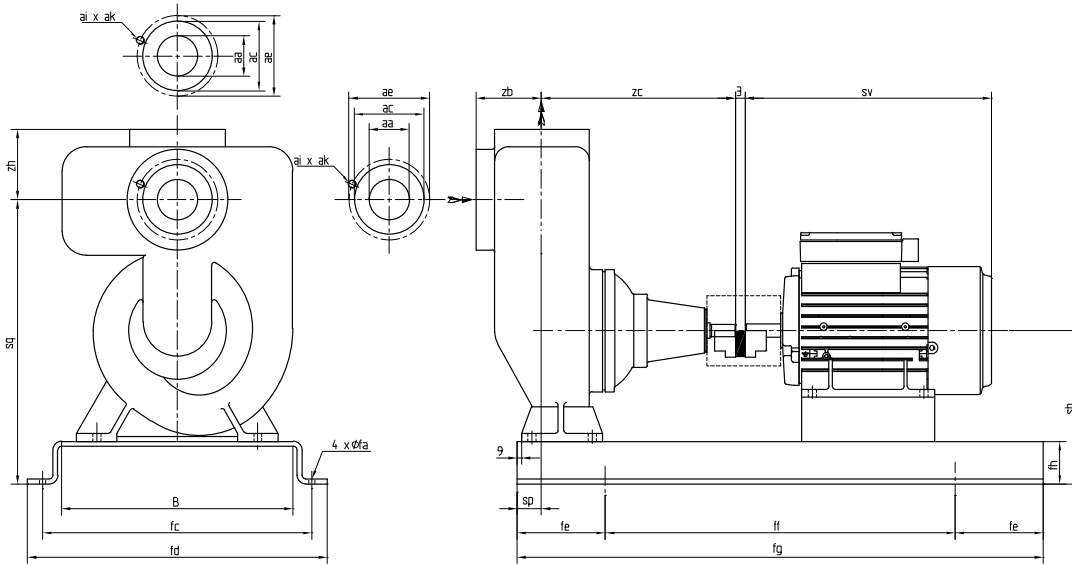

Figure 28: FRE - pump unit A6.

										IEC-motor					
										112 M	132 S	132 M	160 M	180 M	200 L
FRE	aa	ac	ae	ai	ak	zb	zc	zh	sv(*)	432	486	520	652	712	790
80-210	80	138	160	8	M16	130	385	140	sb	300	300				
									sp	48	48				
									sq	560	560				
									X	5	5				
100-250	100	158	180	8	M16	145	495	140	sb			360	360		
									sp			38	38		
									sq			670	670		
									X			5	5		
150-290b	150	212	240	8	M20	185	583	175	sb				340	340	
									sp				41	41	
									sq				630	630	
									X				7	7	
150-290	150	212	240	8	M20	185	583	175	sb					340	340
									sp					41	41
									sq					630	630
									X					7	7

(\*) motor length based on DIN 42673, could be different due to applied motor make

ISO 7005 PN 16 connections

Base plate dimensions [mm]

base plate nr. X	fa	fb	fc	fd	fe	ff	fg	fh	B
5	24	10	535	595	175	900	1250	80	425
6	19	8	475	525	145	710	1000	63	385
7	24	10	610	678	175	900	1250	90	500

## 8.5 FRE - pump unit A6, with ISO 7005 PN20 connections

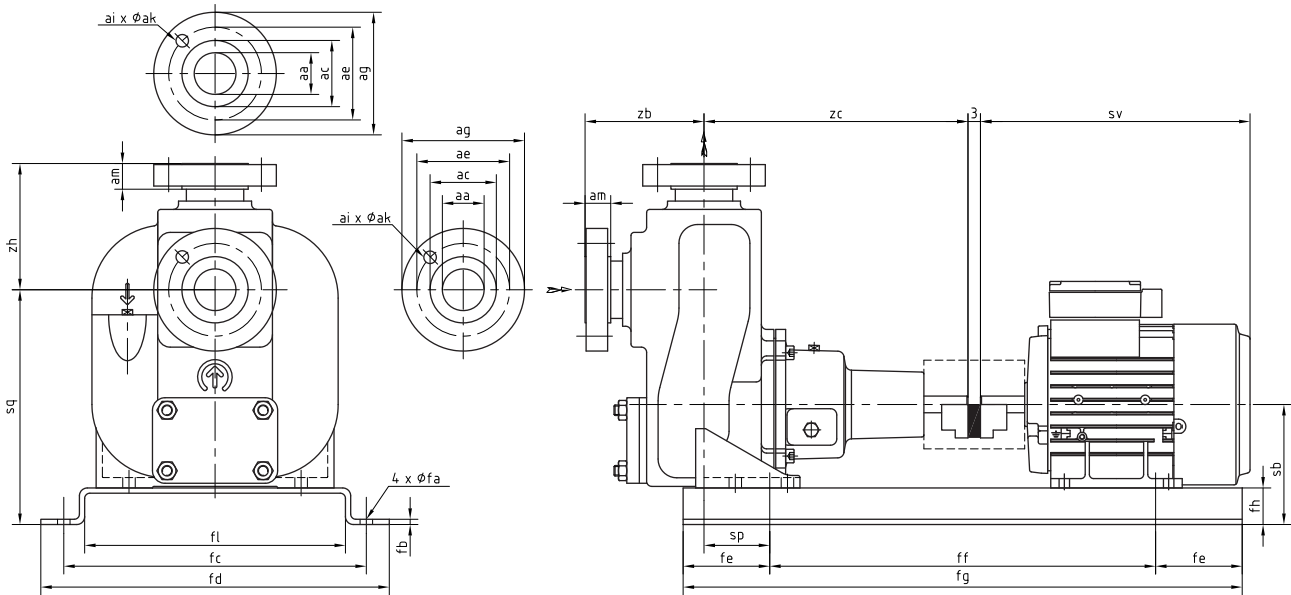

Figure 29: FRE - pump unit A6, with ISO 7005 PN20 connections.

												IEC-motor								
												71	80	90 S	90 L	100 L	112 M	132 S	132 M	
FRE	aa	ac	ae	ag	ai	ak	am	zb	zc	zh	sv(*)	254	296	336	345	402	432	486	520	
32-110	32	63,5	88,9	117,5	4	16	20,6	108	248	120	sb		115							
											sp		17							
											sq		220							
											X		2							
32-150	32	63,5	88,9	117,5	4	16	20,6	108	289	130	sb	135	135	135	135	135	147			
											sp	17	17	17	17	17	17			
											sq	240	240	240	240	240	252			
											X	2	2	2	2	2	2			
40-110	40	73	98,4	127	4	16	22,2	113	253	120	sb	115	115	125	125					
											sp	17	17	17	17					
											sq	225	225	235	235					
											X	2	2	2	2					
40-170	40	73	98,4	127	4	16	22,2	113	370	144	sb		205	205	205	205	205	205		
											sp		19	19	19	19	19	19		
											sq		330	330	330	330	330	330		
											X		3	3	3	3	3	3		

(\*) motor length based on DIN 42673, could be different due to applied motor make

Base plate dimensions [mm]

base plate nr. X	fa	fb	fc	fd	fe	ff	fg	fh	B
2	15	5	340	384	90	450	630	35	275
3	19	6	385	433	120	560	800	45	305

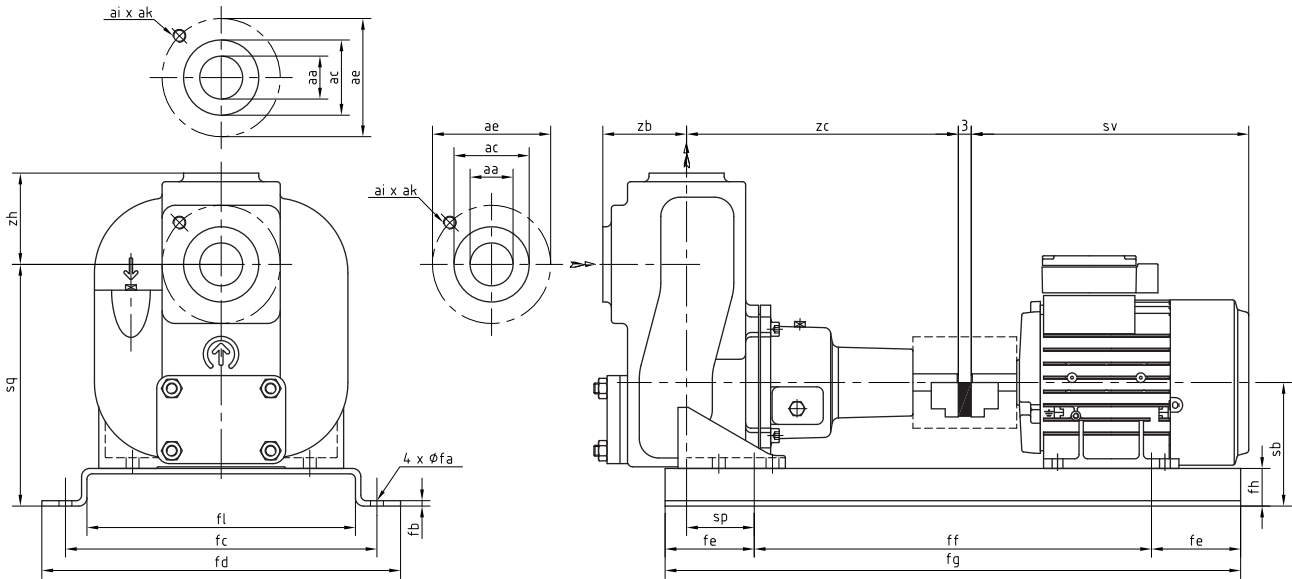

Figure 30: FRE - pump unit A6, with ISO 7005 PN20 connections.

										IEC-motor								
										71	80	90 S	90 L	100 L	112 M	132 S	132 M	160 M
FRE	aa	ac	ae (*)	ai	ak	zb	zc	zh	sv (**)	254	296	336	345	402	432	486	520	652
50-125b	50	100	120,7	4	M16	100	303	110	sb	135		135	135					
									sp	17		17	17					
									sq	255		255	255					
									X	2		2	2					
50-125	50	100	120,7	4	M16	100	303	110	sb	135	135		135	135	157			
									sp	17	17		17	17	17			
									sq	255	255		255	255	277			
									X	2	2		2	2	3			
50-205	50	100	120,7	4	M16	105	384	140	sb				216	216				216
									sp				19	19				19
									sq				356	356				356
									X				4	4				4

(\*) ae = according to PN20 + 0,2 mm

(\*\*) motor length based on DIN 42673, could be different due to applied motor make

Base plate dimensions [mm]

base plate nr. X	fa	fb	fc	fd	fe	ff	fg	fh	B
2	15	5	340	384	90	450	630	35	275
3	19	6	385	433	120	560	800	45	305
4	19	6	425	473	135	630	900	56	345

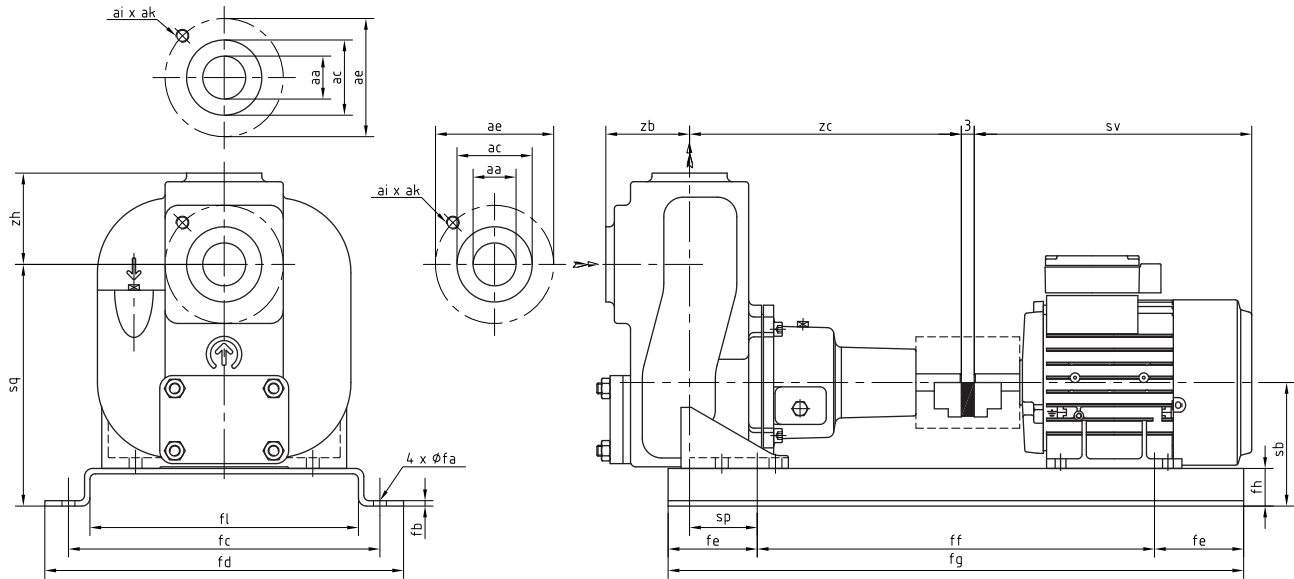

Figure 31: FRE - pump unit A6, with ISO 7005 PN20 connections.

											IEC-motor										
											80	90 S	90 L	100 L	112 M	132 S	132 M	160 M	160 L		
FRE	aa	ac	ae (*)	ai	ak	zb	zc	zh	sv (**)	296	336	345	402	432	486	520	652	672			
65-135b	65	120	139,7	4	M16	107	310	113	sb	147			157	157	177						
									sp	17			17	17	17						
									sq	287			297	297	317						
									X	2			3	3	3						
65-135	65	120	139,7	4	M16	107	310	113	sb	147				157	177						
									sp	17				17	17						
									sq	287				297	317						
									X	2				3	3						
65-155	65	120	139,7	4	M16	107	310	113	sb	177	177	177			177						
									sp	170	17	17			17						
									sq	327	327	327			327						
									X	3	3	3			3						
65-230	65	120	139,7	4	M16	115	390	150	sb				223	223					223		
									sp				19	19						19	
									sq				388	388						388	
									X				6	6						6	

(\*) ae = according to PN20 + 0,2 mm

(\*\*) motor length based on DIN 42673, could be different due to applied motor make

Base plate dimensions [mm]

base plate nr. X	fa	fb	fc	fd	fe	ff	fg	fh	B
2	15	5	340	384	90	450	630	35	275
3	19	6	385	433	120	560	800	45	305
6	19	8	475	525	145	710	1000	63	385



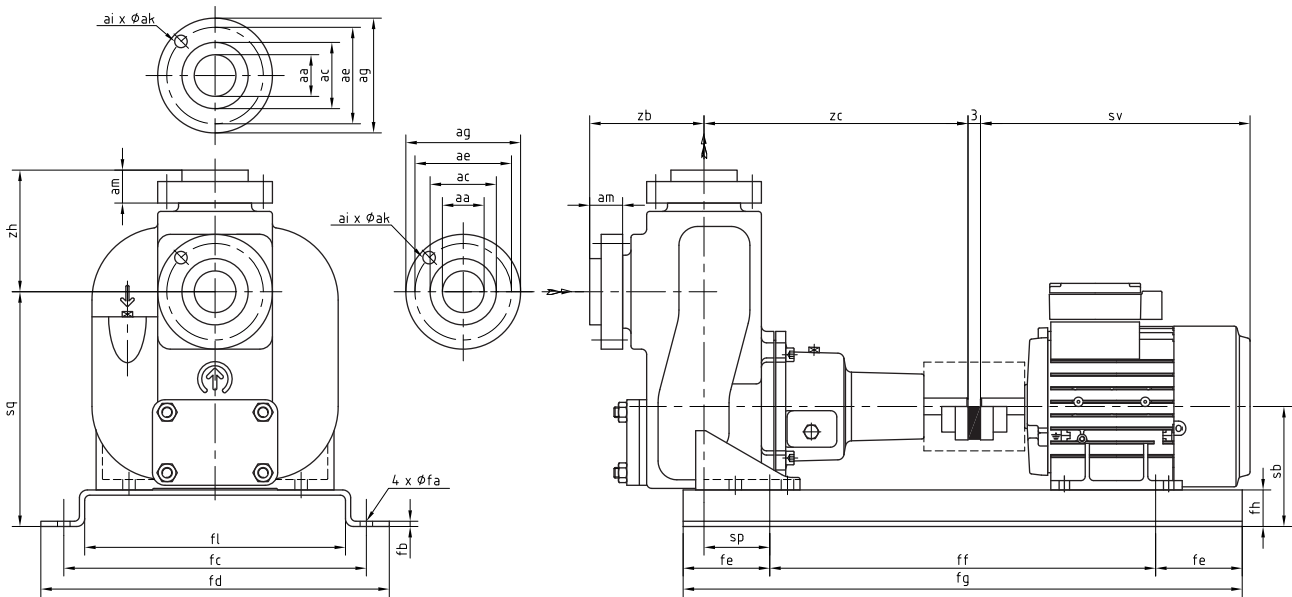

Figure 32: FRE - pump unit A6, with ISO 7005 PN20 connections.

											IEC-motor								
											80	90 S	90 L	100 L	112 M	132 S	132 M	160 M	
FRE	aa	ac	ae	ag	ai	ak	am	zb	zc	zh	sv(*)	296	336	345	402	432	486	520	652
80-140	80	135	152,5	192	4	M16	40	168	329	170	sb	177	177			177	177		
											sp	17	17			17	17		
											sq	327	327			327	327		
											X	3	3			3	3		
80-170	80	135	152,5	192	4	M16	40	169	406	172	sb		223	223	223		223		223
											sp		19	19	19		19		19
											sq		403	403	403		403		403
											X		6	6	6		6		6

(\*) motor length based on DIN 42673, could be different due to applied motor make

Base plate dimensions [mm]

base plate nr. X	fa	fb	fc	fd	fe	ff	fg	fh	B
3	19	6	385	433	120	560	800	45	305
6	19	8	475	525	145	710	1000	63	385

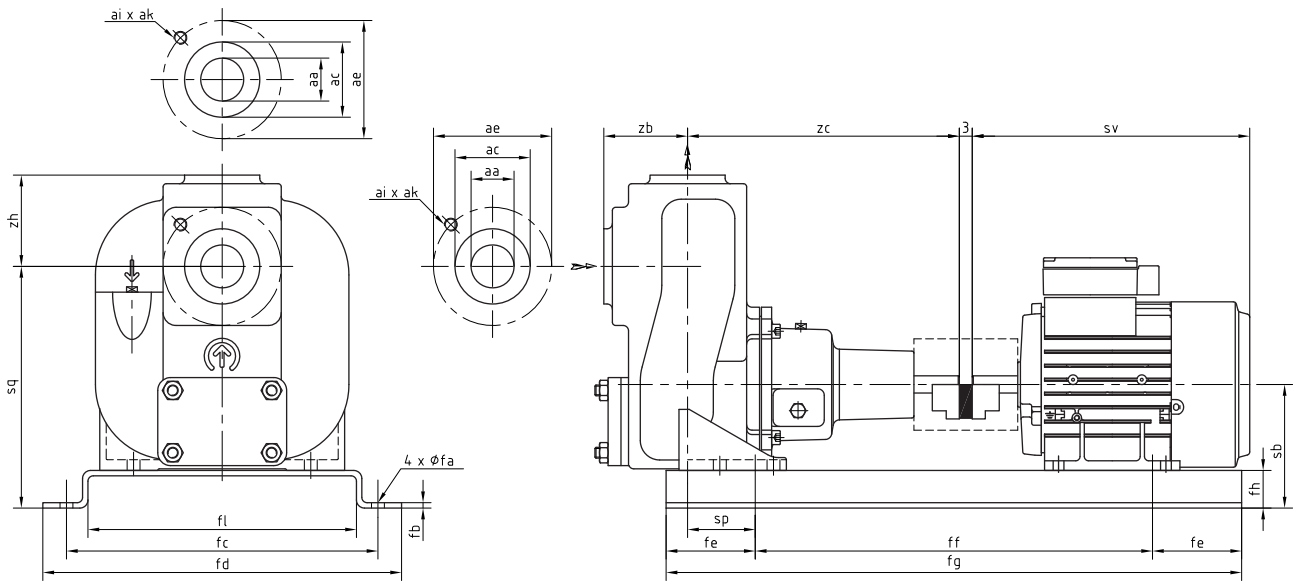

Figure 33: FRE - pump unit A6, with ISO 7005 PN20 connections.

										IEC-motor									
										80	90 S	90 L	100 L	112 M	132 S	132 M	160 M		
FRE	aa	ac	ae	ai	ak	zb	zc	zh	sv(*)	296	336	345	402	432	486	520	652		
100-225b	100	160	190,5	8	M16	156	447	165	sb					290	290	290			
									sp					19	19	19			
									sq					520	520	520			
									X					7	7	7			
100-225	100	160	190,5	8	M16	156	447	165	sb				290	290	290			290	
									sp					19	19	19			19
									sq					520	520	520			520
									X					7	7	7			7

(\*) motor length based on DIN 42673, could be different due to applied motor make

Base plate dimensions [mm]

base plate nr. X	fa	fb	fc	fd	fe	ff	fg	fh	B
7	24	10	610	678	175	900	1250	90	500

8.6 FRES

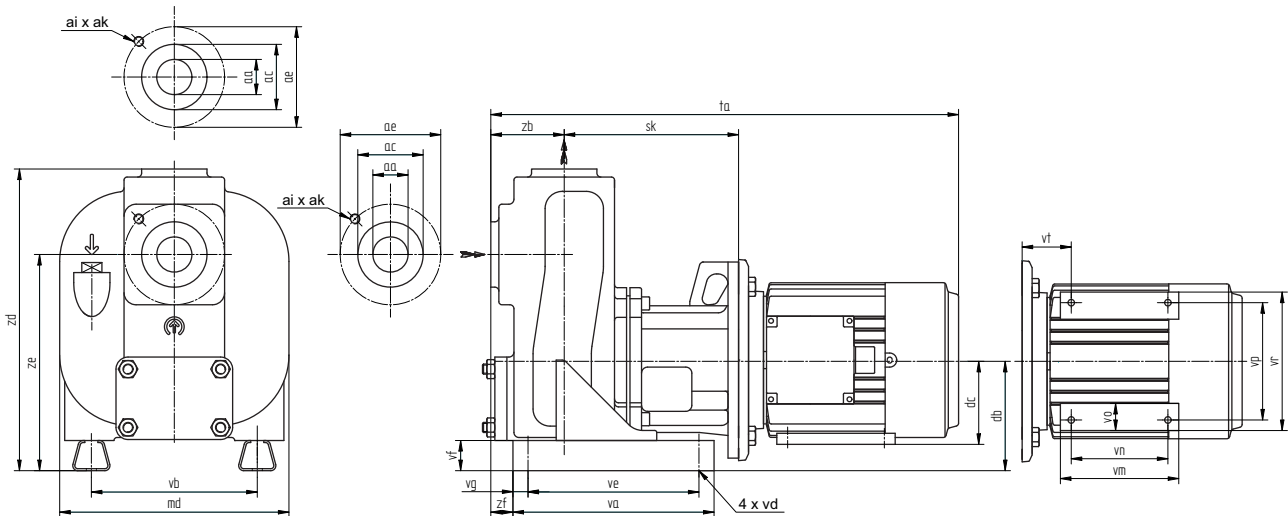

Figure 34: FRES.

FRES	IEC-motor	aa	ac	ae	ai	ak	db	dc	md	sk	ta(**)
32-110	80-F165	Rp 1¼	-	-	-	-	110	-	236	173	532
32-150	90L-F165	Rp 1¼	-	-	-	-	130	-	235	200	605
	112M-F215									212	677
40-110	80-F165	Rp 1½	-	-	-	-	110	-	244	178	542
40-170	112M-F215	Rp 1½	-	-	-	-	190	-	314	236	706
	132M-F265						180	132		264	830
50-125b	90S-F165	Rp 2 (*)	100	125	4	M16	130	-	280	214	622
	90L-F165									646	
	100L-F215									692	
	112M-F215									226	718
50-125	90L-F165	Rp 2 (*)	100	125	4	M16	130	-	280	214	646
	112M-F215									226	718
50-205	160M-F300	Rp 2	100	125	4	M16	180	160	318	311	964
65-135b	100L-F215	65	120	145	4	M16	142	-	268	233	706
	132S-F265						132	132		259	816
65-135	112M-F215	65	120	145	4	M16	142	-	268	233	732
	132S-F265						132	132		259	816
65-155	90S-F165	65	120	145	4	M16	162	-	308	221	636
	90L-F165									660	
	132S-F265						259	816			
	132M-F265						152	132		854	
65-230	160L-F300	65	120	145	4	M16	180	160	368	319	1024
80-140	90S-F165	80	135	160	8	M16	162	-	312	240	674
	90L-F165									698	
	112M-F215						252	770			
	132M-F265						152	132		278	892
80-170	160M-F300	80	135	160	8	M16	180	160	370	332	1007
100-225b	112M-F215	100	155	180	8	M16	220	-	452	303	851
	132S-F265							132		331	937
100-225	132S-F265	100	155	180	8	M16	220	132	452	331	937
	132M-F265									975	

aa ≥ 50 : ISO 7005 PN 16 connections

(\*) R6 : aa = 50

(\*\*) motor length based on DIN 42677, could be different due to applied motor make

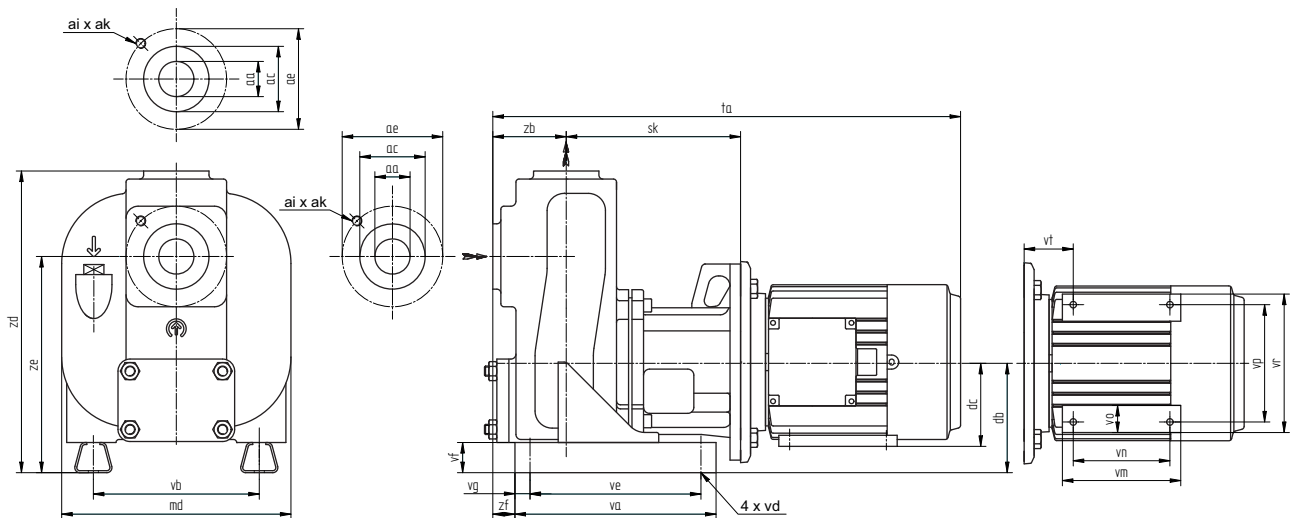

Figure 35: FRES.

FRES	IEC-motor	va	vb	vd	ve	vf	vg	vm <sup>(1)</sup>	vn	vp	vr <sup>(1)</sup>	vs	vt <sup>(1)</sup>	zb	zd	ze	zf	[kg]												
32-110	80-F165	200	165	12	170	30	15	-	-	-	-	-	-	73	300	215	22	30												
32-150	90L-F165	225	190	12	195	30	15	-	-	-	-	-	-	73	330	235	22	50												
	112M-F215	275			245													100												
40-110	80-F165	200	165	12	170	30	15	-	-	-	-	-	-	78	305	220	22	38												
40-170	112M-F215	275	222	12	245	30	15	-	-	-	-	-	-	78	424	315	22	90												
	132M-F265	330			200													20	20	224	178	216	270	12	89	414	305	25	140	
50-125b	90S-F165	225	190	12	195	30	15	-	-	-	-	-	-	100	360	250	35	60												
	90L-F165																	245	65											
	100L-F215	275			90																									
	112M-F215	275			110																									
50-125	90L-F165	225	190	12	195	30	15	-	-	-	-	-	-	100	360	250	35	60												
	112M-F215	275			245													110												
50-205	160M-F300	440	230	14	200	20	20	-	210	254	314	14,5	108	105	460	320	35	140												
65-135b	100L-F215	275	190	12	245	30	15	-	-	-	-	-	-	107	395	282	35	65												
	132S-F265	310			200													20	20	186	140	216	270	12	89	405	292	130		
65-135	112M-F215	275	190	12	245	30	15	-	-	-	-	-	-	107	395	282	35	75												
	132S-F265	310			200													20	20	186	140	216	270	12	89	405	292	130		
65-155	90S-F165	275	212	12	245	30	15	-	-	-	-	-	-	107	425	312	35	75												
	90L-F165																	245	80											
	132S-F265	330			14														200	20	20	186	140	216	270	12	89	415	302	105
	132M-F265																	224				178	216	125						
65-230	160L-F300	480	250	14	250	20	30	304	254	254	314	14,5	108	115	495	345	8	215												
80-140	90S-F165	275	212	12	245	30	15	-	-	-	-	-	-	126	440	312	35	65												
	90L-F165																	245	70											
	112M-F215	500			14														250	20	30	224	178	216	270	12	89	430	302	29
	132M-F265																	500												
80-170	160M-F300	500	250	14	250	20	30	260	210	254	314	14,5	108	127	490	360	35	210												
100-225b	112M-F215	500	315	14	320	20	30	-	-	-	-	-	-	156	615	450	37	200												
	132S-F265																	500	315	14	320	20	30	186	140	216	270	12	89	230
100-225	132S-F265	500	315	14	320	20	30	186	140	216	270	12	89	156	615	450	37	200												
	132M-F265																	500	315	14	320	20	30	224	178	216	270	12	89	220

(1) Motor feet based on standard motor, could be different due to applied motor make.

8.7 FRES with ISO 7005 PN20 connections

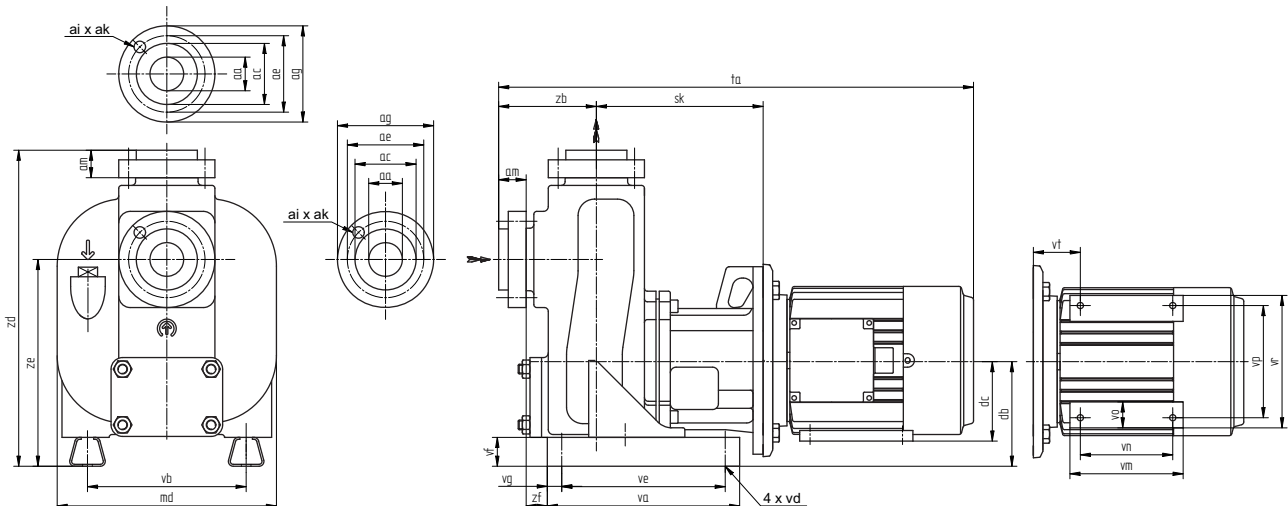

Figure 36: FRES with ISO 7005 PN20 connections.

FRES	IEC-motor	aa	ac	ae	ag	ai	ak	am	db	md	sk	ta(*)
32-110	80-F165	32	63,5	88,9	117,5	4	M16	20,6	110	236	173	594
32-150	90L-F165	32	63,5	88,9	117,5	4	M16	20,6	130	235	200	640
	112M-F215										212	712
40-110	80-F165	40	73	98,4	127	4	M16	22,2	110	244	178	577
40-170	112M-F215	40	73	98,4	127	4	M16	22,2	190	314	236	741
	132M-F265								180		264	865

(\*) motor length based on DIN 42677, could be different due to applied motor make

FRES	IEC-motor	va	vb	vd	ve	vf	vg	vm <sup>(1)</sup>	vn	vp	vr <sup>(1)</sup>	vs	vt <sup>(1)</sup>	zb	zd	ze	zf	[kg]
32-110	80-F165	200	165	12	170	30	15	-	-	-	--	-	-	108	335	215	22	33
32-150	90L-F165	225	190	12	195	30	15	-	-	-	-	-	-	108	365	235	22	53
	112M-F215	275			245													103
40-110	80-F165	200	165	12	170	30	15	-	-	-	--	-	-	113	340	220	22	42
40-170	112M-F215	275	222	12	245	30	15	-	-	-	--	-	-	113	459	315	22	94
	132M-F265	330			14													200

(1) Motor feet based on standard motor, could be different due to applied motor make

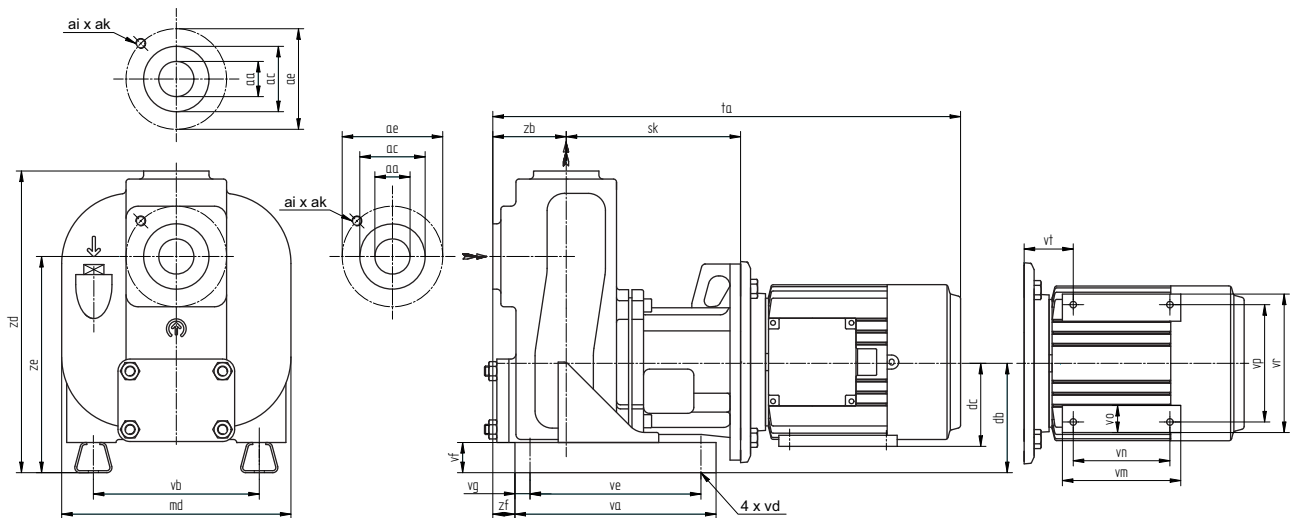

Figure 37: FRES with ISO 7005 PN20 connections.

FRES	IEC-motor	aa	ac	ae	ai	ak	db	md	sk	ta (**)
50-125b	90S-F165	50	100	120,7 (*)	4	M16	130	280	214	622
	90L-F165									646
	100L-F215									680
	112M-F215									706
50-125	90L-F165	50	100	120,7 (*)	4	M16	130	280	214	646
	112M-F215								226	718
50-205	160M-F300	50	100	120,7 (*)	4	M16	180	318	311	964
65-135b	100L-F215	65	120	139,7 (*)	4	M16	142	268	235	708
	132S-F265						152		261	818
65-135	112M-F215	65	120	139,7 (*)	4	M16	142	268	235	734
	132S-F265						152		261	818
65-155	90S-F165	65	120	139,7 (*)	4	M16	142	308	221	636
	90L-F165						553			
	132S-F265						259		816	
	132M-F265								854	
65-230	160L-F300	65	120	139,7 (*)	4	M16	180	368	319	1026
100-225b	112M-F215	100	155	190,5	8	M16	220	452	308	856
	132S-F265								336	942
100-225	132S-F265	100	155	190,5	8	M16	220	452	336	942
	132M-F265								980	

(\*) ae = according to PN20 + 0,2 mm

(\*\*) motor length based on DIN 42677, could be different due to applied motor make

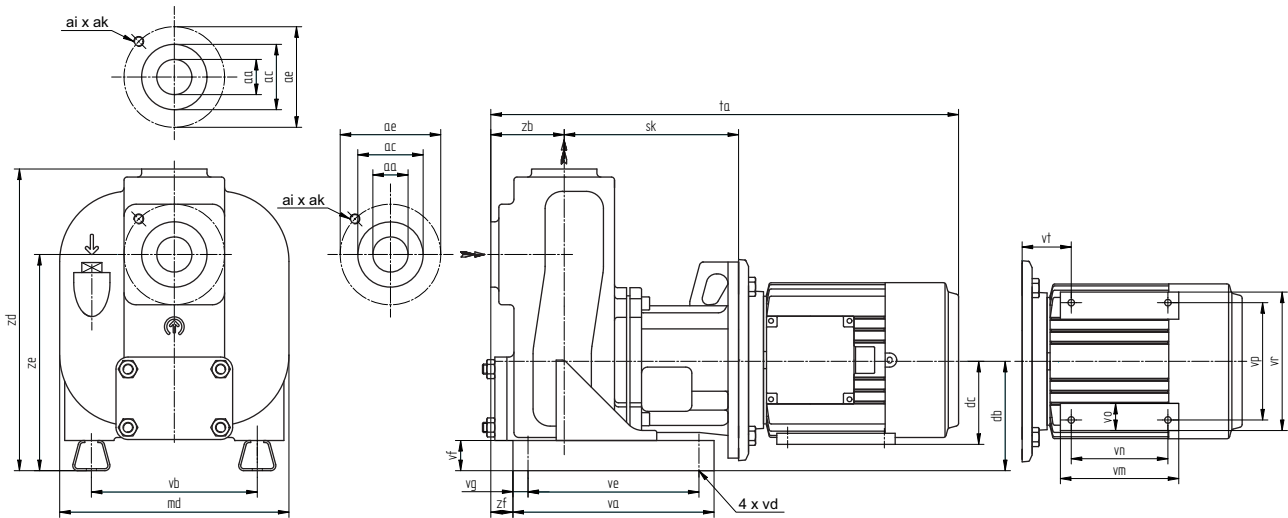

Figure 38: FRES with ISO 7005 PN20 connections.

FRES	IEC-motor	va	vb	vd	ve	vf	vg	vm <sup>(1)</sup>	vn	vp	vr <sup>(1)</sup>	vs	vt <sup>(1)</sup>	zb	zd	ze	zf	[kg]									
50-125b	90S-F165	225	190	12	195	30	15	-	-	-	-	-	-	100	360	250	35	60									
	90L-F165				65																						
	100L-F215	275			245													90									
	112M-F215				100																						
50-125	90L-F165	225	190	12	195	30	15	-	-	-	-	-	-	100	360	250	35	60									
	112M-F215	275			245													110									
50-205	160M-F300	440	230	14	200	20	20	260	210	254	314	14,5	108	105	460	320	35	140									
65-135b	100L-F215	275	190	12	245	30	15	-	-	-	-	-	-	107	395	282	35	65									
	132S-F265	310			14										200	20		20	186	140	216	270	12	89	385	272	120
65-135	112M-F215	275	190	12	245	30	15	-	-	-	-	-	-	107	395	282	35	75									
	132S-F265	310			14										200	20		20	186	140	216	270	12	89	405	292	130
65-155	90S-F165	275	212	12	245	30	15	-	-	-	-	-	-	107	425	312	35	75									
	90L-F165				80																						
	132S-F265	330			14										200	20		20	186	140	216	270	12	89	415	302	105
	132M-F265																		224	178							125
65-230	160L-F300	480	250	14	250	20	30	304	254	254	314	14,5	108	115	495	345	40	215									
100-225b	112M-F215	500	315	14	320	20	30	-	-	-	-	-	-	156	615	450	37	200									
	132S-F265							186	140	216	270	12	89					230									
100-225	132S-F265	500	315	14	320	20	30	186	140	216	270	12	89	156	615	450	37	200									
	132M-F265							224	178									220									

<sup>(1)</sup> Motor feet based on standard motor, could be different due to applied motor make

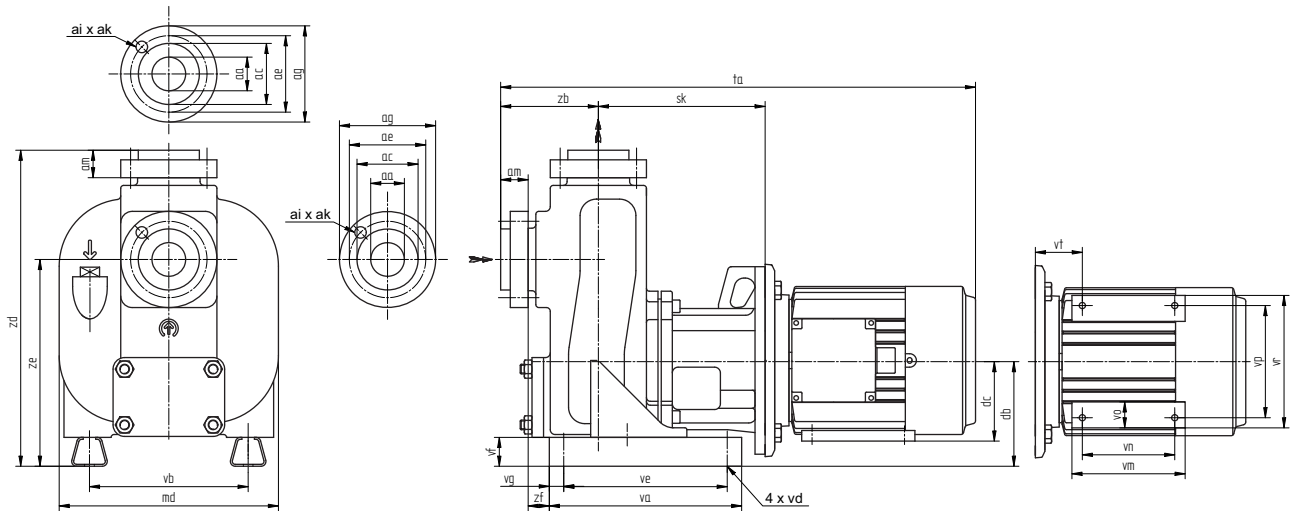

Figure 39: FRES with ISO 7005 PN20 connections.

FRES	IEC-motor	aa	ac	ae	ag	ai	ak	am	db	md	sk	ta (**)
80-140	90S-F165	80	135	152,5	192	4	M16	40	162	312	240	714
	90L-F165											738
	112M-F215											810
	132M-F265								152		278	932
80-170	160M-F300	80	135	152,5	192	4	M16	40	180	370	334	1093

(\*\*) motor length based on DIN 42677, could be different due to applied motor make

FRES	IEC-motor	va	vb	vd	ve	vf	vg	vm <sup>(1)</sup>	vn	vp	vr <sup>(1)</sup>	vs	vt <sup>(1)</sup>	zb	zd	ze	zf	[kg]
80-140	90S-F165	275	212	12	245	30	15	-	-	-	-	-	-	168	482	312	35	73
	90S-F165																	78
	112M-F215																	98
	132M-F265																	500
80-170	160M-F300	500	250	14	250	20	30	260	210	254	314	14,5	108	169	532	360	35	218

(1) Motor feet based on standard motor, could be different due to applied motor make



8.8 FREM

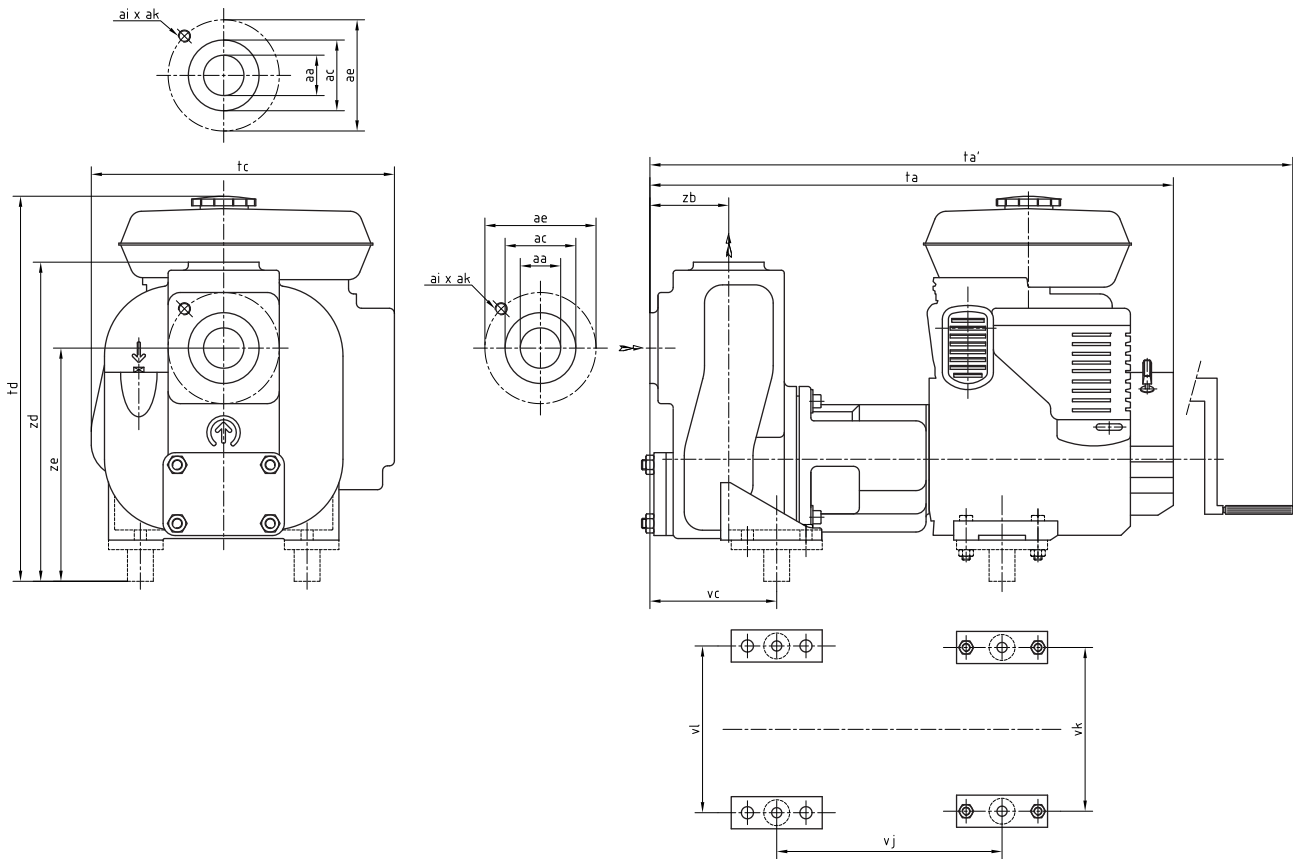

Figure 40: FREM.

FREM	motor	aa	ac	ae	ai	ak	ta	ta'	tc	td
32-150	EY20DU	Rp 1 1/4	-	-	-	-	540	-	317	432
	DY23DU	Rp 1 1/4	-	-	-	-	554	-	379	438
40-110	EY15DU	Rp 1 1/2	-	-	-	-	518	-	300	408
50-125b	EY15DU	Rp 2	125	125	4	M16	566	-	300	408
50-125	EY20DU	Rp 2	125	125	4	M16	584	-	317	432
	DY23DU	Rp 2	125	125	4	M16	596	-	379	438
65-135b	EY28DU	65	145	145	4	M16	663	-	386	480
	DY27DU	65	145	145	4	M16	621	-	379	440
	DY30DU	65	145	145	4	M16	718	-	370	490
65-135	EY28DU	65	145	145	4	M16	663	-	386	480
	DY27DU	65	145	145	4	M16	621	-	379	440
	DY30DU	65	145	145	4	M16	718	-	370	490
65-155	EH34DU	65	145	145	4	M16	647	-	395	534
	DY41DU	65	145	145	4	M16	-	850	370	520
80-140	EY28DU	80	160	160	8	M16	699	-	386	498
	EH35DU	80	160	160	8	M16	715	-	418	541
	DY35DU	80	160	160	8	M16	754	-	370	500

aa ≥ 50 : ISO 7005 PN 16 connections

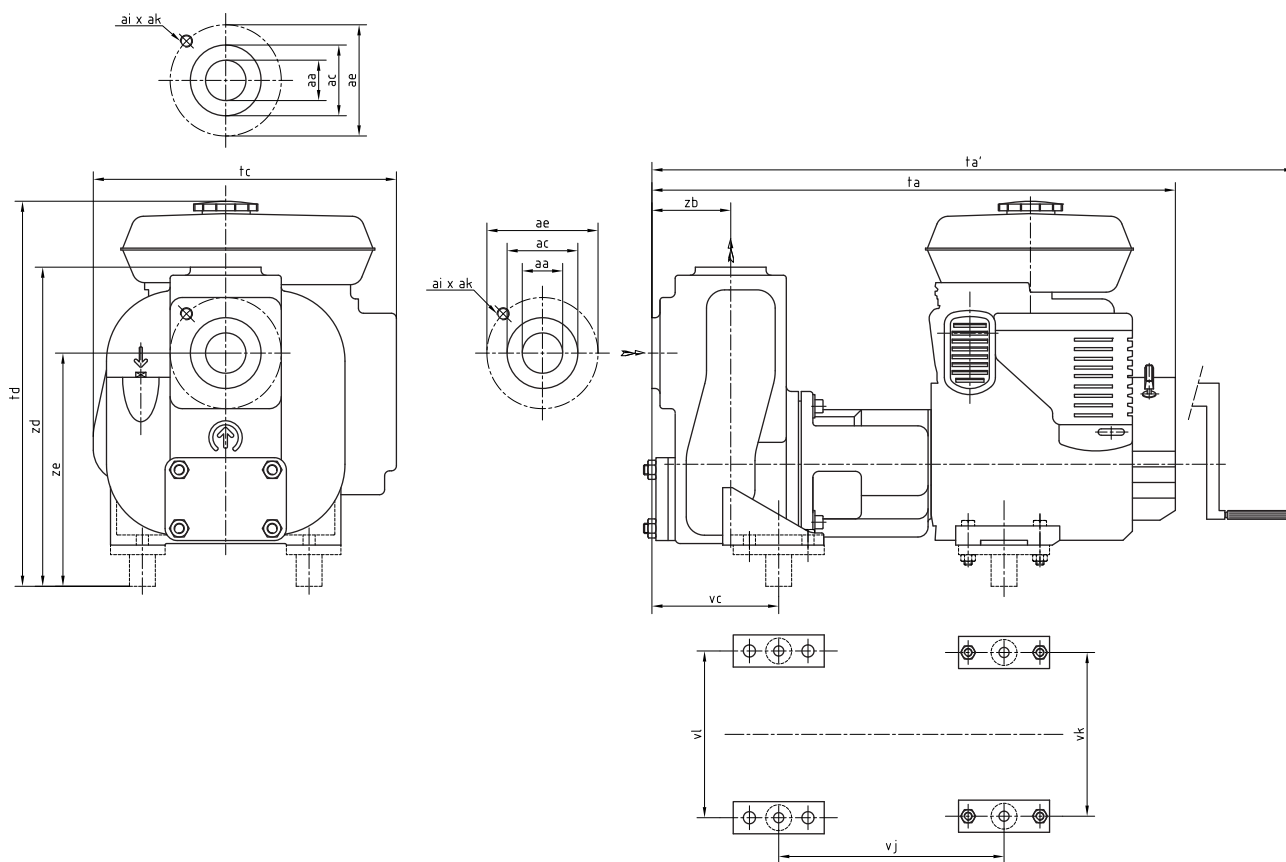

Figure 41: FREM.

FREM	motor	vc	vl	vj	vk	vm	zb	ze	zd	frame	[kg]
32-150	EY20DU	120,5	190	240	162	110	73	245	340	2	50
	DY23DU	120,5	190	286	240	105	73	265	360	2	60
40-110	EY15DU	133	165	223	162	120	78	250	335	1	35
50-125b	EY15DU	160	190	244	162	130	100	260	370	2	50
50-125	EY20DU	160	190	242	162	140	100	245	370	2	55
	DY23DU	160	190	289	240	130	100	285	390	2	65
65-135b	EY28DU	170	190	288	210	190	107	294	407	2	58
	DY27DU	170	190	295	240	210	107	302	415	2	64
	DY30DU	170	190	328	220	180	107	322	435	3	74
65-135	EY28DU	170	190	288	210	190	107	294	407	2	58
	DY27DU	170	190	295	240	210	107	302	415	2	64
	DY30DU	170	190	328	220	180	107	322	435	3	74
65-155	EH34DU	161	212	327	195	135	107	332	445	3	80
	DY41DU	161	212	334	250	150	107	337	450	3	90
80-140	EY28DU	199	212	295	210	200	126	322	450	3	75
	EH35DU	199	212	318	220	190	126	334	462	3	80
	DY35DU	199	212	335	220	140	126	342	470	3	95

	frame		
	1	2	3
a	670	810	870
b	420	450	510
c	520	700	720
d	490	535	595
e	25	35	15
f	50	50	100
vm	see previous page		

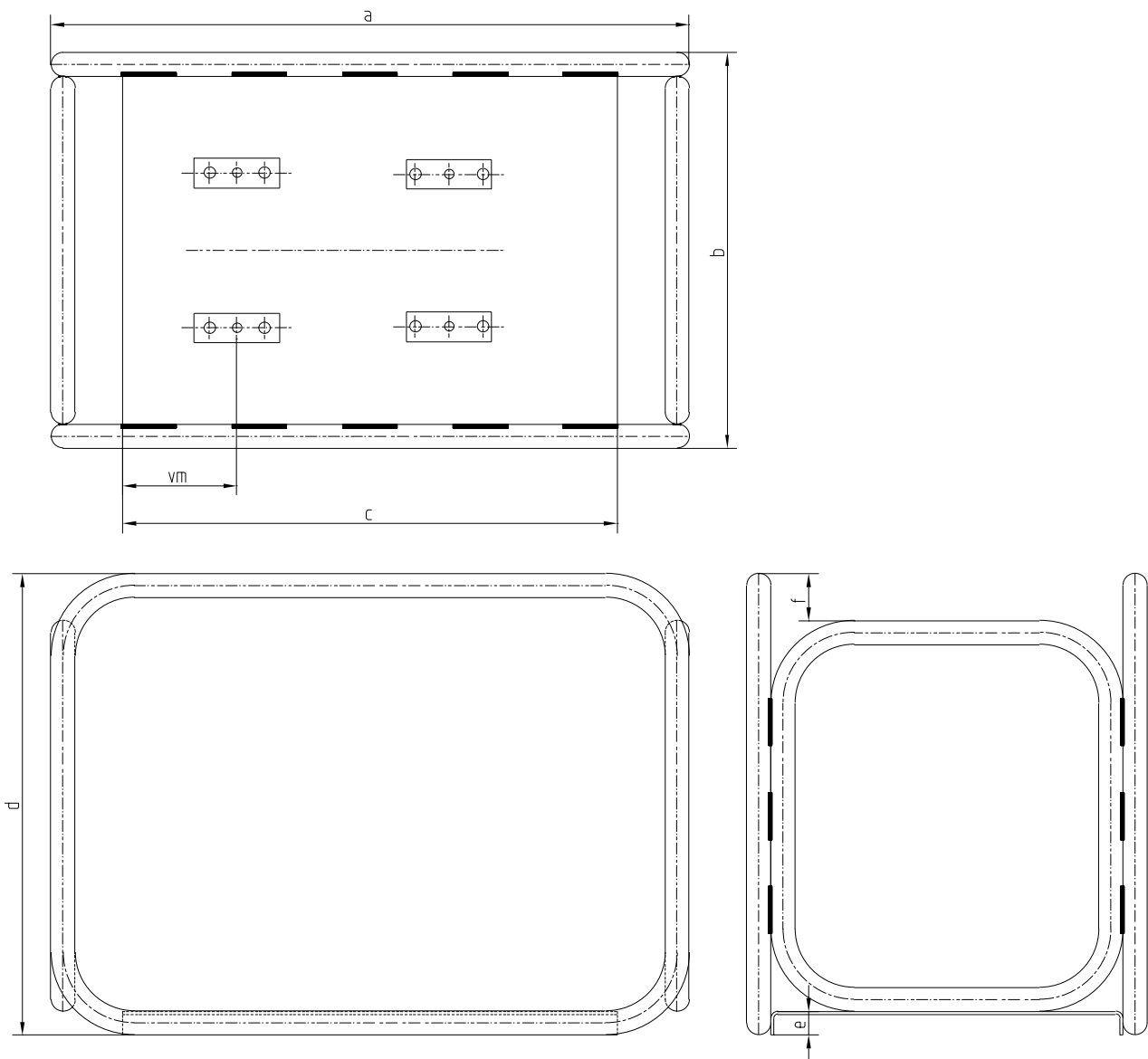

Figure 42: Frame dimensions.

## 8.9 FREF

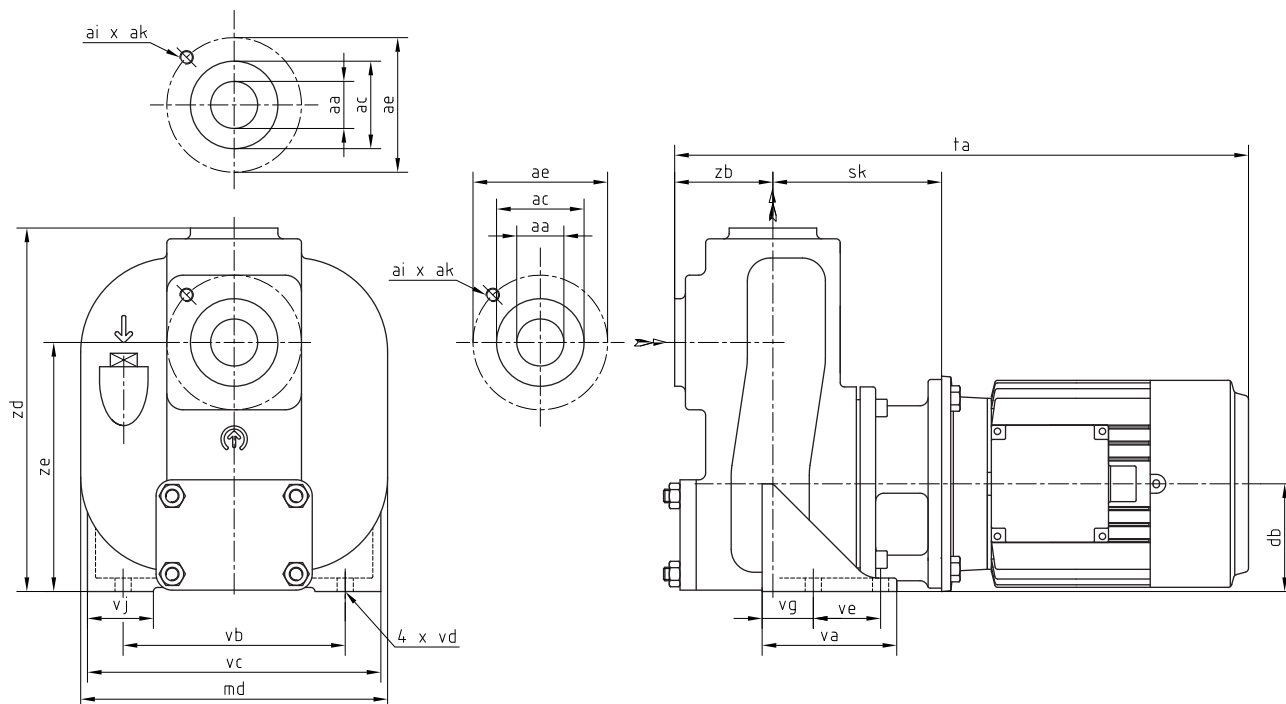

Figure 43: FREF.

FREF	motor	P [kW]	aa	ac	ae	ai	ak	db	md	sk	ta (*)
32-110	80 - F130	0,75	Rp 1¼	-	-	-	-	80	236	126	485
32-150	90L - F165	2,2	Rp 1¼	-	-	-	-	100	235	138	543
40-110	80 - F130	1,1	Rp 1½	-	-	-	-	80	244	131	495
50-125b	90S - F165	1,5	Rp 2	100	125	4	M16	100	280	152	560
50-125	90L - F165	2,2	Rp 2	100	125	4	M16	100	280	152	584
65-135b	100L - F215	3	65	120	145	4	M16	112	268	159	632
65-135	100L - F215	4	65	120	145	4	M16	112	268	159	632
65-155	112M - F215	5,5	65	120	145	4	M16	132	308	159	658
80-140	100L - F215	4	80	135	160	8	M16	132	321	178	670

aa ≥ 50 : ISO 7005 PN 16 connections

(\*) motor length based on DIN 42677, could be different due to applied motor make

FREF	motor	va	vb	vc	vd	ve	vf	vg	vj	zb	zd	ze	[kg]
32-110	80 - F130	95	165	228	12	50	10	33	54	73	270	185	31
32-150	90L - F165	91	190	240	12	40	12	36	75	73	300	205	43
40-110	80 - F130	110	165	228	12	50	10	38	54	78	275	190	32
50-125b	90S - F165	105	190	260	14	60	12	33	63	100	330	220	50
50-125	90L - F165	105	190	260	14	60	12	33	63	100	330	220	50
65-135b	100L - F215	111	190	260	14	60	12	36	75	107	365	252	52
65-135	100L - F215	111	190	260	14	60	12	36	75	107	365	252	62
65-155	112M - F215	112	212	292	14	70	12	27	83	107	395	282	92
80-140	100L - F215	136	212	292	14	80	12	41	79	126	410	282	76

## 9 Parts

### 9.1 Ordering parts

#### 9.1.1 Order form

You can use the order form included in this manual for ordering parts.

When ordering parts always quote the following data:

- 1 Your **address**.
- 2 The **quantity, the item number and the description** of the part.
- 3 The **pump number**. The pump number is stated on the label on the cover of this manual and on the type plate of the pump.
- 4 In the event of different electric motor voltage you should state the correct voltage.

#### 9.1.2 Recommended spare parts

Parts marked with a \* are recommended spare parts.

## 9.2 Pump FRE - bearing group 1

### 9.2.1 Sectional drawing FRE - bearing group 1

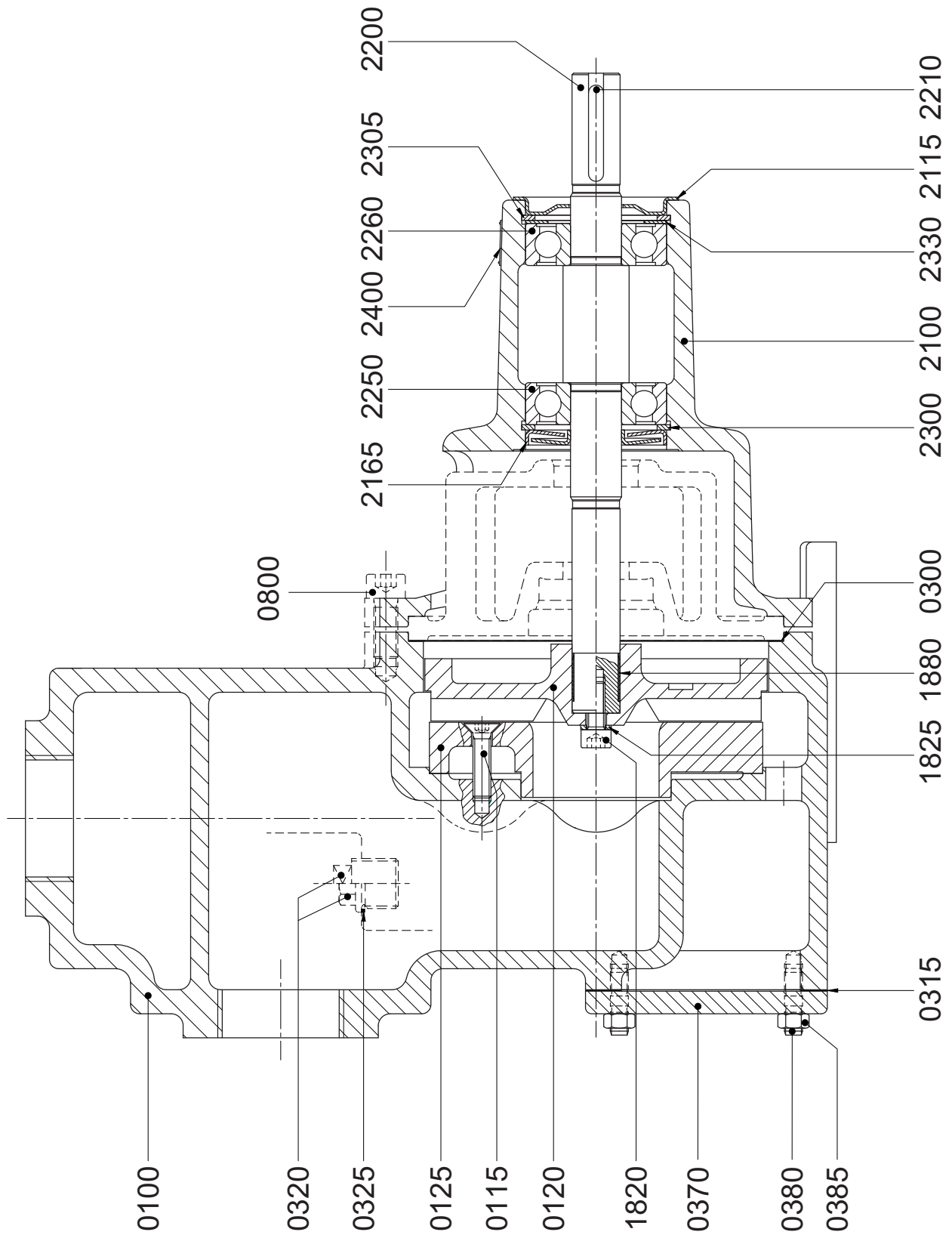

Figure 44: Sectional drawing FRE - bearing group 1.

9.2.2 Parts list FRE - bearing group 1

Item	Quantity	Description	Material				
			G1	G2	G6	B2	R6
0100	1	pump casing	cast iron			bronze	stainless steel
0115	2	countersunk screw	stainless steel				
0120*	1	impeller	cast iron	bronze	stainless steel	bronze	stainless steel
0125*	1	wear plate	cast iron		stainless steel	bronze	stainless steel
0300*	1	gasket	--				
0315*	1	gasket	--				
0320	1	plug	cast iron			stainless steel	
0325*	1	sealing ring	n/a				--
0370	1	cleaning cover	cast iron			bronze	stainless steel
0380	4	stud	stainless steel				
0385	4	nut	stainless steel				
0800	4	Allen screw	steel				stainless steel
1820*	1	Allen screw	stainless steel				
1825*	1	spring washer	stainless steel				
1880*	1	tolerance ring	stainless steel				
2100	1	bearing bracket	cast iron				
2115	1	bearing cover	steel				
2165	1	sealing segment	steel				
2200*	1	pump shaft	stainless steel				
2210*	1	key	steel				
2250*	1	ball bearing	steel				
2260*	1	ball bearing	steel				
2300*	1	inner circlip	steel				
2305*	1	inner circlip	steel				
2330	1	adjusting ring	steel				
2400	1	name plate	stainless steel				

-- Material not specified

n/a Not applicable

## 9.3 Pump FRE - bearing group 2

### 9.3.1 Sectional drawing FRE - bearing group 2

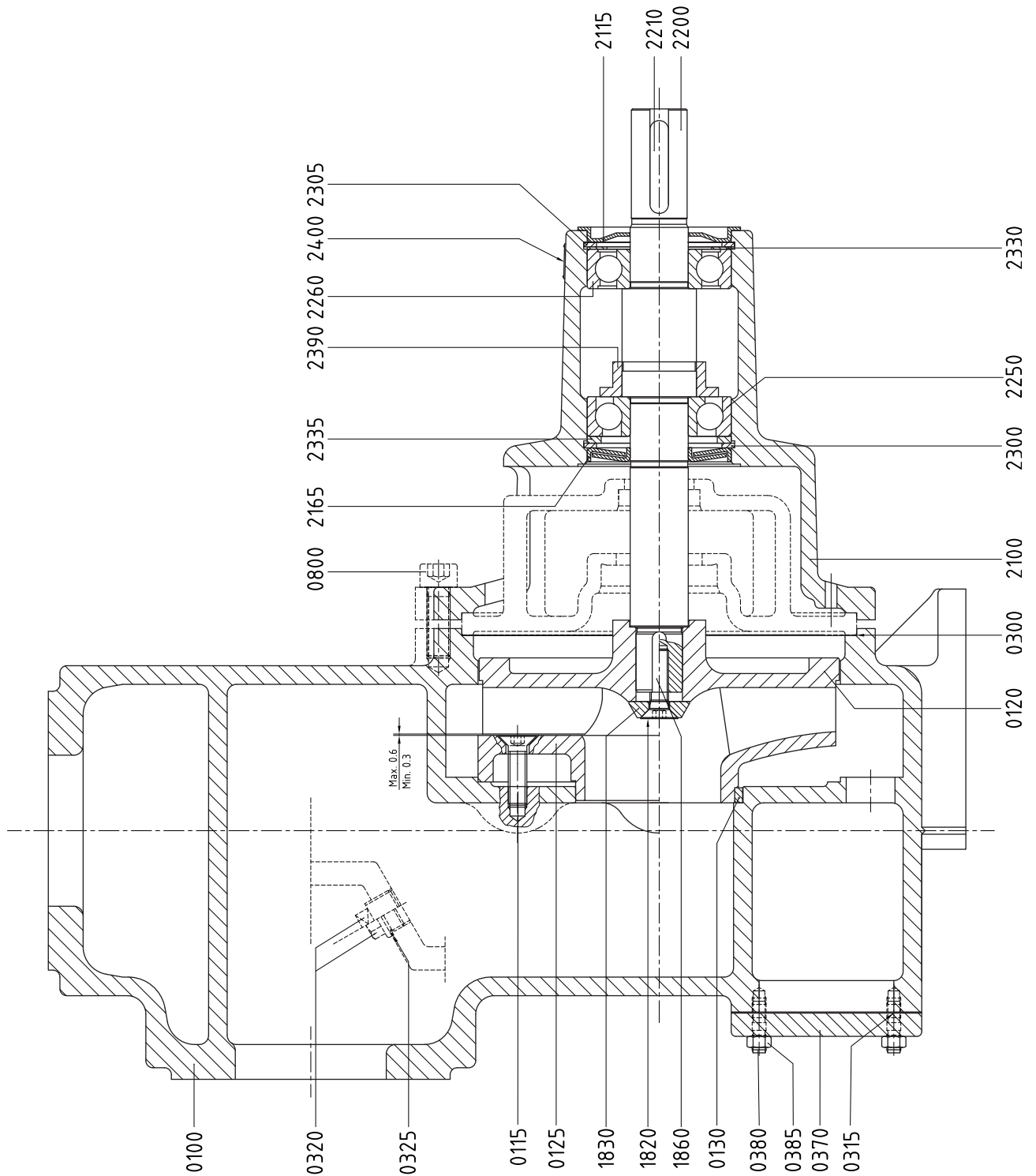

Figure 45: Sectional drawing FRE - bearing group 2.



9.3.2 Parts list FRE - bearing group 2

Item	Quantity	Description	Material				
			G1	G2	G6	B2	R6
0100	1	pump casing	cast iron			bronze	stainless steel
0115	2 <sup>1)</sup>	countersunk screw	stainless steel				
0120*	1	impeller	cast iron	bronze	stainless steel	bronze	stainless steel
0125*	1 <sup>1)</sup>	wear plate	cast iron		stainless steel	bronze	stainless steel
0130*	1 <sup>2)</sup>	wear ring	cast iron	bronze	stainless steel	bronze	stainless steel
0300*	1	gasket	--				
0315*	1	gasket	--				
0320	1	plug	cast iron			stainless steel	
0325*	1	sealing ring	n/a				--
0370	1	cleaning cover	cast iron			bronze	stainless steel
0380	4	stud	stainless steel				
0385	4	nut	stainless steel				
0800	6	Allen screw	steel				stainless steel
1820*	1	countersunk screw	stainless steel				
1830*	1	washer	stainless steel				
1860*	1	key	stainless steel				
2100	1	bearing bracket	cast iron				
2115	1	bearing cover	steel				
2165	1	sealing segment	steel				
2200*	1	pump shaft	stainless steel				
2210*	1	key	steel				
2250*	1	angular contact ball bearing	steel				
2260*	1	ball bearing	steel				
2300*	1	inner clip	steel				
2305*	1	inner clip	steel				
2330	1	adjusting ring	steel				
2335	1	adjusting ring	steel				
2390	1	gasket	rubber				
2400	1	name plate	stainless steel				

1) For pumps with semi - open impeller

2) For pumps with closed impeller

-- Material not specified

n/a Not applicable

**9.4 Pump FRE - bearing group 3**

9.4.1 Sectional drawing FRE - bearing group 3

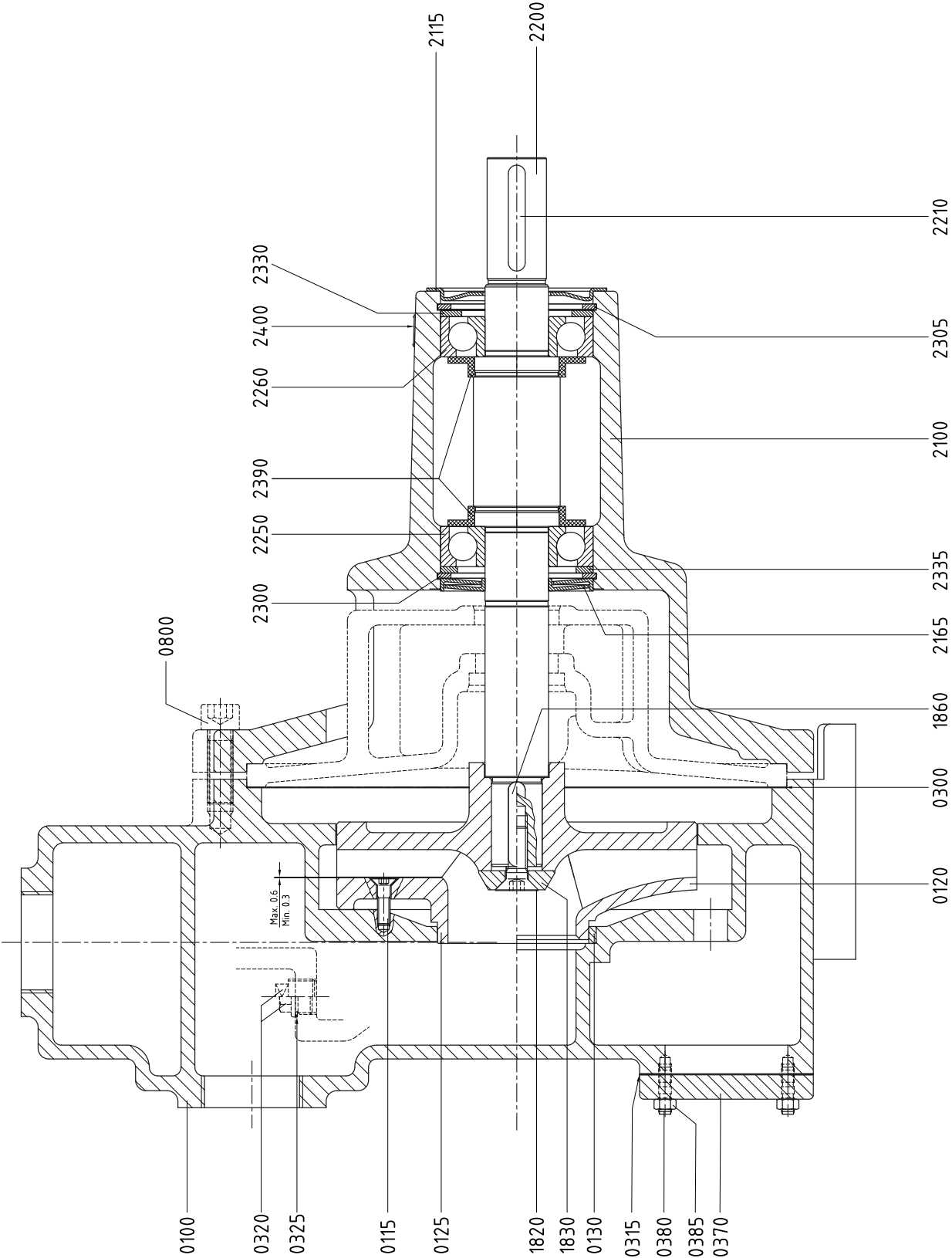

Figure 46: Sectional drawing FRE - bearing group 3.

9.4.2 Parts list FRE - bearing group 3

Item	Quantity	Description	Material				
			G1	G2	G6	B2	R6
0100	1	pump casing	cast iron			bronze	stainless steel
0115	2 <sup>1)</sup>	countersunk screw	stainless steel				
0120*	1	impeller	cast iron	bronze	stainless steel	bronze	stainless steel
0125*	1 <sup>1)</sup>	wear plate	cast iron		stainless steel	bronze	stainless steel
0130*	1 <sup>2)</sup>	wear ring	cast iron	bronze	stainless steel	bronze	stainless steel
0300*	1	gasket	--				
0315*	1 <sup>3)</sup>	gasket	--				
0320	1	plug	cast iron			stainless steel	
0325*	1	sealing ring	n/a				--
0370	1	cleaning cover	cast iron			stainless steel	
0380	4/6	stud	stainless steel				
0385	4/6	nut	stainless steel				
0800	6	Allen screw	steel				stainless steel
1820*	1	countersunk screw	stainless steel				
1830*	1	washer	stainless steel				
1860*	1	key	stainless steel				
2100	1	bearing bracket	cast iron				
2115	1	bearing cover	steel				
2165	1	sealing segment	steel				
2200*	1	pump shaft	stainless steel				
2210*	1	key	steel				
2250*	1	angular contact ball bearing	steel				
2260*	1	angular contact ball bearing	steel				
2300*	2	inner clip	steel				
2330	1	adjusting ring	steel				
2331	1	adjusting ring	steel				
2335	1	adjusting ring	steel				
2355*	1	waved washer	steel				
2390	2	gasket	rubber				
2400	1	name plate	stainless steel				

1) For pumps with semi - open impeller

2) For pumps with closed impeller

-- Material not specified

n/a Not applicable

## 9.5 Pump parts FRE 80-210 and 100-250

### 9.5.1 Sectional drawing FRE 80-210 and 100-250

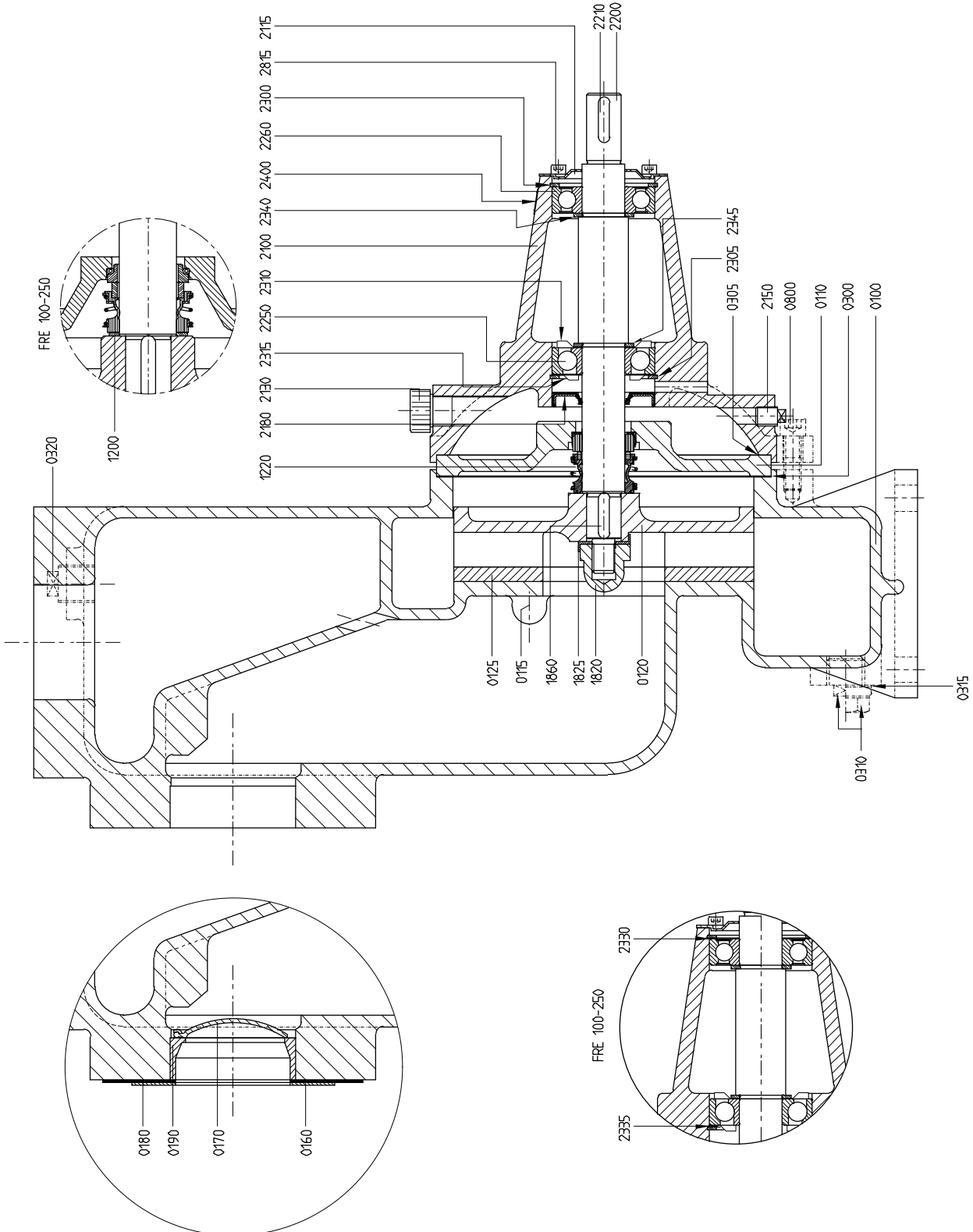

Figure 47: Sectional drawing FRE 80-210 and 100-250.

9.5.2 Parts list FRE 80-210 and 100-250

Item	Quantity	Description	Material			
			G1	G2	G6	R6 <sup>1)</sup>
0100	1	pump casing	cast iron		stainless steel	
0110	1	intermediate cover	cast iron		stainless steel	
0115	4	countersunk screw	stainless steel			
0120*	1	impeller	cast iron	bronze	stainless steel	
0125*	1	wear plate	steel		stainless steel	
0160	1 <sup>2)</sup>	gasket	rubber			
0170	1 <sup>2)</sup>	non-return valve	synthetic material			
0180	1 <sup>2)</sup>	spring plate	steel			
0190*	1 <sup>2)</sup>	valve seat	synthetic material			
0300*	1	gasket	--			
0305*	1	gasket	--			
0310	1	plug	steel		stainless steel	
0315	1 <sup>1)</sup>	sealing ring	--			
0320	1	plug	cast iron		stainless steel	
0800	8/12	Allen screw	steel		stainless steel	
1200	1 <sup>1)</sup>	distance sleeve	stainless steel			
1220*	1	mechanical seal	--			
1820*	1	cap nut	bronze		stainless steel	
1825*	1	lock plate	brass		n/a	
1860*	1	key	stainless steel			
2100	1	bearing bracket	cast iron			
2115	1	bearing cover	steel			
2130	1	filling plug	synthetic material		aluminium	
2150	1	oil drain plug	cast iron			
2180*	1	oil seal	--			
2200*	1	pump shaft	steel alloy		stainless steel	
2210*	1	key	steel			
2250*	1	angular contact ball bearing	--			
2260*	1	ball bearing	--			
2300*	1	inner circlip	steel			
2305*	1	inner circlip	steel			
2310*	1	NILOS-ring	steel			
2315*	1	NILOS-ring	steel			
2330	1 <sup>1)</sup>	adjusting ring	steel			
2335	1 <sup>1)</sup>	adjusting ring	steel			
2340	1	adjusting ring	steel			
2345	1	adjusting ring	steel			
2400	1	name plate	stainless steel			
2815	4	Allen screw	steel			

<sup>1)</sup> For FRE 100-250 only

<sup>2)</sup> For construction with suction valve only

-- Material not specified

n/a Not applicable

**9.6 Pump parts FRE 150-290b and 150-290**

**9.6.1 Sectional drawing FRE 150-290b and 150-290**

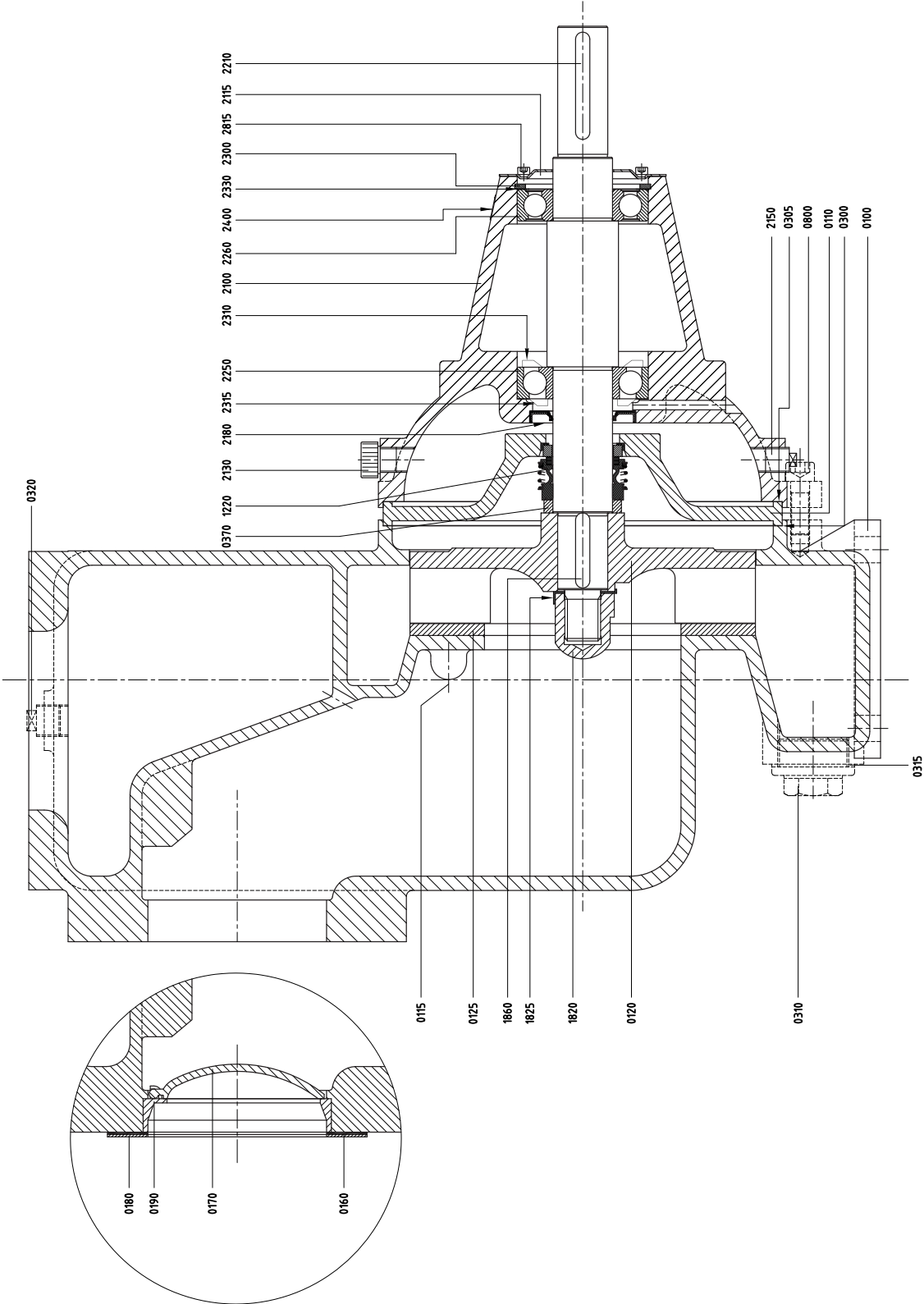

Figure 48: Sectional drawing FRE 150-290b and 150-290.

9.6.2 Parts list FRE 150-290b and 150-290

Item	Quantity	Description	Material			
			G1	G2	G6	R6
0100	1	pump casing	cast iron		stainless steel	
0110	1	intermediate cover	cast iron		stainless steel	
0115	4	countersunk screw	stainless steel			
0120*	1 <sup>1)</sup>	impeller	cast iron	bronze	stainless steel	
0125*	1	wear plate	steel		stainless steel	
0160	1 <sup>2)</sup>	gasket	rubber			
0170	1 <sup>2)</sup>	non-return valve	synthetic material			
0180	1 <sup>2)</sup>	spring plate	steel			
0190*	1 <sup>2)</sup>	valve seat	synthetic material			
0300*	1	gasket	--			
0305*	1	gasket	--			
0310	1	plug	steel		stainless steel	
0315*	1	sealing ring	--			
0320	1	plug	cast iron		stainless steel	
0800	8	Allen screw	steel		stainless steel	
1200	1	distance sleeve	stainless steel			
1220*	1	mechanical seal	--			
1820*	1	cap nut	bronze		stainless steel	
1825*	1	lock plate	brass		n/a	
1860*	1	key	stainless steel			
2100	1	bearing bracket	cast iron			
2115	1	bearing cover	steel			
2130	1	filling plug	synthetic material			
2150	1	oil drain plug	cast iron			
2180*	1	oil seal	--			
2200*	1	pump shaft	steel alloy		stainless steel	
2210*	1	key	steel			
2250*	1	angular contact ball bearing	--			
2260*	1	ball bearing	--			
2300*	1	inner circlip	steel			
2310*	1	NILOS-ring	steel			
2315*	1	NILOS-ring	steel			
2330	1	adjusting ring	steel			
2400	1	name plate	stainless steel			
2815	4	Allen screw	steel			

1) FRE 150-290b no G1 execution

2) For construction with suction valve only

-- Material not specified

n/a Not applicable

**9.7 Pump parts FRES**

**9.7.1 Sectional drawing FRES**

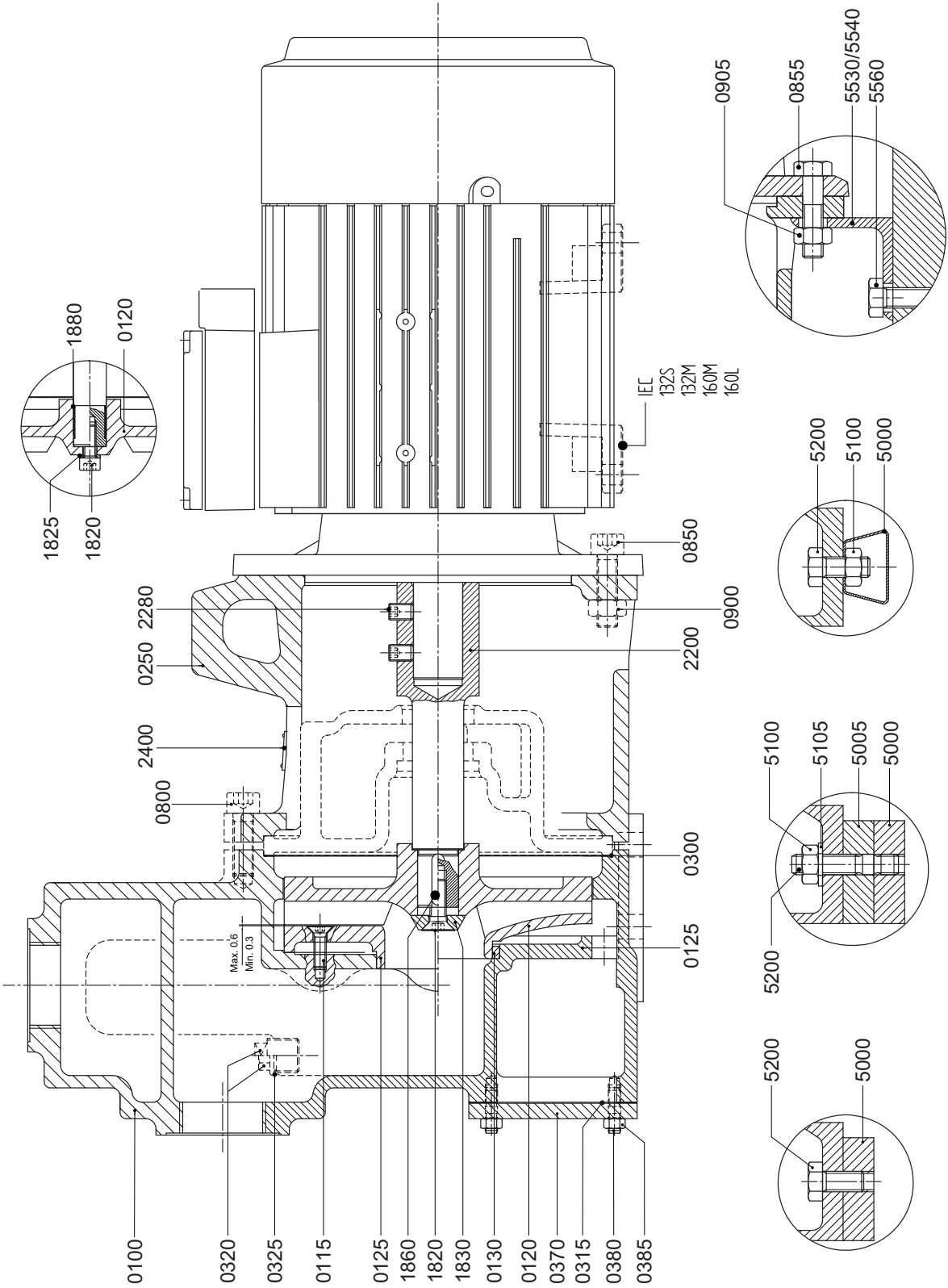

Figure 49: Sectional drawing FRES.



9.7.2 Parts list FRES

Item	Quantity	Description	Material				
			G1	G2	G6	B2	R6
0100	1	pump casing	cast iron			bronze	stainless steel
0115	2 <sup>1)</sup>	countersunk screw	stainless steel				
0120*	1	impeller	cast iron	bronze	stainless steel	bronze	stainless steel
0125*	1 <sup>1)</sup>	wear plate	cast iron		stainless steel	bronze	stainless steel
0130*	1 <sup>2)</sup>	wear ring	cast iron	bronze	stainless steel	bronze	stainless steel
0250	1	lantern piece	cast iron				
0300*	1	gasket	--				
0315*	1	gasket	--				
0320	1	plug	cast iron			stainless steel	
0325*	1	sealing ring	n/a				--
0370	1	cleaning cover	cast iron			bronze	stainless steel
0380	4/6	stud	steel				
0385	4/6	nut	steel				
0800	4/6	Allen screw	steel				stainless steel
0850	2/4	bolt	steel				
0855	2 <sup>5)</sup>	bolt	steel				
0900	2/4	nut	steel				
0905	4 <sup>5)</sup>	nut	steel				
1820*	1 <sup>3)</sup>	Allen screw	stainless steel				
1820*	1 <sup>4)</sup>	countersunk screw	stainless steel				
1825*	1 <sup>3)</sup>	spring washer	stainless steel				
1830*	1 <sup>4)</sup>	washer	stainless steel				
1860*	1 <sup>4)</sup>	key	stainless steel				
1880*	1 <sup>3)</sup>	tolerance ring	stainless steel				
2200*	1	stub shaft	stainless steel				
2280*	2	set screw	stainless steel				
2400	1	name plate	stainless steel				
5000	2 <sup>5)</sup>	uplift section (ANKRA profile)	steel				
5005	2 <sup>5)</sup>	elevation piece	steel				
5100	4 <sup>5)</sup>	nut	stainless steel				
5105	4 <sup>5)</sup>	washer	stainless steel				
5200	4 <sup>5)</sup>	bolt/stud	stainless steel				
5530	1 <sup>5)</sup>	support	steel				
5540	1 <sup>5)</sup>	support	steel				
5560	2 <sup>5)</sup>	bolt	stainless steel				

- 1) For pumps with semi - open impeller
- 2) For pumps with closed impeller
- 3) For bearing group 1
- 4) For bearing group 2 and 3
- 5) Assembly depends on pump and motor size
- Material not specified
- n/a Not applicable

## 9.8 Pump parts FREF

### 9.8.1 Sectional drawing FREF

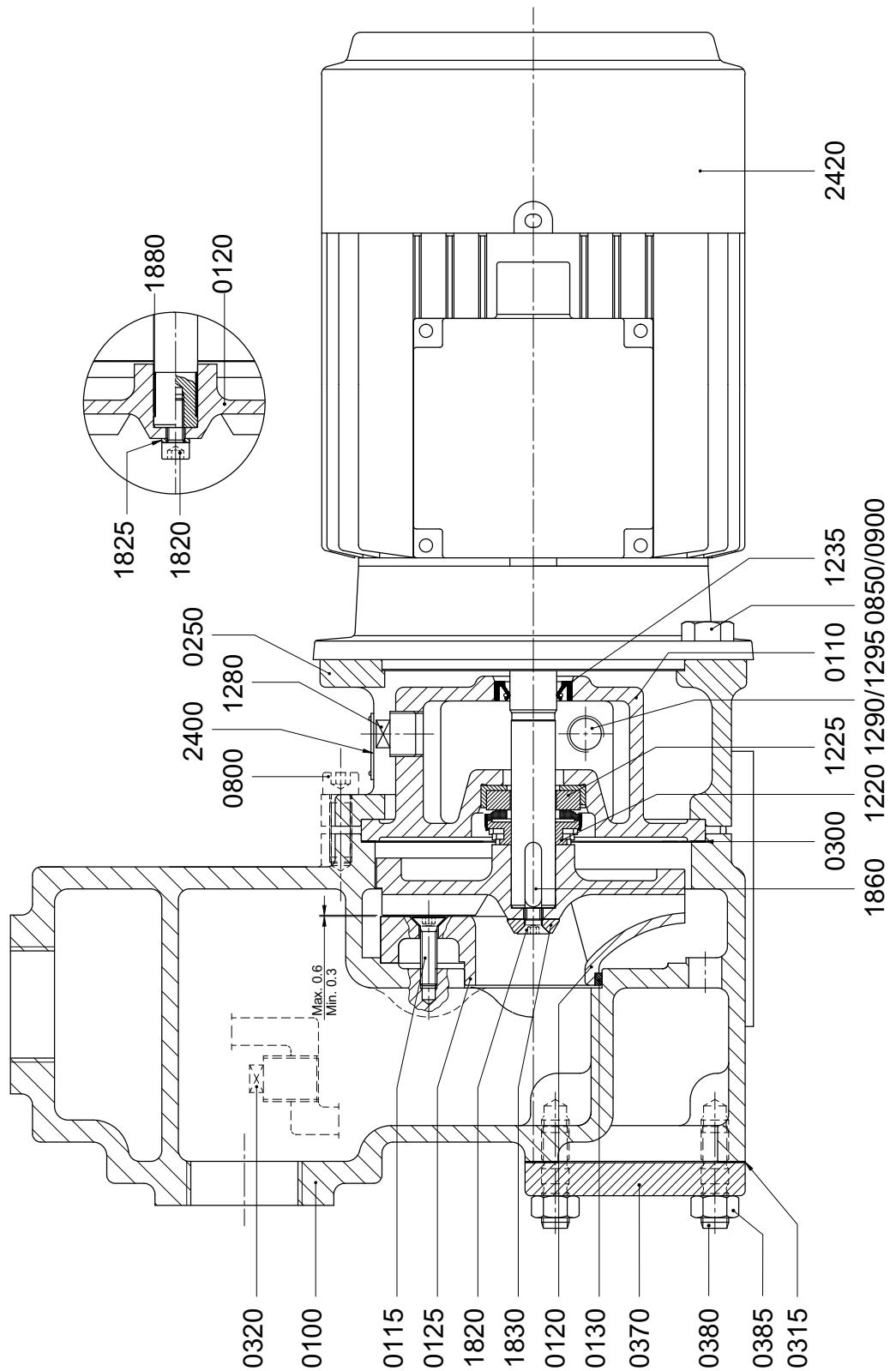

Figure 50: Sectional drawing FREF.

## 9.8.2 Parts list FREF

Item	Quantity	Description	Material
			G1
0100	1	pump casing	cast iron
0110	1	intermediate cover	cast iron
0115	2 <sup>1)</sup>	countersunk screw	stainless steel
0120*	1	impeller	cast iron
0125*	1 <sup>1)</sup>	wear plate	cast iron
0130*	1 <sup>2)</sup>	wear ring	cast iron
0250	1	lantern piece	cast iron
0300*	1	gasket	--
0315*	1	gasket	--
0320	1	plug	cast iron
0370	1	cleaning cover	cast iron
0380	4	stud	stainless steel
0385	4	nut	stainless steel
0800	4/6	Allen screw	steel
0850	4	bolt	steel
0900	4	nut	steel
1220*	1	slide ring	--
1225*	1	counter ring	--
1235*	1	oil seal	--
1280	1	plug	plastic
1290	1	plug	steel
1295	1	gasket	--
1820*	1 <sup>3)</sup>	Allen screw	stainless steel
1820*	1 <sup>4)</sup>	countersunk screw	stainless steel
1825*	1 <sup>3)</sup>	spring washer	stainless steel
1830*	1 <sup>4)</sup>	washer	stainless steel
1860*	1 <sup>4)</sup>	key	stainless steel
1880*	1 <sup>3)</sup>	tolerance ring	stainless steel
2400	1	name plate	stainless steel
2420	1	motor	steel

1) For pumps with semi - open impeller

2) For pumps with closed impeller

3) For bearing group 1

4) For bearing group 2

-- Material not specified



## 9.9.2 Parts list FREM

Item	Quantity	Description	Material
			G1
0100	1	pump casing	cast iron
0115	2 <sup>1)</sup>	countersunk screw	stainless steel
0120*	1	impeller	cast iron
0125*	1 <sup>1)</sup>	wear plate	cast iron
0130*	1 <sup>2)</sup>	wear ring	cast iron
0250	1	lantern piece	cast iron
0300*	1	gasket	--
0315*	1	gasket	--
0320	1	plug	cast iron
0370	1	cleaning cover	cast iron
0380	4	stud	stainless steel
0385	4	nut	stainless steel
0800	4/6	Allen screw	steel
0810	4/6	spring washer	steel
0850	4	bolt	steel
0865	4	spring washer	steel
1820*	1 <sup>3)</sup>	Allen screw	stainless steel
1820*	1 <sup>4)</sup>	countersunk screw	stainless steel
1825*	1 <sup>3)</sup>	spring washer	stainless steel
1830*	1 <sup>4)</sup>	washer	stainless steel
1860*	1 <sup>4)</sup>	key	stainless steel
1880*	1 <sup>3)</sup>	tolerance ring	stainless steel
2200	1	stub shaft	stainless steel
2280*	1	set screw	steel
2400	1	name plate	stainless steel
2420	1	combustion engine	--

1) For pumps with semi - open impeller

2) For pumps with closed impeller

3) For bearing group 1

4) For bearing group 2

-- Material not specified

## 9.10 Parts Mechanical seal MQ1

### 9.10.1 Sectional drawings Mechanical seal MQ1

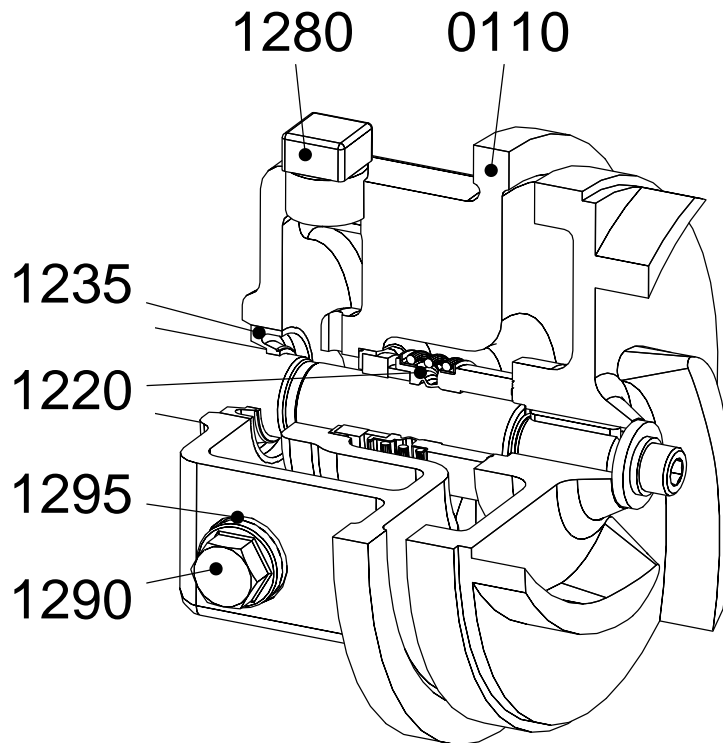

Figure 52: Sectional drawing Mechanical seal MG12.

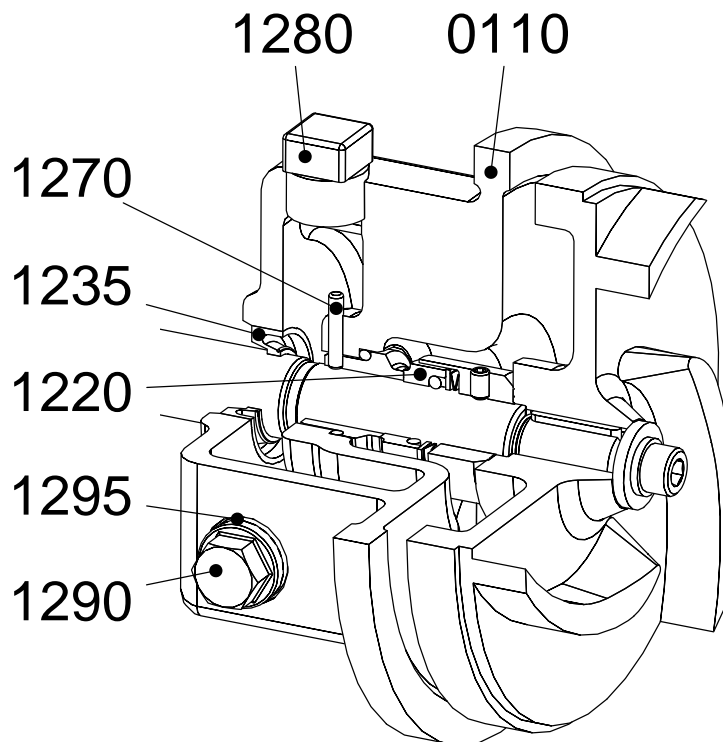

Figure 53: Sectional drawing Mechanical seal M7N.

## 9.10.2 Parts list Mechanical seal MQ1

Item	Quantity	Description	Material				
			G1	G2	G6	B2	R6
0110	1	intermediate cover	cast iron			bronze	stainless steel
1220	1	mechanical seal	--				
1235*	1	oil seal	--				
1270*	1 <sup>1)</sup>	locking pin	stainless steel				
1280	1	plug	plastic				
1290	1	plug	steel			stainless steel	
1295	1	sealing ring	--				

<sup>1)</sup> For M7N only

-- Material not specified

## 9.11 Parts FRE - plan 11

### 9.11.1 Sectional drawing FRE - plan 11

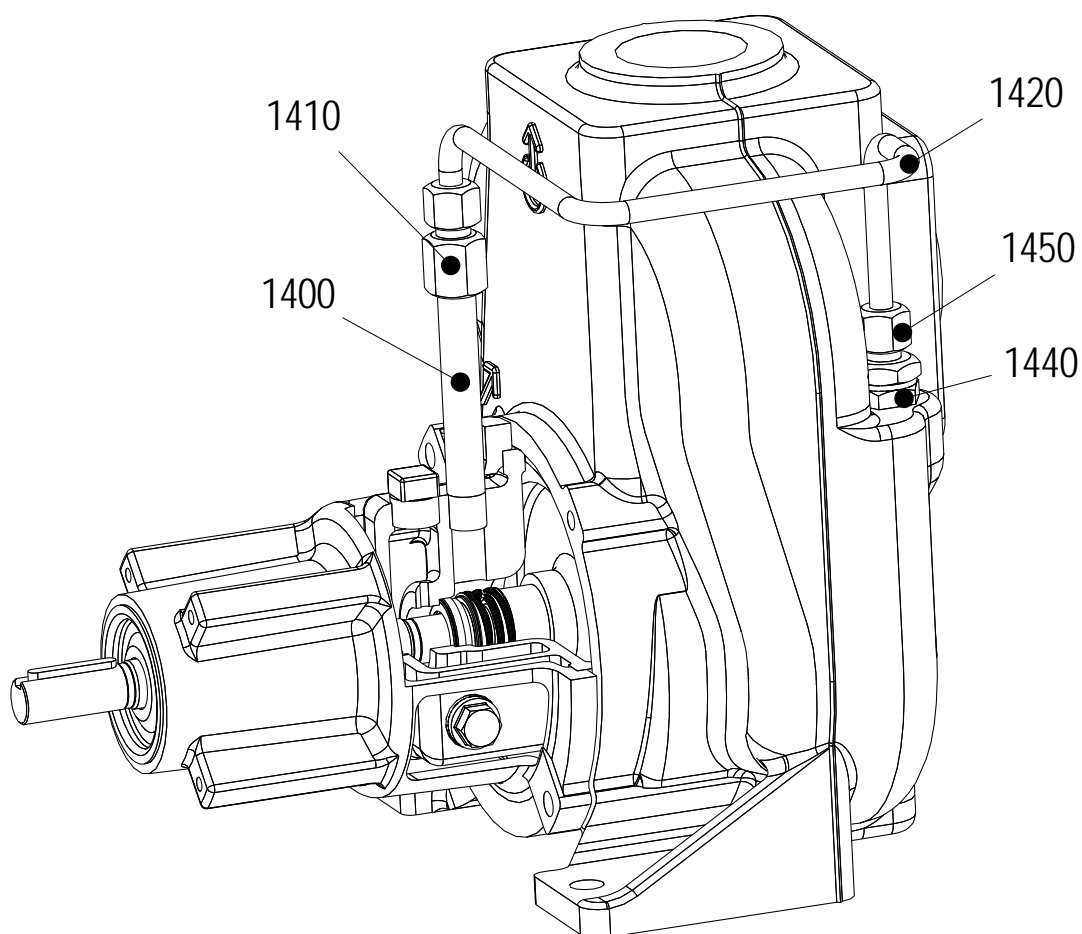

Figure 54: Sectional drawing FRE - plan 11.

### 9.11.2 Parts list FRE - plan 11

Item	Quantity	Description	Material				
			G1	G2	G6	B2	R6
1400	1	pipe nipple	stainless steel				
1410	1	pipe union	stainless steel				
1420	1	pipe	stainless steel				
1440	1	extension piece	stainless steel				
1450	1	male connector	stainless steel				

Item 1440 not for 32-110, 32-150, 40-110, 40-170, 50-205 and 65-230.



9.12 Parts Double mechanical seal MD1

9.12.1 Sectional drawing Double mechanical seal MD1

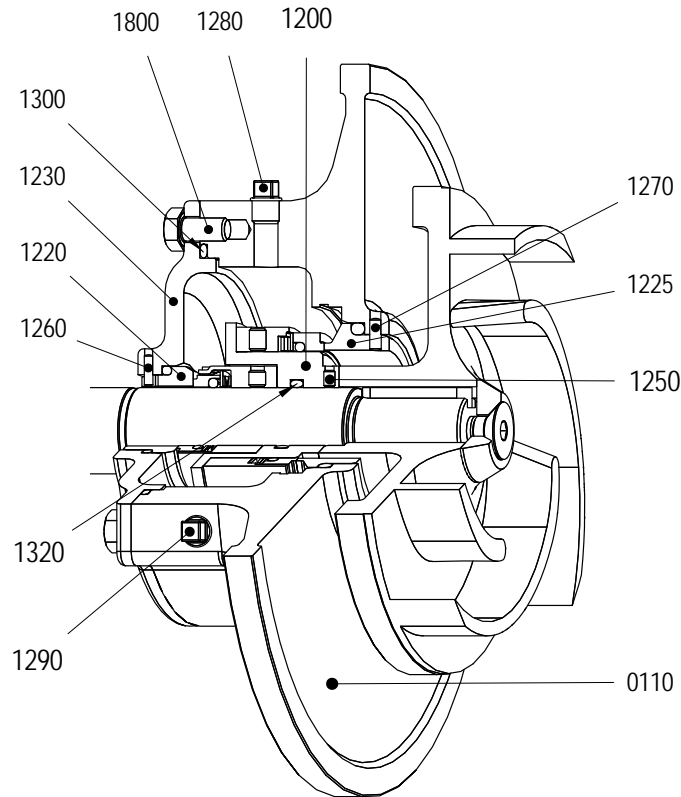

Figure 55: Sectional drawing Double mechanical seal MD1.

9.12.2 Parts list Double mechanical seal MD1

Item	Quantity	Description	Material			
			G1	G2	G6	R6
0110	1	intermediate cover	cast iron		stainless steel	
1200*	1	shaft sleeve	stainless steel			
1220*	1	mechanical seal	--			
1225*	1	mechanical seal	--			
1230	1 <sup>1)</sup>	mechanical seal cover	cast iron		stainless steel	
1250	2	set screw	stainless steel			
1260	1	locking pin	stainless steel			
1270	1	locking pin	stainless steel			
1280	1	plug	cast iron		stainless steel	
1290	1	plug	cast iron		stainless steel	
1300*	1	O-ring	--			
1320*	1	O-ring	--			
1800	3	bolt	stainless steel			

<sup>1)</sup> Bearing group 1 : G1, G2 and G6 configuration is the same as R6

-- Material not specified

## 9.13 Parts Cutting mechanism

### 9.13.1 Sectional drawing Cutting mechanism

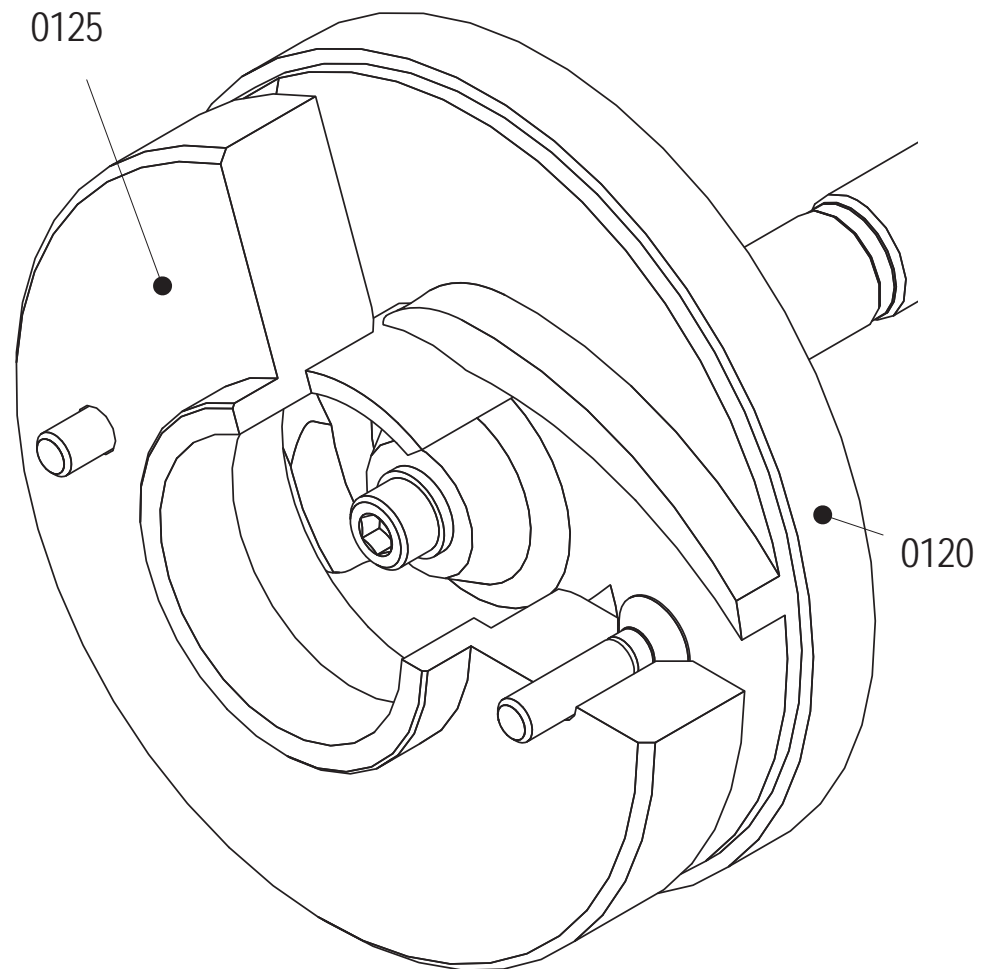

Figure 56: Sectional drawing Cutting mechanism.

### 9.13.2 Parts list Cutting mechanism

Item	Quantity	Description	Material	
			G6	R6
0120*	1	impeller	stainless steel	
0125*	1	wear plate	stainless steel	

## 10 Technical data

### 10.1 Oil chamber

Table 8: Recommended oil type: SAE 20.

Oil contents		Pump types
MQ0/MQ1	MD1	
0,06 litre	0,033 litre	32-110 and 40-110
0,15 litre	0,06 litre	32-150, 50-125b, 50-125, 65-135, 65-155 and 80-140
0,29 litre	0,22 litre	40-170, 50-205, 65-230, 80-170, 100-225b and 100-225
0,57 litre	--	80-210
1,2 litre	--	100-250
2,5 litre	--	150-290b and 150-290

### 10.2 Recommended locking liquids

Table 9: Recommended locking liquids.

Description	Locking liquid
locking of the impeller bolt	Loctite 243
set screws of the stub shaft	
fastening screws FREM	
securing the stub shaft onto the motor shaft of the FREM	Loctite 648
securing the wear ring in the pump casing on closed impeller pumps	Loctite 641
sealing the tolerance ring of stainless steel and bronze pumps	Loctite 572

### 10.3 Tightening moments

#### 10.3.1 Tightening moments for bolts and nuts

Table 10: Tightening moments for bolts and nuts.

Materials	8.8	12.9	A2, A4
Thread	Tightening moment [Nm]		
M6	11	17	8,5
M8	25	41	21
M10	51	83	42
M12	87	150	70
M16	215	370	173
Application	bearing bracket / lantern piece	set screws	impeller / wear plate

## 10.3.2 Tightening moments set screw from coupling

*Table 11: Tightening moments set screw from coupling.*

<b>Size</b>	<b>Tightening moment [Nm]</b>
M6	4
M8	8
M10	15
M12	25
M16	70

10.4 Hydraulic performance

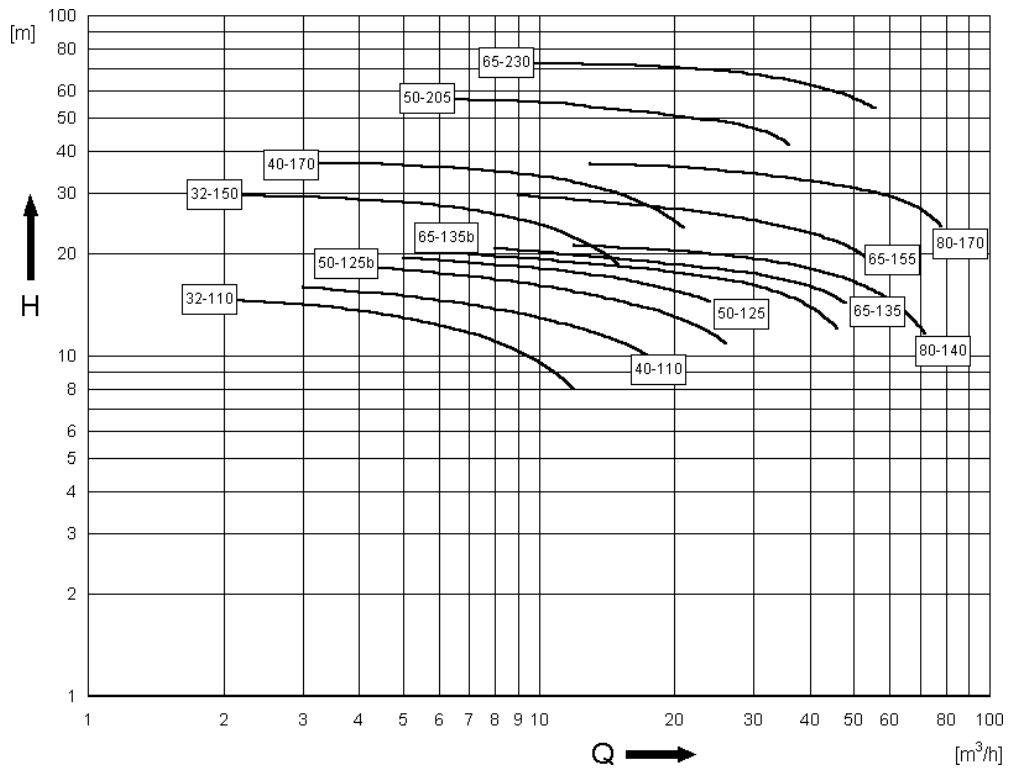

Figure 57: Performance overview 3000 min<sup>-1</sup>.

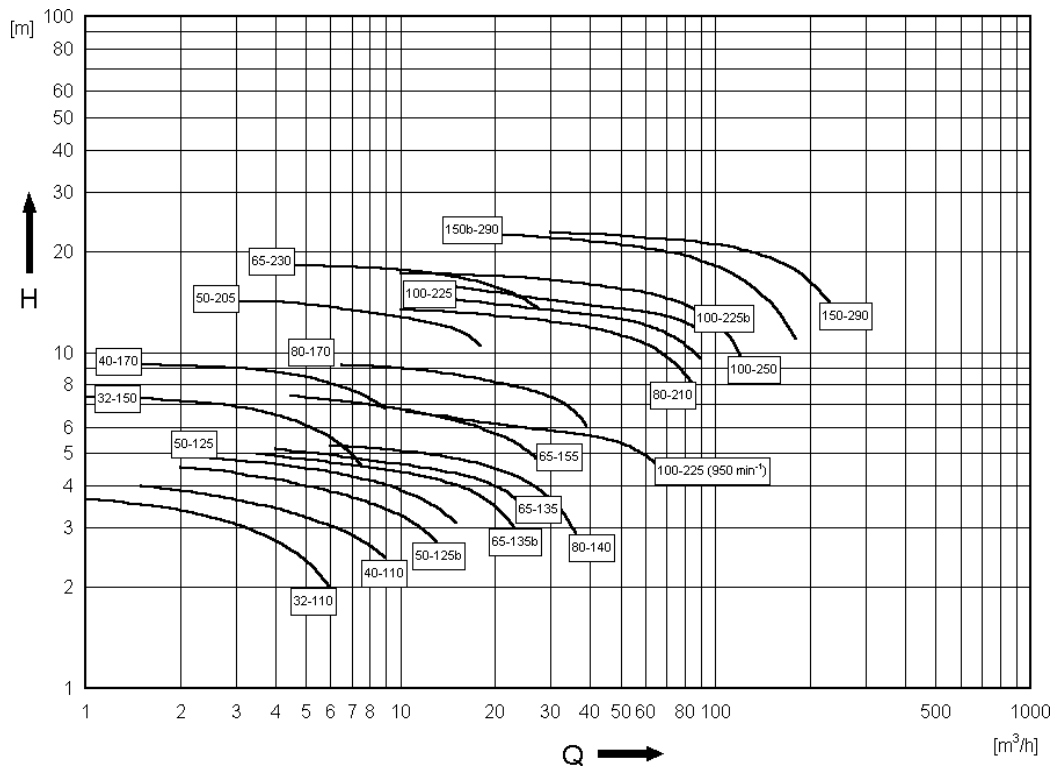

Figure 58: Performance overview 1500 min<sup>-1</sup>.

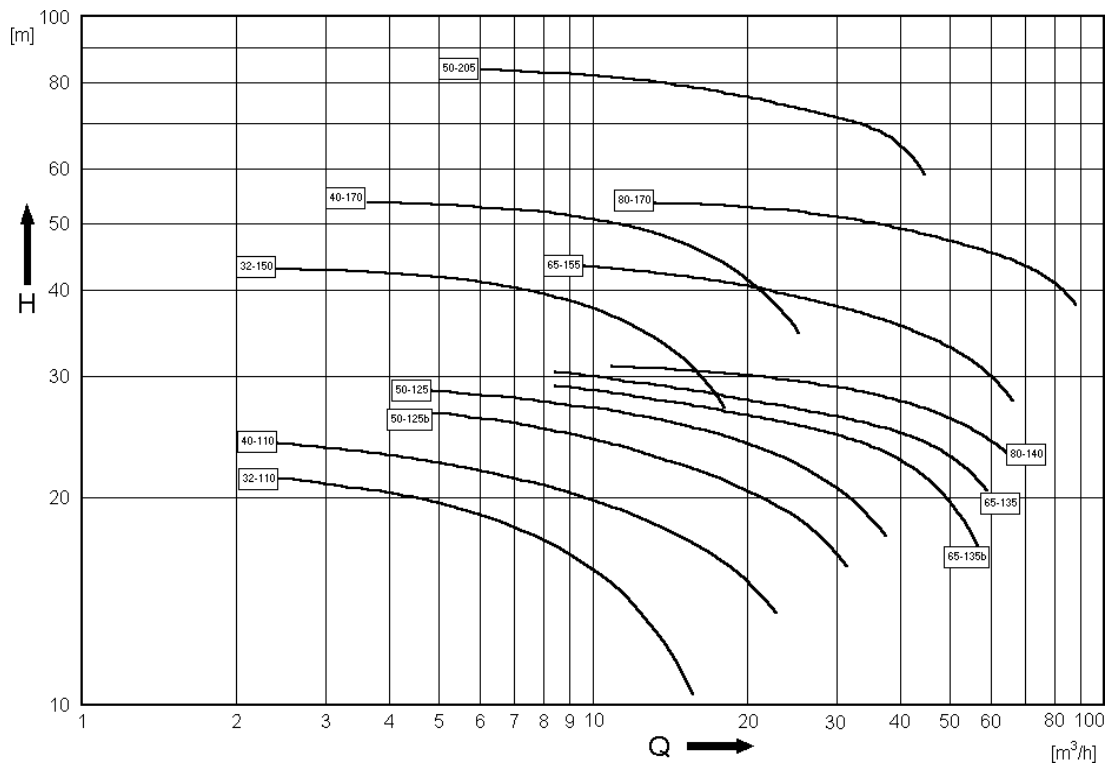

Figure 59: Performance overview 3600 min<sup>-1</sup>.

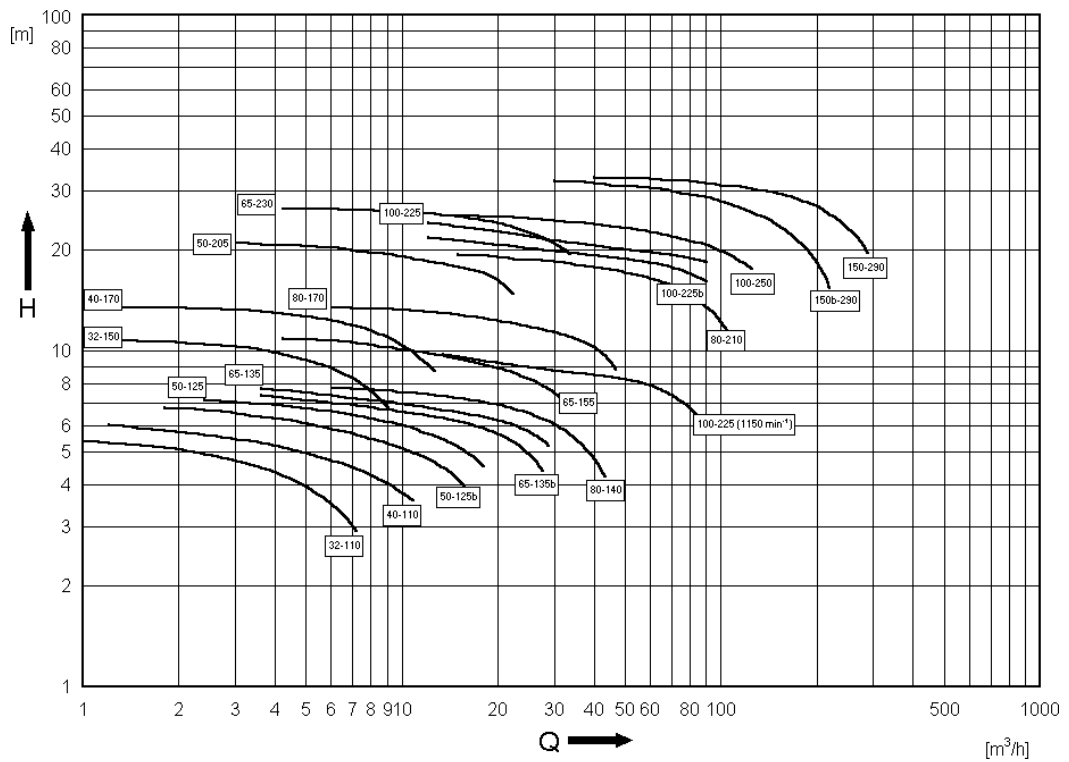

Figure 60: Performance overview 1800 min<sup>-1</sup>.

**10.5 Permissible forces and moments on the flanges**

The forces and torques acting on the flanges cause deformations in the pump unit. These are manifested in a displacement of the shaft journal of the pump in relation to the shaft journal of the motor. The permissible forces and moments on the flanges should be based on the following maximum values for the radial displacement of the shaft journal of the pump:

- pumps of bracket group 1: 0,15 mm,
- pumps of bracket group 2: 0,20 mm,
- pumps of bracket group 3: 0,25 mm,
- pumps of bracket group 4: 0,25 mm.

When determining the forces the weight of the piping and of the liquid must be taken into account.

Irrespective of the direction of the forces and torques and their components on the flanges, the permissible values should comply with the following equation:

$$\left(\frac{F_v}{F_{v, \max}}\right)^2 + \left(\frac{F_h}{F_{h, \max}}\right)^2 + \left(\frac{M}{M_{\max}}\right)^2 \leq 1$$

$F_v = 2/3 \cdot F_{v, \text{press}} + F_{v, \text{suct}} \leq F_{v, \max}$  Index **v** = in vertical direction, **y axis**

$F_h = F_{h, \text{press}} + 2/3 \cdot F_{h, \text{suct}} \leq F_{h, \max}$  Index **h** = in horizontal direction, **x axis and z axis**

$M = M_{\text{press}} + M_{\text{suct}} \leq M_{\max}$  **M** = torque in the plane of the flange

$F_{v, \max}$ ,  $F_{h, \max}$  and  $M_{\max}$  are given in the table. A distinction is made here between a pump unit with a base plate **not grouted** and a pump unit with a base plate which **is grouted**

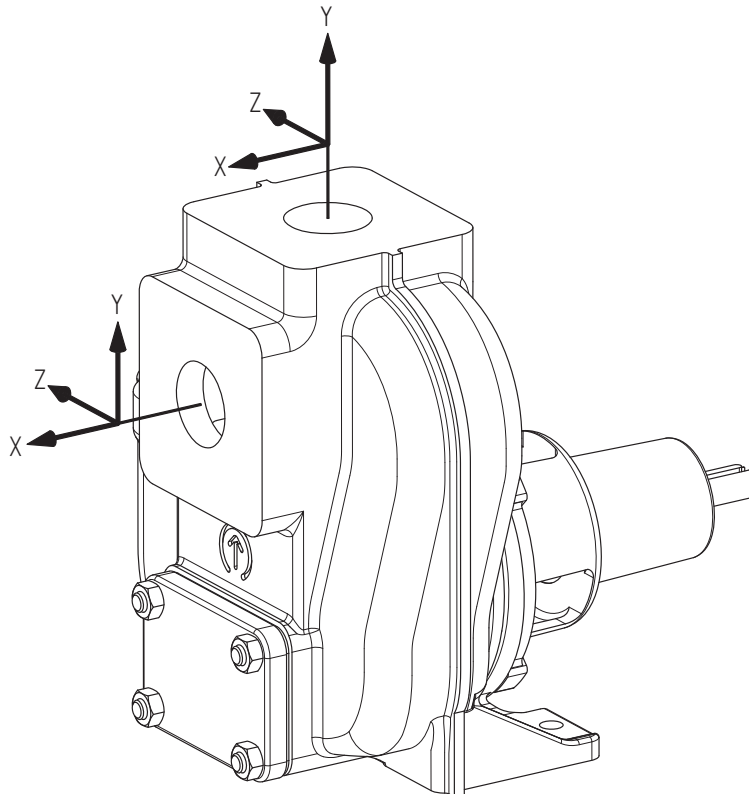

Table 12: Permissible forces and moments on the flanges, based on EN-ISO 5199

FRE	Bracket group	Pump unit, non grouted base plate			Pump unit, grouted base plate		
		$F_v \text{ max}$ [N]	$F_h \text{ max}$ [N]	$M_{\text{max}}$ [Nm]	$F_v \text{ max}$ [N]	$F_h \text{ max}$ [N]	$M_{\text{max}}$ [Nm]
32-110	1	1250	950	175	2250	1500	450
32-150	2	1250	950	150	2250	1500	425
40-110	1	1450	1050	250	2550	1800	625
40-170	3	1300	975	200	2300	1600	500
50-125b	2	1450	1050	250	2550	1800	625
50-125	2	1450	1050	250	2550	1800	625
50-205	3	1400	1000	275	2500	1750	650
65-135b	2	1850	1250	475	3250	2500	1200
65-135	2	1850	1250	475	3250	2500	1200
65-155	2	1500	1050	325	2800	2100	850
65-230	3	1750	1200	450	3200	2400	1125
80-140	2	1650	1050	400	3000	2300	1000
80-170	3	1950	1250	500	3400	2550	1225
80-210	4	3300	2000	1050	5445	3300	1730
100-225b	3	3100	1850	900	4750	3900	2175
100-225	3	3100	1850	900	4750	3900	2175
100-250	4	3600	2200	1250	6120	3740	2125
150-290b	4	3500	2100	1130	6090	3654	1970
150-290	4	3500	2100	1130	6090	3654	1970

Pump casing material:

Cast iron	stated values x 1,0
Stainless steel	stated values x 2,0



10.6 Noise data

10.6.1 Pump noise as a function of pump power

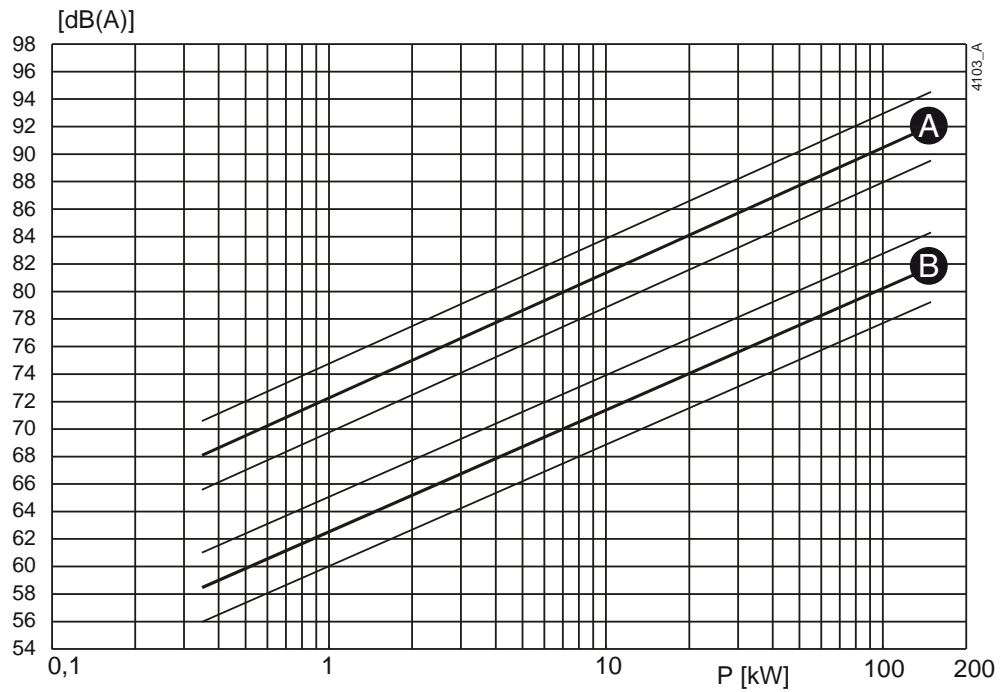

Figure 61: Noise level as function of pump power [kW] at  $1450 \text{ min}^{-1}$   
 A = sound power level, B = sound pressure level.

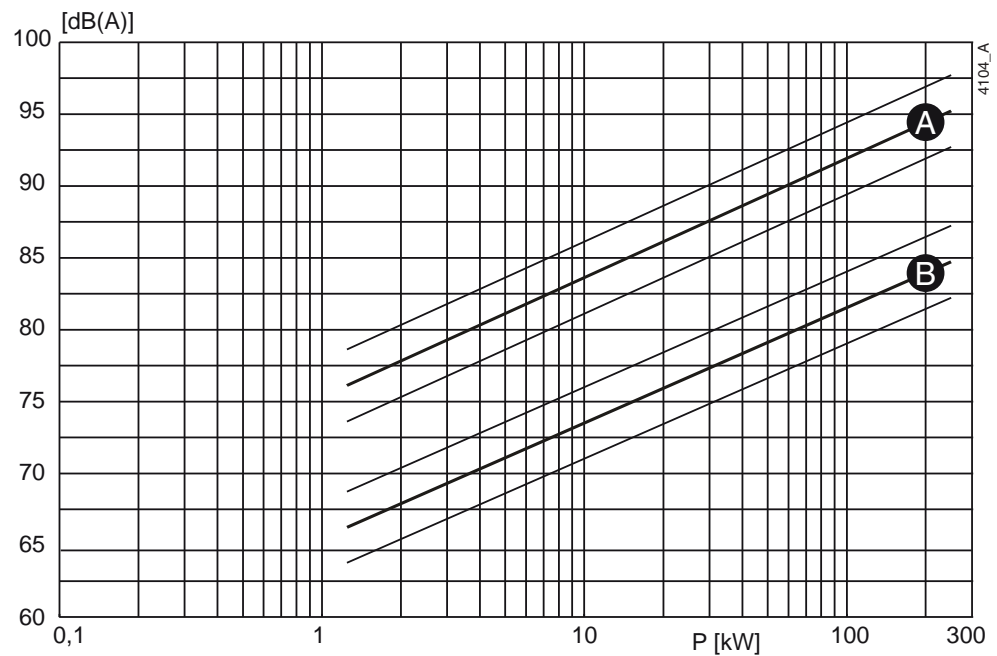

Figure 62: Noise level as function of pump power [kW] at  $2900 \text{ min}^{-1}$   
 A = sound power level, B = sound pressure level.

## 10.6.2 Noise level of entire pump unit

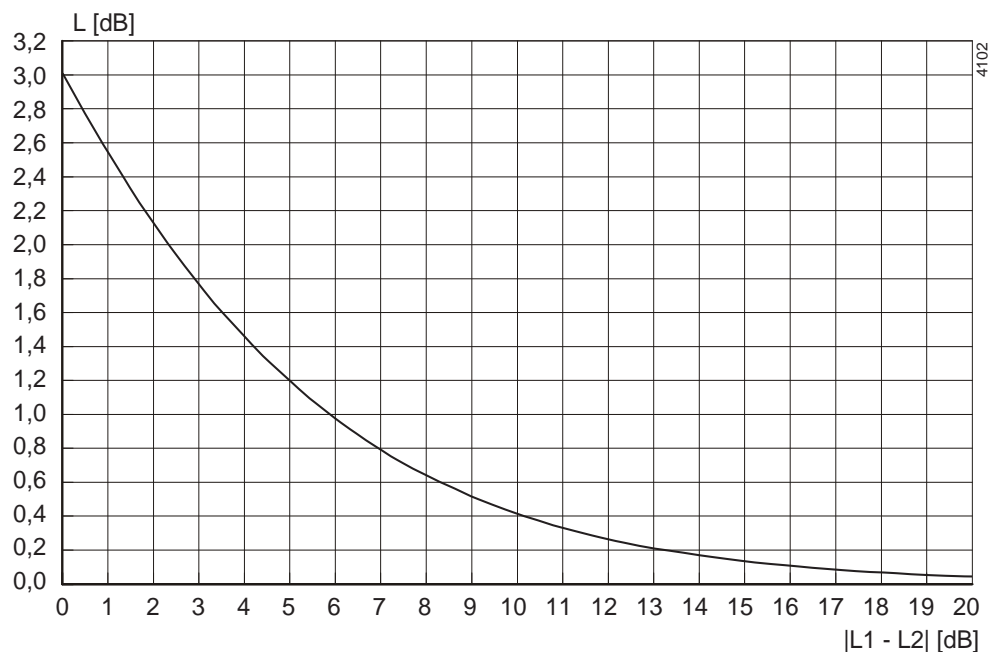

Figure 63: Noise level of entire pump unit.

In order to determine the total noise level of the entire pump unit, the noise level of the motor must be added to that of the pump. This can be easily done by using the graph above.

- 1 Determine the noise level (L1) of the pump, see figure 61 or figure 62.
- 2 Determine the noise level (L2) of the motor, see documentation of the motor.
- 3 Determine the difference between both levels  $|L1 - L2|$ .
- 4 Find the differential value on the  $|L1 - L2|$ -axis and go up to the curve.
- 5 From the curve go left to the L[dB] -axis and read out the value.
- 6 Add this value to the highest value of both noise levels (L1 or L2).

Example:

- 1 Pump 75 dB; motor 78 dB.
- 2  $|75-78| = 3$  dB.
- 3 3 dB on the X-axis = 1,75 dB on the Y-axis.
- 4 Highest noise level + 1,75 dB =  $78 + 1,75 = 79,75$  dB.

# Index

## A

Application area .....17

## B

Back Pull Out-unit  
     assembly .....32  
     disassembly .....32  
 Back-Pull-Out system .....32  
 Bearing .....42  
 Bearing groups .....14  
 Bearings  
     assembly instructions .....42  
     disassembly instructions .....42

## C

Combustion engine .....23  
     safety .....23  
     sense of rotation .....23  
 Commissioning .....25  
 Connections .....17  
 Construction variants .....31  
 Coupling  
     alignment .....20  
     alignment tolerances .....21

## D

Daily maintenance .....27  
     double mechanical seal .....27  
     mechanical seal .....27  
 Draining .....31  
     liquid .....31

## E

Electric motor  
     connection .....23  
 Environment .....19

## F

Faults .....28  
 Fax-order form .....12

## G

Guard  
     assembly .....32  
     disassembling .....32

## H

Hoisting .....11

## I

Impeller  
     replacement .....35  
 Inspection  
     motor .....25  
     pump .....25

## L

Lifting eye .....11

## M

Maintenance staff .....9  
 Mechanical seal .....39  
     assembly instructions .....39  
 Mechanical seal M7N  
     assembly .....40  
     disassembly .....40  
 Mechanical seal MD1  
     assembly .....41  
     disassembly .....41  
 Mechanical seal MG12  
     assembly .....39  
     disassembly .....39

## N

Noise .....26, 28

## O

Oil chamber .....25  
     oil contents .....97  
 Order instructions .....12  
 Ordering parts .....12

<b>P</b>	
Piping .....	22
Precautionary measures .....	31
Preservation .....	19
Pump description .....	13
Pump unit	
assembly .....	20
installation .....	20
<b>R</b>	
Re-use .....	17
<b>S</b>	
Safety .....	19
symbols .....	9
Scrapping .....	17
Sense of rotation .....	25
Serial number .....	14
Special tools .....	31
Start-up .....	26
Static electricity .....	19
Storage .....	10, 11, 12
<b>T</b>	
Technicians .....	9
Tightening moments	
for bolts and nuts .....	97
set screw coupling .....	98
Transport .....	10
Type code .....	13
<b>W</b>	
Wear ring	
assembly .....	38
disassembly .....	38
replacement .....	35
Working switch .....	23





FreFlow

Horizontal centrifugal pump

**SPXFLOW**

SPX Flow Technology Assen B.V.  
Dr. A. F. Philipsweg 51, 9403 AD Assen, THE NETHERLANDS  
Phone: + 31 (0) 592 37 67 67 Fax: + 31 (0) 592 37 67 60  
E-Mail: [johnson-pump.nl@spxflow.com](mailto:johnson-pump.nl@spxflow.com)  
[www.spxflow.com/johnson-pump](http://www.spxflow.com/johnson-pump)  
[www.spxflow.com](http://www.spxflow.com)

For more information about our worldwide locations, approvals, certifications, and local representatives, please visit [www.spxflow.com/johnson-pump](http://www.spxflow.com/johnson-pump).

SPXFLOW Corporation reserves the right to incorporate our latest design and material changes without notice or obligation. Design features, materials of construction and dimensional data, as described in this bulletin, are provided for your information only and should not be relied upon unless confirmed in writing.

ISSUED 12/2015  
Copyright © 2015 SPXFLOW Corporation