

OPERATING AND INSTALLATION INSTRUCTIONS



**Air-Operated Double
Diaphragm Pumps
made of Plastic**

**E-Series
E 08 - E 50**



Original Instruction
Read carefully before pump installation

	Page
Introduction	3
General description of the machine, appropriate use and residual dangers	3
Storage	3
Codesystem	4
Operation in explosion proof areas	5
Technical data	5
Performance charts	6
Installation	
Recommended installation	8
Product ports	8
Startup operations	9
Torque values	10
Safety instructions	10
Using as submersible pump	11
Additional temperature hints	12
Providing spare parts	12
Maintenance	
Required tools	13
Disassembly	13
Assembly	15
Trouble shooting	16
Spare part lists	
Code EEE – ETZ	18
Code TEE – TTZ	19
Code FEE – FTZ	20
Code UEE – UTZ	21
Exploded views	
E 08 / E 10	22
E 15 / E 25 / E 40 / E 50	23
Optional equipment	
Stroke counting (code C)	24
Diaphragm monitoring (D)	25
Special diaphragms (L+P)	26
ANSI connections (W)	26
Flange connections (F)	27
Pumps for food contact (H)	27
Damper preparation (TV)	27
Draining system (R)	28
FKM housing gaskets (V)	29
External control (Z)	29
More options	29
Dimensions drawing	30
Pulsation dampe ET/ET-F	31

INTRODUCTION

ALMATEC air-operated diaphragm pumps are constructed according to the state of the art and they are reliable. Imminent danger by operating error or misuse can lead to damages of properties and/or persons. The pumps are to be applied for the intended use and in a safety-related proper condition only.

Each person working on the ALMATEC air-operated diaphragm pumps concerning installation, start-up, handling or maintenance has to read this manual completely and in an attentive way and has to follow all mentioned procedures and safety notes.

GENERAL DESCRIPTION OF THE MACHINE, APPROPRIATE USE AND RESIDUAL DANGERS

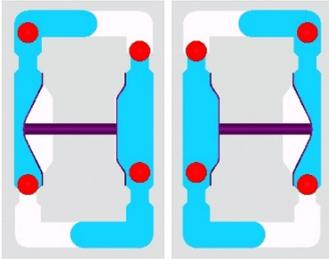

The ALMATEC E-Series pumps are oscillating positive displacement pumps and are based on the functional principle of double diaphragm pumps. The basic configuration consists of two external side housings with a center housing between them. Each of the side housings contains a product chamber which is sealed against the center housing by a diaphragm. The two diaphragms are interconnected by a piston rod. Directed by an air control system, the diaphragms are alternately loaded with compressed air so that they move back and forth. In the first figure, the compressed air has forced the left-hand diaphragm towards the product chamber and displaced the liquid from that chamber through the open valve at the top to the discharge port. Liquid is simultaneously drawn in by the right-hand diaphragm, thus refilling the second product chamber. When the end of the stroke is reached, it reverses automatically and the cycle is repeated in the opposite direction. In the second figure, liquid is drawn in by the left-hand diaphragm and displaced by the right-hand diaphragm.

The appropriate use of an Almatec air-operated diaphragm pump of the E-Series refers to the liquid transport taking into account the operation parameter mentioned in this manual and in compliance of the given terms for commissioning, operation, assembly, disassembly and maintenance.

Even if all necessary safety measures described in this manual have been met, a residual danger exists by leakages or mechanical damages. At sealing areas or connections liquid can be released uncontrollably then.

STORAGE

In general the ALMATEC pump is delivered operational and packaged. If the unit is not installed right away, proper storage conditions are important for a trouble free operation later. The pump has to be protected from wetness, coldness, dirtying, UV-radiation and mechanical influences. The following storage conditions are recommended:

- Steady ventilated, dust and vibration free storage room
- Ambient temperature between 15°C (59°F) and 25°C (77°F) with a relative humidity below 65%
- Prevention of direct thermal influences (sun, heating)

CODESYSTEM

The ALMATEC Maschinenbau GmbH is certified as a modern, quality-orientated enterprise according to DIN EN ISO 9001:2008 and 14001:2005. Before release for dispatch, any pump of the E-Series has to undergo an extended final control. The performance data registered during this are archived in our records and can be read back at any time.

As a general rule in the countries of the EU only such machines are allowed to take into operation, which are determined to meet the regulations of the EU machinery directive, the harmonized standards, European standards and the respective national standards. Hence the operator has to verify whether the ALMATEC pump manufactured and delivered properly according to the customer's order meets the mentioned requirements.

Therefore make sure, before putting the pump into operation, that the pump and the used materials of construction are suitable for the provided application and the installation site. To check this, the exact pump code is required. This code, the serial number and the year of construction are noted on the identification plates on the pump itself.

Example to clarify the ALMATEC pump code:

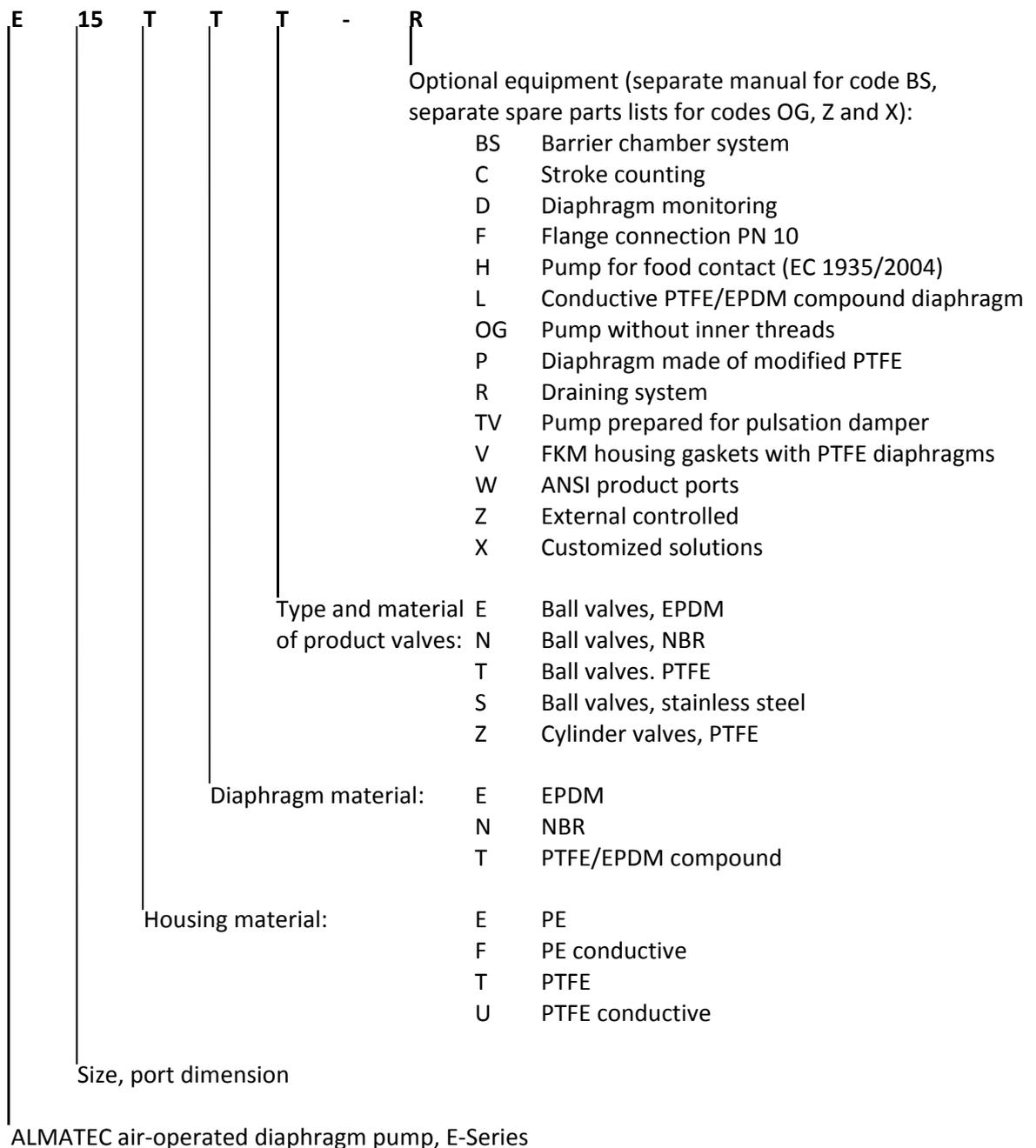

The number in brackets, which is added to every part mentioned in the following explanations, refers to its position in the spare part list and the exploded view.



For flammable liquids as well as for applications in explosion-proof areas, only pumps with housings and fittings in conductive plastic materials may be used. AODD pumps of the E-Series with the housing codes F (PE conductive) and U (PTFE conductive) meet this requirement. The pump has to be grounded. A connection to ground the pump is included in the center housing [4]. All other housing parts are connected to the center housing; therefore it is not necessary to ground single parts.

ALMATEC E-Series pumps made of electrically conductive PE/PTFE are suitable to be used in explosion areas of the category 2 and 3, atmosphere G/D, which are liable to the 94/9/EG. Conductive diaphragms (liquid side) are applicable without restrictions for

transferring liquids of any explosion-group.

When using non-conductive diaphragm materials, the following exemplary protection measures have to be respected:

- The pump is always used for the transfer of exclusively fluids which are conductive or soluble in water or
- Dry-running is avoided by action steps within the facility and/or its control or
- The system is inertised in case of dry running by nitrogen, water, carbon dioxide etc. when the fluid transfer ends.

Piping systems and product connections have to be grounded separately. To avoid ignition hazards the formation of dust deposits on the pumps must be prevented. In explosion proof areas repair working only after careful inspection of the practicability and only with appropriate tools. For the ATEX marking according to 94/9/EG please see the attached conformity declaration and the according pump label.

TECHNICAL DATA		E 08	E 10	E 15	E 25	E 40	E 50
Dimensions, mm (in.):	length	88 (3.5)	110 (4.3)	166 (6.5)	220 (8.7)	304 (12.0)	399 (15.7)
	width	128 (5.0)	147 (5.8)	189 (7.4)	255 (10.0)	353 (13.9)	430 (16.9)
	height	129 (5.1)	169 (6.7)	240 (9.4)	320 (12.6)	432 (17.0)	552 (21.7)
Nominal port size	NPT	1/4"	3/8"	1/2"	1"	1 1/2"	2"
Air connection	BSP	R 1/8	R 1/8	R 1/4	R 1/4	R 1/2	R 1/2
Weight, kg (lb):	PE	-	-	7 (15)	15 (33)	34 (75)	66 (146)
	PTFE	2 (4)	5 (11)	12 (26)	29 (64)	69 (152)	131 (289)
Max. particle size of solids for pumps with ball valves	mm (in.)	2 (0.08)	3 (0.12)	4 (0.16)	6 (0.24)	9 (0.35)	11 (0.43)
Suction lift dry, mWC (ft):	cylinder valves	1 (3.3)	2 (6.6)	3 (9.8)	4 (13.1)	5 (16.4)	5 (16.4)
	ball valves	0,4 (1.3)	1 (3.3)	2 (6.6)	3 (9.8)	4 (13.1)	4 (13.1)
Suction lift wet, mWC (ft)		9 (29.5)	9 (29.5)	9,5 (31.2)	9,5 (31.2)	9,5 (31.2)	9,5 (31.2)
Max. driving and operating pressure, bar (psig)		7 (100)	7 (100)	7 (100)	7 (100)	7 (100)	7 (100)
Max. operating temperature, °C (F):	PE	-	-	70 (158)	70 (158)	70 (158)	70 (158)
	PTFE*	100 (212)	100 (212)	120 (248)	120 (248)	120 (248)	120 (248)
Theoretical displacement volume per single stroke (l)		0,0075	0,0215	0,1	0,34	0,98	2,6
Sound power level L_{WA} [dB (A)]:**	driving pressure 3 bar	77,5-84,0	79,5-81,0	77,0-89,0	74,0-84,2	82,2-86,6	66,6-84,9
	driving pressure 5 bar	80,0-86,5	79,5-85,0	75,0-94,0	68,6-87,8	72,2-95,5	73,5-91,5
	driving pressure 7 bar	80,2-87,0	79,5-86,0	74,0-96,0	70,0-91,0	68,5-94,4	67,3-96,0
Sound pressure level L_{pfr} , 1 m [dB (A)]:***	driving pressure 3 bar	64,1-70,3	65,9-67,5	63,2-74,9	61,7-71,9	69,5-73,9	53,4-71,7
	driving pressure 5 bar	66,2-73,1	65,7-70,8	60,9-80,1	56,3-75,5	59,5-82,8	60,3-78,3
	driving pressure 7 bar	66,8-73,8	65,7-72,1	60,3-82,0	57,7-78,8	55,8-81,7	54,1-82,8

* PTFE pumps with NBR equipment 80°C (176°F)

** determined in sound power level measurements according to EN ISO 3744 respectively EN ISO 9614 in laboratory and practise conditions

*** sound pressure levels as average location-independent values calculated norm-conformous from the location of the sound power levels listed above

These technical data refer to ALMATEC E-Series pumps without optional equipment.

PERFORMANCE CHARTS

The data refer to water (20°C/68°F), under using of different variations (e.g. ball valve model, damper preparation etc.), a compressor Atlas Copco VSG30 and calibrated measuring equipment. The specified performance data are warranted by ALMATEC in accordance with DIN EN ISO 9906.

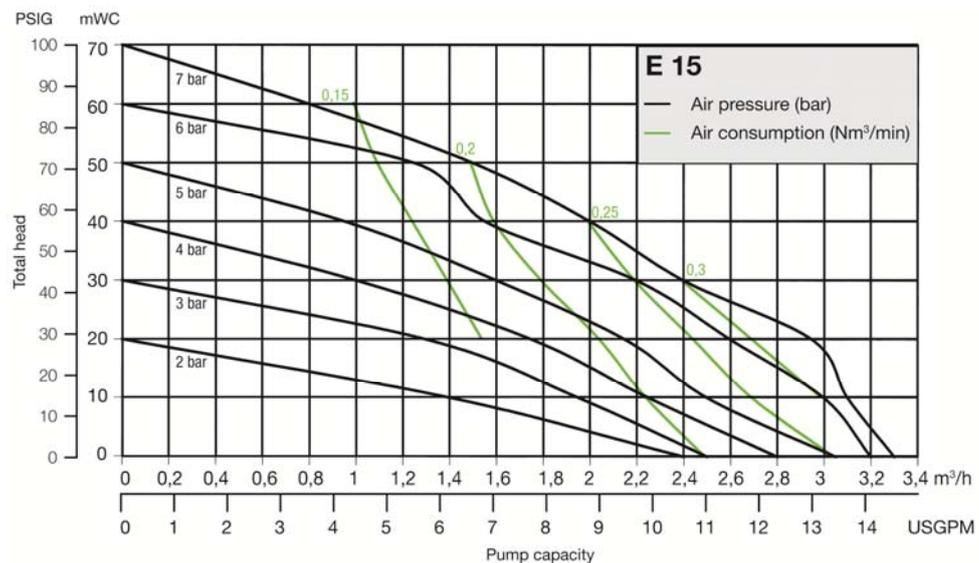
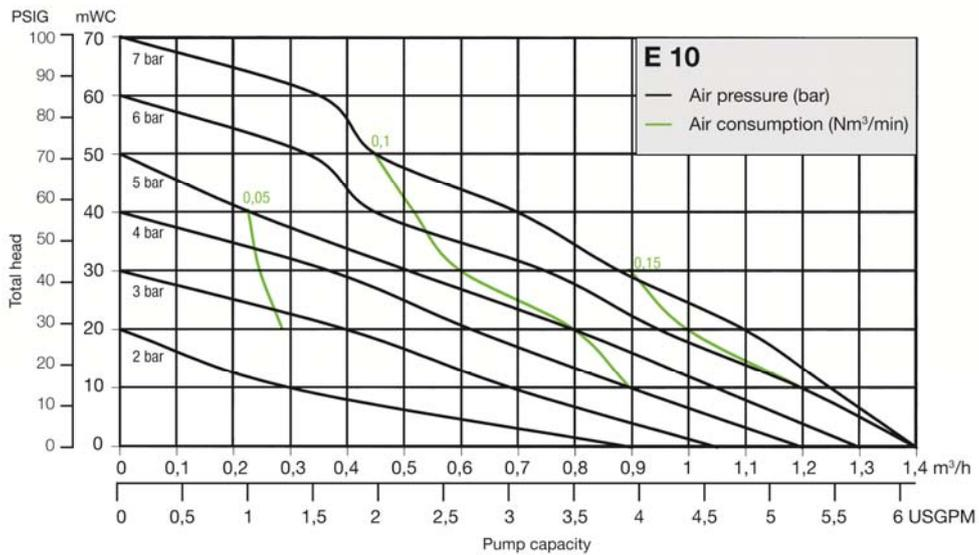
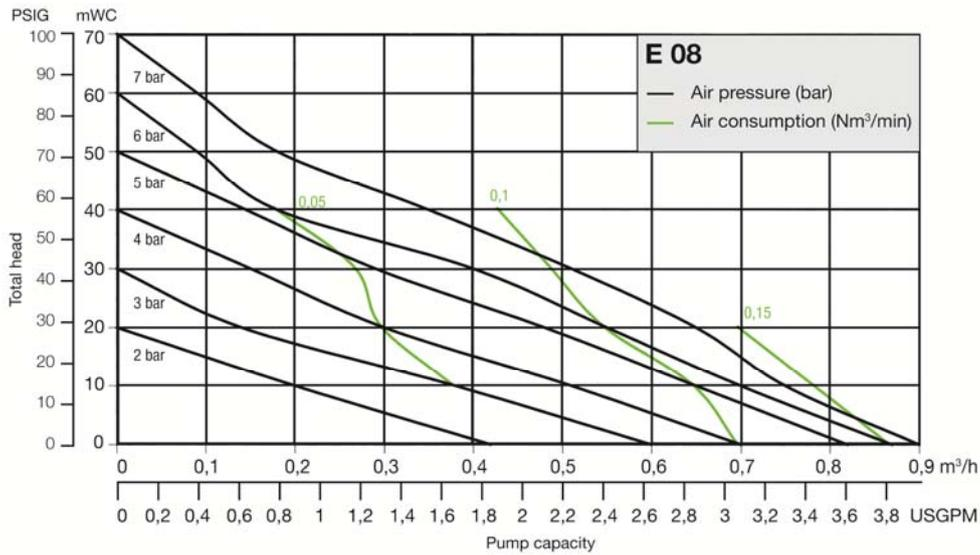

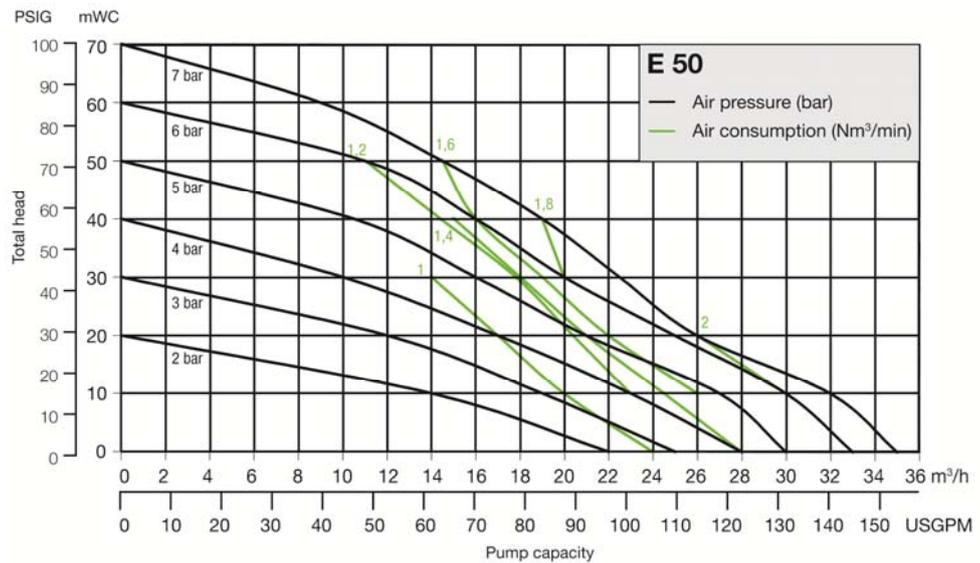
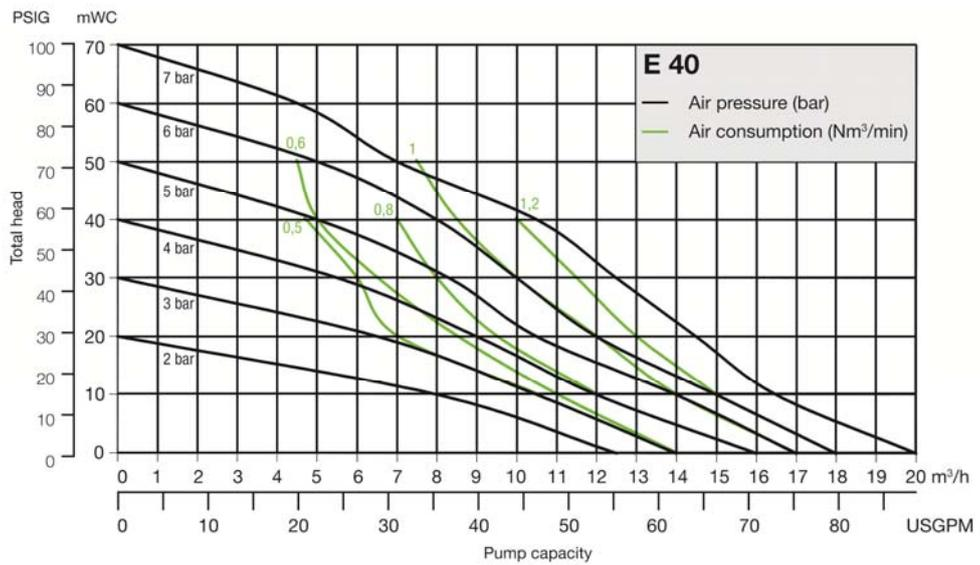
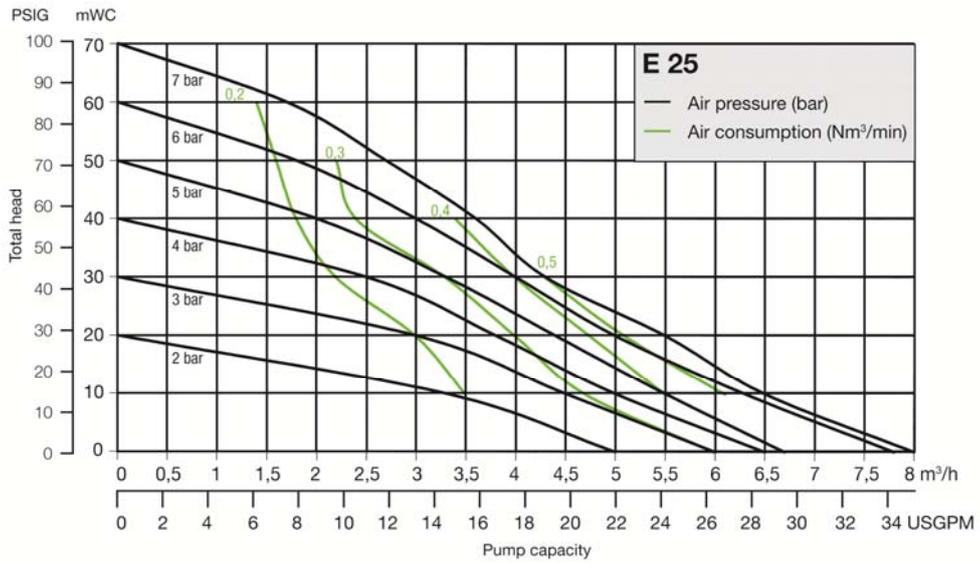

INSTALLATION

Recommended installation

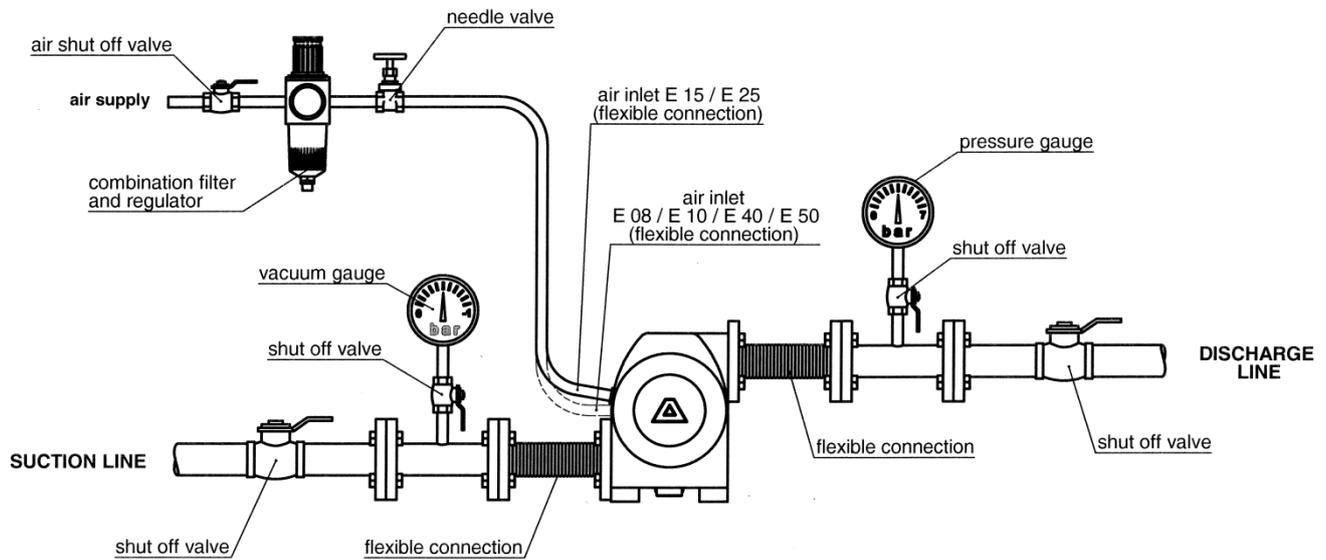

Product ports

The product ports are integrated into the center housing [4]. Different port configurations can be obtained (without using of a screwed pulsation damper only). The standard configuration of the E-Series at delivery is with the suction inlet horizontally at the bottom and the discharge outlet horizontally at the top (figure 8.1). Further possible configurations:

- Suction inlet vertically at the bottom, the discharge outlet horizontally at the top (figure 8.2)
To obtain this configuration, the plug of the center housing [13] has to be removed and set in the standard inlet.
- Suction inlet horizontally at the bottom, the discharge outlet vertically at the top (figure 8.3)
Unscrew the housing bolts [19], take off the side housings [1] and turn the center housing [4]. Remount the pump and adjust the plug [13] accordingly.

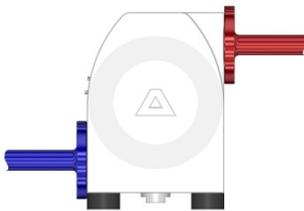

fig. 8.1

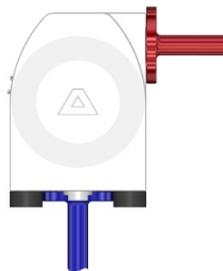

fig. 8.2

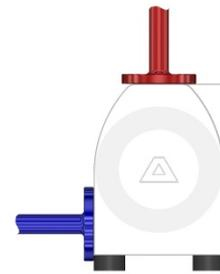

fig. 8.3

Startup operations

UV-radiation can damage the housing parts of pumps made of PE (material code E and F). In general, the pump has to be connected load free. Neglecting this causes leakage and maybe even damages. To avoid vibrations, pulsation dampers and compensators are recommended. Before connecting the pump, take the yellow blind plugs out of the suction and discharge connections as well as the air inlet [23] in the center housing [4]. The air inlet is located below the bilingual sticker with safety instructions. The connections of ALMATEC air-operated diaphragm pumps made of plastic have slightly tapered threads. Use threadseal only sparingly, otherwise the connections could be damaged.

The operator is responsible for an adequately stability and an appropriate fixation of the piping according to the state of the art. To facilitate the installation and maintenance shut off valves should be installed right before and after the pump. The nominal width of the connection pipes has to be chosen in accordance to the connections of the pump. A smaller piping can cause cavitation (suction line) as well as a loss of performance (suction and discharge line). In case the pipe is too big, the dry suction capacity of the pump can decrease. Connect the suction line to the lower connection in the center housing [4]. Seal the suction line diligently; hosepipes should be suitably armoured. A suction line continuously rising will prevent the formation of air locks in the line which would affect the suction lift.

The air inlet [23] is located in the middle of the center housing [4]. When delivered it is covered by a bilingual sticker with safety instructions, which can be easily removed. Before installation, make sure that the air supply pipe is free of solids. To supply the pump with driving air sufficiently, the pipe diameter should match the size of the air inlet. Take care that no dirt or particles can intrude into the pump during the connection, as these can accumulate inside the pump and can cause malfunctions. An air filter [24] directly behind the air inlet [23] (not included in E 08 and E 10) prevents the entry of bulk particles.

The integrated air control system *PERSWING P*[®] [26] is a precision-control that requires oil-free, dry and clean compressed air for optimal function. If humidity is expected, a water separator or air dryer has to be fitted to protect the pump from blocking by ice. The ideal condition is the dewpoint of air at -20°C (-4°F). In humid surroundings, icing from the outside may occur despite the driving air is dried. If so, a prolonged waste-air-exhaust (ca. 500 mm / 20 inch by pipe or hose) can be helpful. When installing the pump into boards or cabinets, it has to be ensured that cold air does not get caught behind the muffler. In applications with a tendency to freezing at the waste air exhaust, good experiences in practise have been achieved by pre-heating the driving air to increase the distance to the dew point of the air. Doing so, it has to be considered that the driving air temperature generally may not exceed 50°C (122°F) to avoid expansion and sticking effects on the air side. This maximum air temperature is a well valid when using a compressor producing warm air which is e.g. often true for truck compressors.

The pressure of the driving air should be limited to the amount required to meet the performance needed. Excessive pressure increases both the air consumption and the wear of the pump. The pump is regulated by tuning the flow rate of the air. For a proper operation at the lower performance range the regulation via a needle valve is recommended. An empty pump has to be driven slowly (e.g. via a needle-valve). The pump starts automatically. Pumps of the E-Series are self-priming when dry, thus it is not necessary to fill the suction line of the pump. During slow operation of the pump the dry suction lift is better than during high stroke frequency. The suction lift capacity of a liquid-filled pump, however, is much higher.

The pump is appropriate for running dry during slow operation. Dry running at high stroke frequency causes premature wear. The pumps can briefly (up to max. one hour) be operated against a closed discharge line. Throttling on the suction side may damage the pump. When the pump operation has been stopped by a closed discharge, the pressure equilibrium of the diaphragms must be ensured. This can be achieved by keeping the pump connected to the air supply pressure; for longer stoppage, the pump must be released from the pressure within the system on both fluid side and air supply side.

Torque values



Immediately before putting the pump into operation as well as after some hours of pumping, the housing bolts [19] have to be fixed according to the torque data of the following schedules, as the elements of construction "settle". The valve stops discharge valve [9] and the plugs [11/13] have to be fixed too. As a reminder the air inlet [23] is covered by a corresponding sticker at delivery condition. Fixing all these parts is necessary as well after periods of stoppage, at temperature variations, after transport and dismantling the pump. In case of temperature varying between extremes or high temperature difference between the liquid and the surrounding, the housing bolts should be controlled more frequently (interval proposals are available on request). The following schedules show the torque values of the pump housing bolts, of the damper housing bolts (when using a pulsation damper of the ET-Series) and of the optional flange connection (optional equipment codes F3/F4/F5).

Pump size	E 08	E 10	E 15	E 25	E 40	E 50
Torque values for housing bolts - Nm (ft lbs):						
PE pumps	-	-	8,5 (6.3)	14 (10.3)	18 (13.3)	23 (17)
PTFE pumps	2 (1.5)	4,5 (3.3)	6,5 (4.8)	11 (8.1)	15 (11.1)	19 (14)

Damper size	ET 10	ET 15	ET 25	ET 40	ET 50
Torque values for damper housing bolts					
Nm (ft lbs): PE damper	-	3 (2.2)	6 (4.4)	10 (7.4)	11 (8.1)
PTFE damper	2 (1.5)	3 (2.2)	6 (4.4)	10 (7.4)	11 (8.1)

Pump size	E 15	E 25	E 40	E 50
Torque values for flange connections - Nm (ft lbs):	4 (3)	5 (3.7)	12 (8.9)	15 (11.1)

Safety instructions



- Installation, operation, and maintenance by qualified staff only.
- Before start-up of the pump anyone should acquaint oneself with the explanations of the chapter troubleshooting (see pages 16/17). Only by this the defect quickly can be realized and eliminated in case of trouble. Problems which cannot be solved or with an unknown reason should be passed on to the manufacturer.
- Before any maintenance and service procedures arising on the pump or on the optional equipments, the complete installation has to be turned off and protected against accidental turn on. This is possible by a lockable emergency stop for the air supply of the pump. Additional a danger sign against restart should be attached.
- Pressure tests of the plant a pump is included in may only be carried out with the pump disconnected from the pressure on both ports or by using the pressure the pump develops while operating. The load of a pressure in the plant may damage the pump.
- AODD pumps must not be operated with a positive suction pressure.
- Depending on the conditions of operation, the liquid conveyed might escape from the pump through the muffler in case of a diaphragm rupture (in this case muffler has to be replaced). For further safety requirements the optional equipment diaphragm monitoring and barrier chamber system are recommended.
- In case of a diaphragm rupture, it might be possible for the fluid pumped to intrude into the air side of the pump. In very adverse conditions - e.g. pressure within the fluid system during stopped air supply - the fluid might as well find its way into the air supply lines. To protect other devices like pulsation dampers or even pneumatic valves, it is recommended to protect the air supply line accordingly, e.g. via a non-return valve. This would as well avoid polluting the air supply line.
- The state of the muffler has to be inspected regularly, as a blocked muffler can be forced out of the pump. If this happens, damages of properties and/or persons cannot be excluded.
- If the product tends to settle, the pump has to be flushed regularly. For larger solids a filter has to be installed in the suction line.

- In case of delivery of hot liquids the wetted pump must not standstill for a longer time, because it could lead to temporary leaks in the valve area and to a blockade of the air control system.
- The relevant effective security advises have to be respected.
- Pools of liquid which appear in the near outer area of the pump have to be inspected on danger potential, if necessary safety measures are to be taken.
- Chemical and biological reactions in the product chamber of the pump (mixture of different substances) and the freezing of the liquid have to be avoided.
- Before starting to disassemble the pump, take care that the pump has been emptied and rinsed. Both ports piping are to be closed and drained if applicable. Further the pump has to be cut off from any energy on the air and product side. If the pump is being deported from the plant, a reference about the delivered liquid has to be attached. A template is available on the Almatec website.
- Please respect the relevant additional security advices, if the pump has been used for aggressive, dangerous or toxic liquids (e.g. suitable protective equipment according to the safety data sheet of the liquid). In case of a diaphragm rupture, it is possible that residues of the liquid remain behind the diaphragms, in the area of the air control system and at the muffler, despite of several flushing processes. Hence, appropriate safety equipment according to the safety data sheet of the liquid is indispensable.
- Before putting the pump back into operation, the tightness of the pump has to be checked.
- Air-operated diaphragm pumps can lead to bruises when lifting, sinking or assembling them. Appropriate accessories and safety equipments are to be used. Big and heavy modules have to be fixed and secured to lifting gears when transporting/replacing them.
- Especially when deliver critical liquids, wear parts, like diaphragms, should be replaced within a preventive maintenance.
- The use of non-original ALMATEC spare parts and structural changes lead to the lapse of the warranty immediately. When operating such a pump, damages of properties and/or persons cannot be excluded.
- The operation of the pump with nitrogen as driving gas is possible. In closed rooms sufficient ventilation must be provided.
- Possible electrical connections (e.g. when using optional equipment with controllers) may be executed by a qualified person only. The regulations of the respective manufacturers are to be followed.
- At any work arising it has to be made sure that no explosive atmosphere can appear. Appropriate safety equipment is recommended.
- The pump is tested with water before shipment. Water residues inside the pump cannot be precluded. If the liquid, which is wanted to be conveyed, potentially interacts with water, please consult Almatec.
- Procedure for pump return: According to the requirements of our 14001-certification, every unit which is send to ALMATEC for diagnosis or maintenance reasons has to be accompanied by a filled out decontamination-sheet. Otherwise a processing is not possible. The decontamination-sheet is enclosed to this manual. Please pay attention to the further safety regulations.

Using as submersible pump

Consider the following advises when using an E-Series pump as a submersible pump: When immersing an air-operated diaphragm pump, it must generally be ensured that the waste air is deducted above the fluid level with a pipe or similar. The pump must be located vertically upright to guarantee proper function. Minute leakage on the air inlet or outlet can block the air valve. The pump must be disconnected from the pressure within the system during standstill. When choosing the pump type, it must be taken into consideration that all external parts - even those non-wetted during standard operation - like covers, shock absorbers, connections etc. must be resistant to the fluid pumped. Please consider as well that depending on the material, the pump must be weight down resp. fixed.

Additional temperature hints

The temperature and pressure limitations listed on page 5 are solely based on mechanical temperature limits of the housing material used. Depending on the fluid pumped, the maximum safe operating temperature of the housing material can be reduced significantly.

A general aspect of lower temperatures is, that below 0°C (32°F) cold-brittling of the elastomers used within the pumps can result in accelerated wear. Regarding the housing materials, please note that PE - other than PP - keeps its mechanical strengths at low temperatures and PTFE keeps mechanically stable as well for an extended temperature range. ALMATEC pumps of the E-Series can therefore be operated safely as well within low-temperature installations: However, with liquids below 0°C (32°F) accelerated wear of internal parts has to be accepted. Moreover, freezing, bogging or crystallisation of the fluid pumped must be avoided, especially within the pump. Emptying the pump via the drainage system (optional equipment code R) may be a useful tool to assist this.

Please consider, that viscosity and specific gravity of most fluids change with temperature (most often increasing at lower temperature). Depending on the application, this fact may not only result in a reduced flow rate, the pump may even be unable to prime the thicker and/or “heavier” fluid any more.

In case of varying application temperatures, the housing bolt tension has to be controlled very thoroughly, as variations like these can change the effective tension of the housing bolts via the different thermal expansion characteristics of single.

Providing spare parts

We recommend having spare part kits “S” on stock. These include the relevant spare parts for your pump.

MAINTENANCE

Required tools

The general design of the ALMATEC E-Series is simple. We recommend to take the explosion view in hand to identify the parts by item number that is mentioned in the following. Two tools are delivered along with each pump. The plastic one of these is designed for the mounting of the air-valve [26], the other one for the mounting of valve seat [16]. Further special tools are not required.

		Pump size	E 08	E 10	E 15	E 25	E 40	E 50
Item	Description	Tool	Tool size	Tool size	Tool size	Tool size	Tool size	Tool size
8	Thread bolt	Slot screwdriver **	0,8 x 5,0	0,8 x 5,0	0,8 x 5,0	1,0 x 5,5	1,6 x 8,0	1,6 x 8,0
9	Valve stop, discharge valve	Face pin spanner wrench	4 mm	5 mm	6 mm	8 mm	8 mm	10 mm
11	Plug, side housing	Face pin spanner wrench	4 mm	5 mm	6 mm	8 mm	8 mm	10 mm
13	Plug, center housing	Open-end spanner	24 mm	24 mm	30 mm	46 mm	60 mm	65 mm
16	Valve seat, ball valves/cylinder valves	ALMATEC Tool*	2 08 901 10	2 10 901 10	2 15 901 10	2 25 901 10	2 40 901 10	2 50 901 10
19	Housing bolt, cpl.	Open-end spanner/ring wrench/socket wrench	7 mm	8 mm	10 mm	13 mm	13 mm	17 mm
21	Set screw, shaft	Allen key	-	-	5 mm	6 mm	8 mm	10 mm
23	Air inlet	Open-end spanner	13 mm	13 mm	19 mm	19 mm	27 mm	27 mm
26	PERSWING P® air control system, cpl	ALMATEC Tool* + ring wrench	1 08 901 54 19 mm		1 15 901 54 24 mm			

* Attached to each pump delivery ** Examples, please check yourself



Face pin spanner wrench



Disassembly

When dismantling a pump the mentioned procedures and safety notes on the pages 9-11 have to be considered generally. Among the different sizes of the E-Series - E 15 to E 50 - only the number of housing bolts [19] varies. Besides, for the sizes E 08 and E 10 the shaft [20] additionally functions as the pilot piston for the air-valve. In these pumps E 08 and E 10, there are no shaft piston rings [22] and no set screws [21] nor an air filter [24]. Please keep these differences in construction in mind when reading the following dismantling instructions.

Take the cover [3] out of the side housings [1], to get access to the housing bolts [19]. Unscrew the housing bolts [19] on one side using two socket wrenches, remove tension disc [2] first and side housing [1] second. Work carefully to ensure that the sealing surfaces in contact to the diaphragms are not damaged. Carefully draw the housing bolts [15] out of the pump and remove the second cover [2]. The center housing [4] and both side housings [1] are removeable now. Remove the sleeve [5] out from the side housing [1]. Take the O-



fig. 14.1

rings sleeve [6] out of the center housing [4] and both side housings [1] for a possible renewal.

For further dismantling of the side housings [1], screw out the valve stop, discharge valve [9] with a face spin spanner wrench (figure 14.1). Alternatively, you can stick two housing bolts [19] into the holes in the valve stop [9] and loosen the valve stop with a third housing bolt [19] fixed in between the others. Take out the ball valve [15] resp. cylinder valve [15] and the O-ring, valve stop, discharge valve [10].



fig. 14.2



fig. 14.3

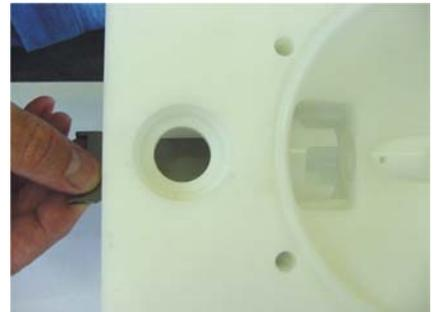

fig. 14.4

Use the metallic mounting tool to unscrew the valve seat [16] (figure 14.2/14.3). The plug, side housing [11] can be unscrewed the same way as described for the valve stop [9]. Take care of O-ring plug side housing [12]. Loosen the thread bolt [8] with a slot screwdriver. Remove lock bolt [7] and afterwards ball/cylinder valve [15]. Turn the mounting tool and screw the valve seat [16] into the side housing [1] (figure 14.4). The valve seat [16] can now be removed from inside the side housing.



fig. 14.5

Screw one diaphragm [18] left-turning off the shaft [20] and pull the other diaphragm [18] together with the shaft [20] out of the center housing [4]. Take out set screws shaft [21] of the diaphragms [18] by using an Allen key (figure 14.5). Remove both parts of the shaft piston rings [22] from their grooves carefully (figure 14.6); do not damage the edges in the center housing, a re-assembly of the same piston rings is impossible, they have to be replaced. Unscrew the muffler [25], the air inlet [23] and the air filter [24] out of the center housing [4]. To remove the *PERSWING P*® air control system [26], screw off both end caps using

the plastic mounting tool delivered with the pump (figure 14.7). Take out main and pilot piston. Push out the air valve housing with the mounting tool turned around (figure 14.8).



fig. 14.6



fig. 14.7



fig. 14.8

A video of the disassembly of an E-Series pump is available on our website.

<http://www.psgdover.com/en/psqtv/videos-by-brand/psqtv-almatec/item/5292-almatec-e-series-disassembly-english>

Assembly

The re-assembly of the components is principally carried out vice-versa to the dismantling. Here are some additional references.

For the installation of the *PERSWING P*® air control system [26], first screw in one end cap flushly into the center housing [4]. Insert one of the six O-rings air-valve housing [27] into the end cap from the inside. Moisture the four O-rings [27] of the air-valve housing with a bit of water and push the housing into the center housing [4] using the mounting tool. Take care that it slips in softly. Do never insert the housing violently with a hammer. In case the housing cocks or hardly gets in, take it out again completely and start again. Insert the main piston and the pilot piston. Lay the sixth O-ring [27] on the edge of the air valve housing and screw in the second end cap.



fig. 15.1

To assemble new piston rings [22] (pump sizes E 15 - E 50 only), carefully shape them like kidneys with snap ring pliers and insert the rings into the grooves in the center housing [4] (figure 15.1); completely press the rings into the grooves smoothly using some round tool.

Screw the set screws [21] into the diaphragms and tighten them. Fix the diaphragms [18] completely into the shaft [20] with the set screws [21]. Adjust the bores in the center housing [4] to the diaphragm on both sides (turn slightly backwards if necessary). The sealing surfaces of the diaphragms and the side housings [1] have to be absolutely clean and undamaged; mere small scratches can cause leaking (if necessary,

smoothen the housing surfaces carefully with fine sandpaper).

When assembling the housing bolts [19] pay attention to the different lengths of the threads located on both sides. Push a spring washer on the side with the shorter thread and screw on the nut to the stop.

Cautiously push the O-rings sleeve [6] into the side housings [1] and the center housing [4] (avoid bending the rings by all means! If necessary, moisture and softly twist the rings). When installing the valve stop, discharge valve [9] always start with inserting the O-ring, valve stop discharge valve [10] into the side housing [1] carefully, do NOT shove the O-ring onto the valve stop [9]. It has to be ensured that the O-ring is in direct flat contact to the horizontal surface at the end of the thread (press in with an appropriate round stick if necessary).



fig. 15.2

When building in cylinder valves, take care that these valves [15] are set into the valve seat [16] with flat side first (fig. 15.2). Afterwards insert lock bolt [7] and bolt together with the thread bolt [8]. Shove one diaphragm [18] into the center housing [4], lay the side housing [1] and the tension disc [2] onto the diaphragm and fix its position with housing bolts [19]. After that, shove the other diaphragm [18] into the center housing [4] and carefully push the housing bolts [19] completely through the center housing [4] [slightly turning the bolts

helps them to find their way]. Take care, that the diaphragms [18] are not damaged. Adjust the second side housing [1] and the tension disc [2]. Fix the housing bolts [19] crosswise evenly according to the given torque values until the side housings [1] are situated on the center housing [4]. Any further tightening of the bolts does not improve sealing but can deform the housing! Before putting the pump back into operation, the tightness of the pump has to be checked.

A video of the assembly of an E-Series pump is available on our website.

<http://www.psgdover.com/en/psqtv/videos-by-brand/psqtv-almatec/item/5293-almatec-e-series-assembly-english>

TROUBLESHOOTING

Malfunction	Possible Reason	Solutions/Remarks
pump does not operate	air supply line blocked/closed muffler blocked working chambers blocked air control system defective discharge line blocked/closed	open air supply clean/replace muffler remove blockage replace air valve system clean/open line
pump operates unsteadily	piston rings worn air control system worn diaphragm rupture air control system soiled check valve blocked icing	replace piston rings replace air control system replace diaphragm, clean pump clean/replace air control system cleaning, removal of bulk particles improve air processing
air within liquid	suction line leaky container with liquid empty diaphragm rupture cavitation	seal suction line fill/new container replace diaphragm adapt suction lift, possibly install suction pressurised air chamber
insufficient discharge pressure	insufficient pressure/amount of driving air air supply line leaky air control system leaky check valve worn more air consuming components	increase air supply check/repair air supply replace air control system check/replace check valve increase pressure/amount of air
output decreases	air control system soiled icing air pressure drop suction line/inlet strainer soiled discharge line/outlet strainer soiled muffler blocked check valve worn change in viscosity more air consuming components	clean/replace air control system improve air processing: dryer/filter ensure sufficient supply of air cleaning cleaning replace the muffler replace valve change back/adjust pump increase pressure/amount of air
pump stops itself	icing of the air control system air pressure too low air pressure drop discharge line blocked air filter blocked valve closed air control system defective wear/leaking of air control system diaphragm rupture check valve blocked/worn	improve air processing: dryer/heater etc. increase air pressure ensure sufficient air supply clean discharge line clean air filter open valve replace air control system replace air control system replace diaphragm, clean pump clean/replace check valve

Malfunction	Possible Reason	Solutions/Remarks
pumps operates, however suction capacity insufficient	<p>pump operates too fast operation beyond physical limits cavitation operation beyond pump capacity</p> <p>air cushion within suction/discharge line dry suction against discharge pressure valve filter within suction line closed valve filter within discharge line closed container with liquid empty vacuum inside the container wear of the check valves suction line leaky suction line blocked air pressure cushion at discharge check valve blocked</p>	<p>start more slowly adjust installation check, cool down adjust installation resp. install bigger pump bleed the line wet pump, start without pressure open valve/clean filter open valve/clean filter fill/new container bleed container replace valves seal suction line clean suction line bleed discharge line clean/replace valve</p>
insufficient suction capacity after pump repair	<p>connections tighten incompletely check valves inserted falsely</p>	<p>tighten/seal connections correct positioning of check valves</p>
diaphragm overstrained	<p>pressure within the plant/system</p> <p>inadmissible vacuum icing</p>	<p>ensure that pressure is only developed by the pump itself, check plant/valves, replace diaphragms check suction line, open valve improve air processing</p>
leaking between housing parts	<p>housing bolts loosened O-rings sleeve damaged diaphragms attacked chemically diaphragms overstrained tension installation/pipework</p>	<p>tighten bolts, check pump replace O-rings replace diaphragms replace diaphragms loosen, eliminate tension, use of a compensator</p>
muffler grey	driving air too humid, icing	improve quality of driving air
muffler black	soiled, oily air	improve quality of driving air, install sensitive filter in suction line
pump is connected to air but does not operate	<p>air control system blocked bulk particles/dirt</p> <p>chemical influence (O-rings swollen) valve closed in discharge line</p>	<p>clean/replace air control system clean pump, replace necessary parts, improve air quality check, replace damaged parts open valve</p>
liquid leaves the pump via the muffler	diaphragm rupture	replace diaphragms, clean pump

SPARE PART LISTS
Pump code EEE – ETZ, material housing parts: Polyethylene (PE)

Size				E 15 E..	E 25 E..	E 40 E..	E 50 E..
Item	Pc.	Description	Material	Part-No.	Part-No.	Part-No.	Part-No.
1	2	Side housing	PE	7 15 010 51	7 25 010 51	7 40 010 51	7 50 010 51
2	2	<i>Tension disc</i>	1.4301	7 15 008 22	7 25 008 22	7 40 008 22	7 50 008 22
3	2	<i>Cover</i>	PE	7 15 009 51	7 25 009 51	7 40 009 51	7 50 009 51
4	1	Center housing	PE	7 15 011 51	7 25 011 51	7 40 011 51	7 50 011 51
5	4	Sleeve	PE	2 15 012 51	2 25 012 51	2 40 012 51	2 50 012 51
6	8	O-ring, sleeve, code EE.	EPDM	9 20 631 72	9 33 632 72	9 50 633 72	9 62 634 72
		O-ring, sleeve, code EN.	NBR	9 20 631 71	9 33 632 71	9 50 633 71	-
		O-ring, sleeve, code ET.	FEP/FKM	9 20 631 59	9 33 632 59	9 50 633 59	9 62 634 59
7	2	Lock bolt	PE	7 15 013 52	7 25 013 52	7 40 013 52	7 50 013 52
8	4	Thread bolt	PE	2 08 014 52	2 10 014 52	2 15 014 52	2 15 014 52
9	2	Valve stop, discharge valve	PE	7 15 015 51	7 25 015 51	7 40 015 51	7 50 015 51
10	2	O-ring, valve stop discharge valve, code EE.	EPDM	9 24 625 72	9 38 626 72	9 57 627 72	9 76 628 72
		O-ring, valve stop discharge valve, code EN.	NBR	9 24 625 71	9 38 626 71	9 57 627 71	-
		O-ring, valve stop discharge valve, code ET.	FEP/FKM	9 24 625 59	9 38 626 59	9 57 627 59	9 76 628 59
11	2	Plug, side housing	PE	7 15 017 51	7 25 017 51	7 40 017 51	7 50 017 51
12	2	O-ring, plug side housing, code EE.	EPDM	9 25 610 72	9 40 613 72	9 62 634 72	9 79 353 72
		O-ring, plug side housing, code EN.	NBR	9 25 610 71	9 40 613 71	9 62 634 71	-
		O-ring, plug side housing, code ET.	FEP/FKM	9 25 610 59	9 40 613 59	9 62 634 59	9 79 353 59
13	1	Plug, center housing	PE	7 15 019 51	7 25 019 51	7 40 019 51	7 50 019 51
14	1	O-ring, plug center housing, code EE.	EPDM	9 33 632 72	9 50 633 72	9 62 634 72	9 73 635 72
		O-ring, plug center housing, code EN.	NBR	9 33 632 71	9 50 633 71	9 62 634 71	-
		O-ring, plug center housing, code ET.	FEP/FKM	9 33 632 59	9 50 633 59	9 62 634 59	9 73 635 59
15	4	Cylinder valve, code E.Z	PTFE	7 15 016 60	7 25 016 60	7 40 016 60	7 50 016 60
		Ball valve, code E.E	EPDM	1 15 032 72	1 25 032 72	1 40 032 72	1 50 032 72
		Ball valve, code E.N	NBR	1 15 032 71	1 25 032 71	1 40 032 71	-
		Ball valve, code E.S	SS	1 15 032 22	1 25 032 22	-	-
		Ball valve, code E.T	PTFE	1 15 032 60	1 25 032 60	1 40 032 60	1 50 032 60
16	4	Valve seat, ball valves	PE	2 15 018 52	2 25 018 52	2 40 018 52	2 50 018 52
		Valve seat, cylinder valves	PE	7 15 018 52	7 25 018 52	7 40 018 52	7 50 018 52
17	4	<i>Shock absorbers</i>	NR	1 15 322 85	1 15 322 85	1 40 322 85	1 40 322 85
18	2	Diaphragm, code EE.	EPDM	1 15 031 72	1 25 031 72	1 40 031 72	1 50 031 72
18	2	Diaphragm, code EN.	NBR	1 15 031 70	1 25 031 70	1 40 031 70	-
		Diaphragm, code ET.	PTFE	1 15 031 67	1 25 031 67	1 40 031 67	1 50 031 67
19	*	<i>Housing bolt, cpl.</i>	1.4305	7 15 020 22	7 25 020 22	7 40 020 22	7 50 020 22
20	1	<i>Shaft</i>	1.4301	2 15 030 22	2 25 030 22	2 40 030 22	2 50 030 22
21	2	<i>Set screw, shaft</i>	1.4305	9 10 220 22	9 12 221 22	9 16 222 22	9 20 223 22
22	2	<i>Shaft piston ring, cpl.</i>	PTFE	1 15 041 64	1 25 041 64	1 40 041 64	1 50 041 64
23	1	<i>Air inlet</i>	PETP	1 15 047 84	1 15 047 84	1 40 047 84	1 40 047 84
24	1	<i>Air filter</i>	PE	1 15 043 51	1 15 043 51	1 40 043 51	1 40 043 51
25	1	<i>Muffler, cpl.</i>	PE	1 15 244 51	1 15 244 51	1 40 244 51	1 50 244 51
26	1	<i>PERSWING P® air control system, cpl.</i>	PETP	2 15 001 84	2 15 001 84	2 40 001 84	2 50 201 84
27**	6	<i>O-ring, air valve housing</i>	NBR	9 35 504 71	9 35 504 71	9 46 515 71	9 66 533 71

* E 15 and E 25: 6 pieces; E 40 and E 50: 8 pieces ** included in item 26

All parts in italics are not product wetted.

Please see page 4 for explanation of the pump code.

When ordering please state the serial number of the pump.

For spare part lists for special equipment please see page 24 and the following ones.

Pump code TEE – TTZ, material housing parts: PTFE

Size				E 08 T..	E 10 T..	E 15 T..	E 25 T..	E 40 T..	E 50 T..
Item	Pc.	Description	Material	Part-No.	Part-No.	Part-No.	Part-No.	Part-No.	Part-No.
1	2	Side housing	PTFE	7 08 010 60	7 10 010 60	7 15 010 60	7 25 010 60	7 40 010 60	7 50 010 60
2	2	<i>Tension disc</i>	1.4301	7 08 008 22	7 10 008 22	7 15 008 22	7 25 008 22	7 40 008 22	7 50 008 22
3	2	<i>Cover</i>	PE	7 08 009 51	7 10 009 51	7 15 009 51	7 25 009 51	7 40 009 51	7 50 009 51
4	1	Center housing	PTFE	7 08 011 60	7 10 011 60	7 15 011 60	7 25 011 60	7 40 011 60	7 50 011 60
5	4	Sleeve	PTFE	2 08 012 69	2 10 012 69	2 15 012 69	2 25 012 69	2 40 012 69	2 50 012 69
6	8	O-ring, sleeve, code TE.	EPDM	-	9 15 630 72	9 20 631 72	9 33 632 72	9 50 633 72	9 62 634 72
		O-ring, sleeve, code TN.	NBR	-	-	9 20 631 71	9 33 632 71	9 50 633 71	-
		O-ring, sleeve, code TT.	FEP/FKM	9 12 629 59	9 15 630 59	9 20 631 59	9 33 632 59	9 50 633 59	9 62 634 59
7	2	Lock bolt	PTFE	7 08 013 60	7 10 013 60	7 15 013 60	7 25 013 60	7 40 013 60	7 50 013 60
8	4	Thread bolt	PTFE	7 08 014 60	7 08 014 60	2 08 014 60	2 10 014 60	2 15 014 60	2 15 014 60
9	2	Valve stop, discharge valve	PTFE	7 08 015 60	7 10 015 60	7 15 015 60	7 25 015 60	7 40 015 60	7 50 015 60
10	2	O-ring, valve stop discharge valve:	EPDM NBR FEP/FKM	-	9 19 624 72	9 24 625 72	9 38 626 72	9 57 627 72	9 76 628 72
		- code TE.		-	-	9 24 625 71	9 38 626 71	9 57 627 71	-
		- code TN.		9 16 623 59	9 19 624 59	9 24 625 59	9 38 626 59	9 57 627 59	9 76 628 59
- code TT.									
11	2	Plug, side housing	PTFE	7 08 017 60	7 10 017 60	7 15 017 60	7 25 017 60	7 40 017 60	7 50 017 60
12	2	O-ring, plug side housing, code TE.	EPDM	-	9 20 602 72	9 25 610 72	9 40 613 72	9 62 634 72	9 79 353 72
		O-ring, plug side housing, code TN.	NBR	-	-	9 25 610 71	9 40 613 71	9 62 634 71	-
		O-ring, plug side housing, code TT.	FEP/FKM	9 14 178 59	9 20 602 59	9 25 610 59	9 40 613 59	9 62 634 59	9 79 353 59
13	1	Plug, center housing	PTFE	7 08 019 60	7 10 019 60	7 15 019 60	7 25 019 60	7 40 019 60	7 50 019 60
14	1	O-ring, plug center housing:	EPDM NBR FEP/FKM	-	9 20 631 72	9 33 632 72	9 50 633 72	9 62 634 72	9 73 635 72
		- code TE.		-	-	9 33 632 71	9 50 633 71	9 62 634 71	-
		- code TN.		9 20 631 59	9 20 631 59	9 33 632 59	9 50 633 59	9 62 634 59	9 73 635 59
- code TT.									
15	4	Cylinder valve, code T.Z	PTFE	7 08 016 60	7 10 016 60	7 15 016 60	7 25 016 60	7 40 016 60	7 50 016 60
		Ball valve, code T.E	EPDM	1 10 032 72	4 15 032 72	1 15 032 72	1 25 032 72	1 40 032 72	1 50 032 72
		Ball valve, code T.N	NBR	-	-	1 15 032 71	1 25 032 71	1 40 032 71	-
		Ball valve, code T.S	SS	1 10 032 22	4 15 032 22	1 15 032 22	-	-	-
		Ball valve, code T.T	PTFE	1 10 032 60	4 15 032 60	1 15 032 60	1 25 032 60	1 40 032 60	1 50 032 60
16	4	Valve seat, ball valves	PTFE	2 08 018 60	2 10 018 60	2 15 018 60	2 25 018 60	2 40 018 60	2 50 018 60
		Valve seat, cylinder valves	PTFE	7 08 018 60	7 10 018 60	7 15 018 60	7 25 018 60	7 40 018 60	7 50 018 60
17	4	<i>Shock absorbers</i>	NR	1 08 322 85	1 08 322 85	1 15 322 85	1 15 322 85	1 40 322 85	1 40 322 85
18	2	Diaphragm, code TE.	EPDM	-	1 10 031 72	1 15 031 72	1 25 031 72	1 40 031 72	1 50 031 72
		Diaphragm, code TN.	NBR	-	-	1 15 031 70	1 25 031 70	1 40 031 70	-
		Diaphragm, code TT.	PTFE	1 08 031 67	1 10 031 67	1 15 031 67	1 25 031 67	1 40 031 67	1 50 031 67
19	*	<i>Housing bolt, cpl.</i>	1.4305	7 08 020 22	7 10 020 22	7 15 020 22	7 25 020 22	7 40 020 22	7 50 020 22
20	1	<i>Shaft</i>	1.4301	2 08 030 22**	2 08 030 22**	2 15 030 22	2 25 030 22	2 40 030 22	2 50 030 22
21	2	<i>Set screw, shaft</i>	1.4305	-	-	9 10 220 22	9 12 221 22	9 16 222 22	9 20 223 22
22	2	<i>Shaft piston ring, cpl.</i>	PTFE	-	-	1 15 041 64	1 25 041 64	1 40 041 64	1 50 041 64
23	1	<i>Air inlet</i>	PETP	1 08 047 84	1 08 047 84	1 15 047 84	1 15 047 84	1 40 047 84	1 40 047 84
24	1	<i>Air filter</i>	PE	-	-	1 15 043 51	1 15 043 51	1 40 043 51	1 40 043 51
25	1	<i>Muffler, cpl.</i>	PE	1 08 244 51	1 08 244 51	1 15 244 51	1 15 244 51	1 40 244 51	1 50 244 51
26	1	<i>PERSWING P® air control system, cpl.</i>	PETP	2 08 001 84	2 08 001 84	2 15 001 84	2 15 001 84	2 40 001 84	2 50 201 84
27**	6	<i>O-ring, air valve housing</i>	NBR	9 26 519 71	9 26 519 71	9 35 504 71	9 35 504 71	9 46 515 71	9 66 533 71

* E 08 and E 10: 4 pieces; E 15 and E 25: 6 pieces; E 40 and E 50: 8 pieces ** included in item 26

All parts in italics are not product wetted.

Please see page 4 for explanation of the pump code.

When ordering please state the serial number of the pump.

For spare part lists for special equipment please see page 24 and the following ones.

Pump code FEE – FTZ, material housing parts: PE conductive

Size				E 15 F..	E 25 F..	E 40 F..	E 50 F..
Item	Pc.	Description	Material	Part-No.	Part-No.	Part-No.	Part-No.
1	2	Side housing	PE conductive	7 15 010 55	7 25 010 55	7 40 010 55	7 50 010 55
2	2	<i>Tension disc</i>	<i>1.4301</i>	<i>7 15 008 22</i>	<i>7 25 008 22</i>	<i>7 40 008 22</i>	<i>7 50 008 22</i>
3	2	<i>Cover</i>	<i>PE conductive</i>	<i>7 15 009 55</i>	<i>7 25 009 55</i>	<i>7 40 009 55</i>	<i>7 50 009 55</i>
4	1	Center housing	PE conductive	7 15 011 55	7 25 011 55	7 40 011 55	7 50 011 55
5	4	Sleeve	PE conductive	2 15 012 55	2 25 012 55	2 40 012 55	2 50 012 55
6	8	O-ring, sleeve, code FE.	EPDM	9 20 631 72	9 33 632 72	9 50 633 72	9 62 634 72
		O-ring, sleeve, code FN.	NBR	9 20 631 71	9 33 632 71	9 50 633 71	-
		O-ring, sleeve, code FT.	FEP/FKM	9 20 631 59	9 33 632 59	9 50 633 59	9 62 634 59
7	2	Lock bolt	PE conductive	7 15 013 56	7 25 013 56	7 40 013 56	7 50 013 56
8	4	Thread bolt	PE	2 08 014 52	2 10 014 52	2 15 014 52	2 15 014 52
9	2	Valve stop, discharge valve	PE conductive	7 15 015 56	7 25 015 56	7 40 015 56	7 50 015 56
10	2	O-ring, valve stop discharge valve, code FE.	EPDM	9 24 625 72	9 38 626 72	9 57 627 72	9 76 628 72
		O-ring, valve stop discharge valve, code FN.	NBR	9 24 625 71	9 38 626 71	9 57 627 71	-
		O-ring, valve stop discharge valve, code FT.	FEP/FKM	9 24 625 59	9 38 626 59	9 57 627 59	9 76 628 59
11	2	Plug, side housing	PE conductive	7 15 017 55	7 25 017 55	7 40 017 55	7 50 017 55
12	2	O-ring, plug side housing, code FE.	EPDM	9 25 610 72	9 40 613 72	9 62 634 72	9 79 353 72
		O-ring, plug side housing, code FN.	NBR	9 25 610 71	9 40 613 71	9 62 634 71	-
		O-ring, plug side housing, code FT.	FEP/FKM	9 25 610 59	9 40 613 59	9 62 634 59	9 79 353 59
13	1	Plug, center housing	PE conductive	7 15 019 56	7 25 019 56	7 40 019 56	7 50 019 56
14	1	O-ring, plug center housing, code FE.	EPDM	9 33 632 72	9 50 633 72	9 62 634 72	9 73 635 72
		O-ring, plug center housing, code FN.	NBR	9 33 632 71	9 50 633 71	9 62 634 71	-
		O-ring, plug center housing, code FT.	FEP/FKM	9 33 632 59	9 50 633 59	9 62 634 59	9 73 635 59
15	4	Cylinder valve, code F.Z	PTFE	7 15 016 60	7 25 016 60	7 40 016 60	7 50 016 60
		Ball valve, code F.E	EPDM	1 15 032 72	1 25 032 72	1 40 032 72	1 50 032 72
		Ball valve, code F.N	NBR	1 15 032 71	1 25 032 71	1 40 032 71	-
		Ball valve, code F.S	SS	1 15 032 22	1 25 032 22	-	-
		Ball valve, code F.T	PTFE	1 15 032 60	1 25 032 60	1 40 032 60	1 50 032 60
16	4	Valve seat, ball valves	PE conductive	2 15 018 56	2 25 018 56	2 40 018 56	2 50 018 56
		Valve seat, cylinder valves	PE conductive	7 15 018 56	7 25 018 56	7 40 018 56	7 50 018 56
17	4	<i>Shock absorbers</i>	<i>NR</i>	<i>1 15 322 85</i>	<i>1 15 322 85</i>	<i>1 40 322 85</i>	<i>1 40 322 85</i>
18	2	Diaphragm, code FE.	EPDM	1 15 031 72	1 25 031 72	1 40 031 72	1 50 031 72
		Diaphragm, code FN.	NBR	1 15 031 70	1 25 031 70	1 40 031 70	-
		Diaphragm, code FT.	PTFE	1 15 031 67	1 25 031 67	1 40 031 67	1 50 031 67
19	*	<i>Housing bolt, cpl.</i>	<i>1.4305</i>	<i>7 15 020 22</i>	<i>7 25 020 22</i>	<i>7 40 020 22</i>	<i>7 50 020 22</i>
20	1	<i>Shaft</i>	<i>1.4301</i>	<i>2 15 030 22</i>	<i>2 25 030 22</i>	<i>2 40 030 22</i>	<i>2 50 030 22</i>
21	2	<i>Set screw, shaft</i>	<i>1.4305</i>	<i>9 10 220 22</i>	<i>9 12 221 22</i>	<i>9 16 222 22</i>	<i>9 20 223 22</i>
22	2	<i>Shaft piston ring, cpl.</i>	<i>PTFE</i>	<i>1 15 041 64</i>	<i>1 25 041 64</i>	<i>1 40 041 64</i>	<i>1 50 041 64</i>
23	1	<i>Air inlet</i>	<i>PETP</i>	<i>1 15 047 84</i>	<i>1 15 047 84</i>	<i>1 40 047 84</i>	<i>1 40 047 84</i>
24	1	<i>Air filter</i>	<i>PE</i>	<i>1 15 043 51</i>	<i>1 15 043 51</i>	<i>1 40 043 51</i>	<i>1 40 043 51</i>
25	1	<i>Muffler, cpl.</i>	<i>Bz</i>	<i>1 15 244 34</i>	<i>1 15 244 34</i>	<i>1 40 244 34</i>	<i>1 40 244 34</i>
26	1	<i>PERSWING P® air control system, cpl.</i>	<i>PETP</i>	<i>2 15 001 84</i>	<i>2 15 001 84</i>	<i>2 40 001 84</i>	<i>2 50 201 84</i>
27**	6	<i>O-ring, air valve housing</i>	<i>NBR</i>	<i>9 35 504 71</i>	<i>9 35 504 71</i>	<i>9 46 515 71</i>	<i>9 66 533 71</i>

* E 15 and E 25: 6 pieces; E 40 and E 50: 8 pieces ** included in item 26

All parts in italics are not product wetted.

Please see page 4 for explanation of the pump code.

When ordering please state the serial number of the pump.

For spare part lists for special equipment please see page 24 and the following ones.

Pump code UEE – UTZ, material housing parts: PTFE conductive

Size				E 08 U..	E 10 U..	E 15 U..	E 25 U..	E 40 U..	E 50 U..
Item	Pc.	Description	Material	Part-No.	Part-No.	Part-No.	Part-No.	Part-No.	Part-No.
1	2	Side housing	PTFE cond.	7 08 010 65	7 10 010 65	7 15 010 65	7 25 010 65	7 40 010 65	7 50 010 65
2	2	Tension disc	1.4301	7 08 008 22	7 10 008 22	7 15 008 22	7 25 008 22	7 40 008 22	7 50 008 22
3	2	Cover	PE conductive	7 08 009 55	7 10 009 55	7 15 009 55	7 25 009 55	7 40 009 55	7 50 009 55
4	1	Center housing	PTFE cond.	7 08 011 65	7 10 011 65	7 15 011 65	7 25 011 65	7 40 011 65	7 50 011 65
5	4	Sleeve	PTFE cond.	2 08 012 68	2 10 012 68	2 15 012 68	2 25 012 68	2 40 012 68	2 50 012 68
6	8	O-ring, sleeve, code UE.	EPDM	-	9 15 630 72	9 20 631 72	9 33 632 72	9 50 633 72	9 62 634 72
		O-ring, sleeve, code UN.	NBR	-	-	9 20 631 71	9 33 632 71	9 50 633 71	-
		O-ring, sleeve, code UT.	FEP/FKM	9 12 629 59	9 15 630 59	9 20 631 59	9 33 632 59	9 50 633 59	9 62 634 59
7	2	Lock bolt	PTFE cond.	7 08 013 65	7 10 013 65	7 15 013 65	7 25 013 65	7 40 013 65	7 50 013 65
8	4	Thread bolt	PTFE cond.	7 08 014 65	7 08 014 65	2 08 014 65	2 10 014 65	2 15 014 65	2 15 014 65
9	2	Valve stop, discharge valve	PTFE cond.	7 08 015 65	7 10 015 65	7 15 015 65	7 25 015 65	7 40 015 65	7 50 015 65
10	2	O-ring, valve stop discharge valve:							
		- code UE.	EPDM	-	9 19 624 72	9 24 625 72	9 38 626 72	9 57 627 72	9 76 628 72
		- code UN.	NBR	-	-	9 24 625 71	9 38 626 71	9 57 627 71	-
		- code UT.	FEP/FKM	9 16 623 59	9 19 624 59	9 24 625 59	9 38 626 59	9 57 627 59	9 76 628 59
11	2	Plug, side housing	PTFE cond.	7 08 017 65	7 10 017 65	7 15 017 65	7 25 017 65	7 40 017 65	7 50 017 65
12	2	O-ring, plug side housing:							
		- code UE.	EPDM	-	9 20 602 72	9 25 610 72	9 40 613 72	9 62 634 72	9 79 353 72
		- code UN.	NBR	-	-	9 25 610 71	9 40 613 71	9 62 634 71	-
		- code UT.	FEP/FKM	9 14 178 59	9 20 602 59	9 25 610 59	9 40 613 59	9 62 634 59	9 79 353 59
13	1	Plug, center housing	PTFE cond.	7 08 019 65	7 10 019 65	7 15 019 65	7 25 019 65	7 40 019 65	7 50 019 65
14	1	O-ring, plug center housing:							
		- code UE.	EPDM	-	9 20 631 72	9 33 632 72	9 50 633 72	9 62 634 72	9 73 635 72
		- code UN.	NBR	-	-	9 33 632 71	9 50 633 71	9 62 634 71	-
		- code UT.	FEP/FKM	9 20 631 59	9 20 631 59	9 33 632 59	9 50 633 59	9 62 634 59	9 73 635 59
15	4	Cylinder valve, code U.Z	PTFE	7 08 016 60	7 10 016 60	7 15 016 60	7 25 016 60	7 40 016 60	7 50 016 60
		Ball valve, code U.E	EPDM	1 10 032 72	4 15 032 72	1 15 032 72	1 25 032 72	1 40 032 72	1 50 032 72
		Ball valve, code U.N	NBR	-	-	1 15 032 71	1 25 032 71	1 40 032 71	-
		Ball valve, code U.S	SS	1 10 032 22	4 15 032 22	1 15 032 22	-	-	-
		Ball valve, code U.T	PTFE	1 10 032 60	4 15 032 60	1 15 032 60	1 25 032 60	1 40 032 60	1 50 032 60
16	4	Valve seat, ball valves	PTFE cond.	2 08 018 65	2 10 018 65	2 15 018 65	2 25 018 65	2 40 018 65	2 50 018 65
		Valve seat, cylinder valves	PTFE cond.	7 08 018 65	7 10 018 65	7 15 018 65	7 25 018 65	7 40 018 65	7 50 018 65
17	4	Shock absorbers	NR	1 08 322 85	1 08 322 85	1 15 322 85	1 15 322 85	1 40 322 85	1 40 322 85
18	2	Diaphragm, code UE.	EPDM	-	1 10 031 72	1 15 031 72	1 25 031 72	1 40 031 72	1 50 031 72
		Diaphragm, code UN.	NBR	-	-	1 15 031 70	1 25 031 70	1 40 031 70	-
		Diaphragm, code UT.	PTFE	1 08 031 67	1 10 031 67	1 15 031 67	1 25 031 67	1 40 031 67	1 50 031 67
19	*	Housing bolt, cpl.	1.4305	7 08 020 22	7 10 020 22	7 15 020 22	7 25 020 22	7 40 020 22	7 50 020 22
20	1	Shaft	1.4301	2 08 030 22**	2 08 030 22**	2 15 030 22	2 25 030 22	2 40 030 22	2 50 030 22
21	2	Set screw, shaft	1.4305	-	-	9 10 220 22	9 12 221 22	9 16 222 22	9 20 223 22
22	2	Shaft piston ring, cpl.	PTFE	-	-	1 15 041 64	1 25 041 64	1 40 041 64	1 50 041 64
23	1	Air inlet	PETP	1 08 047 84	1 08 047 84	1 15 047 84	1 15 047 84	1 40 047 84	1 40 047 84
24	1	Air filter	PE	-	-	1 15 043 51	1 15 043 51	1 40 043 51	1 40 043 51
25	1	Muffler, cpl.	PE/Bz	1 08 244 51	1 08 244 51	1 15 244 34	1 15 244 34	1 40 244 34	1 40 244 34
26	1	PERSWING P® air control system, cpl.	PETP	2 08 001 84	2 08 001 84	2 15 001 84	2 15 001 84	2 40 001 84	2 50 201 84
27**	6	O-ring, air valve housing	NBR	9 26 519 71	9 26 519 71	9 35 504 71	9 35 504 71	9 46 515 71	9 66 533 71

* E 08 and E 10: 4 pieces; E 15 and E 25: 6 pieces; E 40 and E 50: 8 pieces ** included in item 26

All parts in italics are not product wetted.

Please see page 4 for explanation of the pump code.

When ordering please state the serial number of the pump.

For spare part lists for special equipment please see page 24 and the following ones.

EXPLODED VIEWS

Pump sizes E 08 / E 10

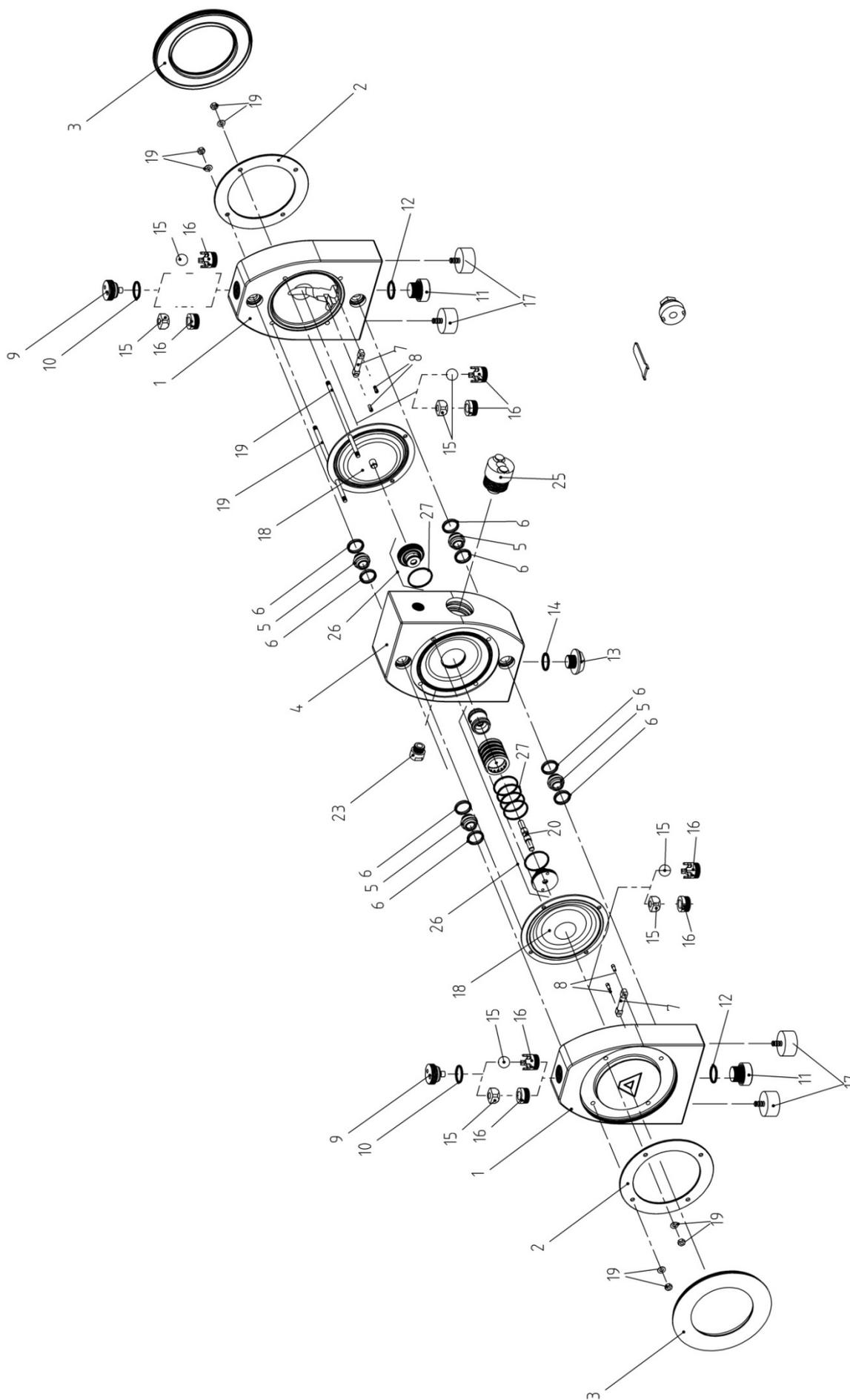

Exploded view pump sizes E 15 / E 25 / E 40 / E 50

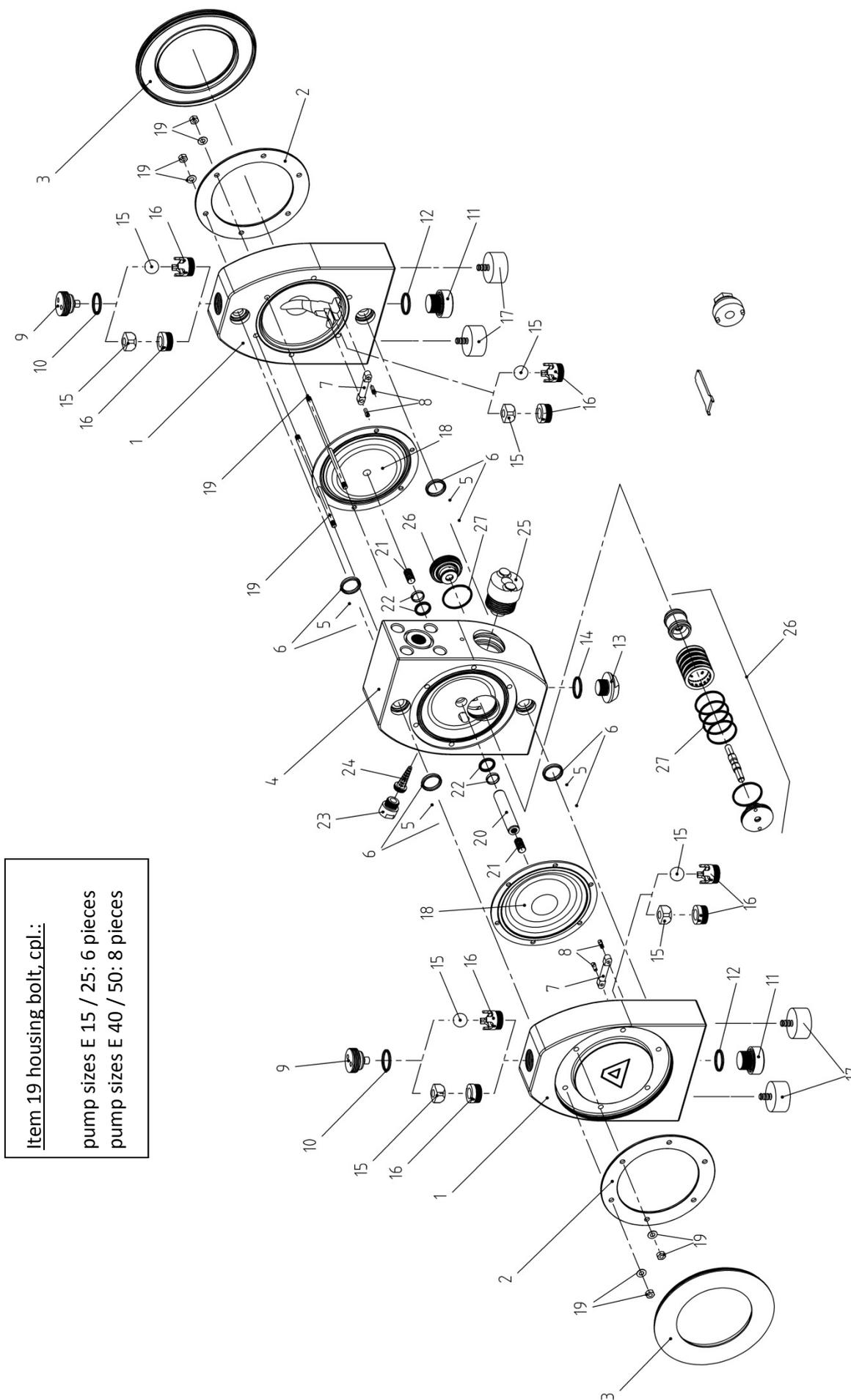

OPTIONAL EQUIPMENT

For special requirements ALMATEC air-operated double diaphragm pumps of the E-Series can be furnished with several optional equipment. The pump code informs which of these are included in the pump. The code is noted on the identification plate on the pump. For the barrier chamber system (option code BS) a separate manual is available. In the spare part lists all not product wetted parts are in italics.

Stroke counting (option code C 2, C 3, C 4, C 9, C 10)

Code C 2 / C 3 / C 4 – Capacitive stroke counting



A sensor [50] is installed in the center pump housing [4] to count the strokes. The diaphragm movement is scanned without contact by this sensor: a safe form of monitoring totally independent of external influences and the pump's mode of operation. The issued sensor pulses can be output to existing detectors or to a stroke counter (can also be supplied). When the preset value is reached, the stroke counter outputs a signal which can then be processed further, for instance in order to shut down the pump via a solenoid valve.

The stroke counting system is available in three variations:

- C 2 Stroke sensor (Namur), also for explosion-proof zone
- C 3 Stroke counting system complete with sensor and stroke counter
- C 4 Stroke counting system complete with sensor, stroke counter and controller for explosion-proof zone

In case only the sensor is included (code C 2), it has to be connected to an existing controller with Namur inlet. For applications an explosion-proof device is required for (code C 4) the intrinsically safe controller has to be installed between the sensor and the counter. The wiring diagram and technical data can be found on the electric units themselves. For further details, please refer to the data delivered by the manufacturers of the components. The controllers have to be installed in a suitable cabinet.

Code C 9 / C 10 – Pneumatic stroke counting

Differently from the optional equipment codes C 2 - C 4, the strokes of the pump are registered pneumatically on the codes C 9 / C 10. The pressure switch registers the changes in pressure within the air chamber behind one of the diaphragms and it converts the pneumatic impulse into an electrical signal.

The pneumatic stroke counting system is available in two types:

- C 9 consist of:
 - pressure switch, cpl. mounted, 1 – 10 bar
 - socket with cable 5 m
 - adaptor elbow NPT ¼ (or adaptor straight for pump sizes E 08 / E 10)
 - hose DN 4/6, 2,5 m
- C 10 consist of:
 - as C 9 and a stroke counter
- A pump with code "C 8" is prepared for pneumatic stroke counting. That means it already has the hole for the hose connection, but it is closed by a plug for a later use.

For assembly screw the adaptor elbow (or adaptor straight for pump sizes E 08 / E 10) into the additional air connection of the pump (it is possible that the adaptor is already installed). The position of the air inlet varies depending on the pump type and the pump size (see comments below). Link up the adaptor and the pressure switch with the hose. Connect the socket to the electrical connection plug of the pressure switch and the cable to existing registering devices (code C 9) resp. to the enclosed stroke counter (code C 10). Technical data, connection schemes and further details can be found in the technical documentation delivered by the manufacturers of the pressure switch and the stroke counter.



The pneumatic stroke counting system requires a minimum air pressure of 1.5 bar for optimal function!

The air inlet for the pneumatic stroke counting system must not be confused with the actual air inlet of the pump. Therefore, you will find some advises adapted to the pump type and the pump size.

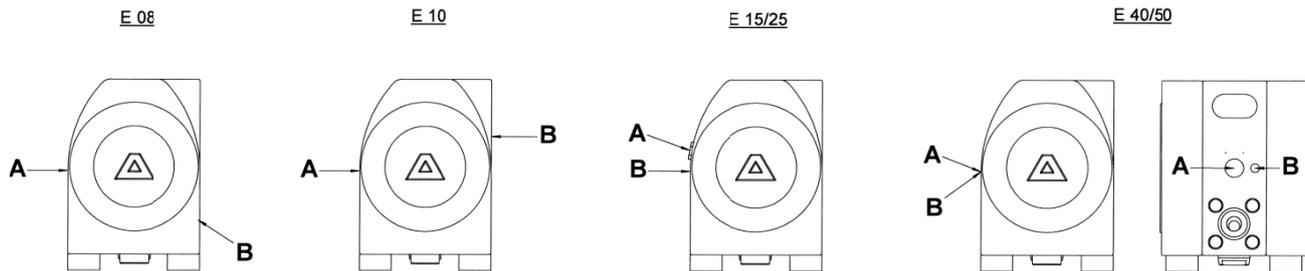

A = Air inlet for the pump, B = Air inlet for the pneumatic stroke counting system

Spare part list Stroke Counting				E 10	E 15	E 25	E 40	E 50	
Code	Item	Pc.	Description	Material	Part-No.	Part-No.	Part-No.	Part-No.	
C2	4*	1	Center housing for sensor:	PE	-	7 15 111 51	7 25 111 51	7 40 111 51	7 50 111 51
			- code E..	PE cond.	-	7 15 111 55	7 25 111 55	7 40 111 55	7 50 111 55
			- code F..	PTFE	-	7 15 111 60	7 25 111 60	7 40 111 60	7 50 111 60
			- code T..	PTFE cond.	-	7 15 111 65	7 25 111 65	7 40 111 65	7 50 111 65
-	50	1	Stroke sensor, Namur	diverse	-	1 00 072 99	1 00 072 99	1 00 072 99	1 00 072 99
			O-ring, stroke sensor	NBR	-	9 25 535 71	9 25 535 71	9 25 535 71	9 25 535 71
C3	-	1	as C 2, but additional:						
			Clamp amplifier	diverse	-	1 00 171 99	1 00 171 99	1 00 171 99	1 00 171 99
-	-	1	Stroke counter	diverse	-	10007199-01	10007199-01	10007199-01	10007199-01
C4	-	1	as C 2, but additional:						
			Controller	diverse	-	1 00 370 99	1 00 370 99	1 00 370 99	1 00 370 99
-	-	1	Stroke counter	diverse	-	10007199-01	10007199-01	10007199-01	10007199-01
C9	4*	1	Center housing with additional air connection R ¼:	PE	-	7 15 311 51	7 25 311 51	7 40 311 51	7 50 311 51
			- code E..	PE cond.	-	7 15 311 55	7 25 311 55	7 40 311 55	7 50 311 55
			- code F..	PTFE	7 10 311 60	7 15 311 60	7 25 311 60	7 40 311 60	7 50 311 60
			- code T..**	PTFE cond.	7 10 311 65	7 15 311 65	7 25 311 65	7 40 311 65	7 50 311 65
	-	1	Adaptor elbow (E 10 adaptor streight)	PP	1 00 877 51	1 00 875 51	1 00 875 51	1 00 875 51	1 00 875 51
-	1	Hose	PE	1 00 876 51	1 00 876 51	1 00 876 51	1 00 876 51	1 00 876 51	
-	1	Pressure switch cpl.	diverse	1 00 972 99	1 00 972 99	1 00 972 99	1 00 972 99	1 00 972 99	
-	1	Socket with cable	diverse	1 00 973 99	1 00 973 99	1 00 973 99	1 00 973 99	1 00 973 99	
C10	-	1	as C 9, but additional:						
-	-	1	Stroke counter	diverse	10007199-01	10007199-01	10007199-01	10007199-01	10007199-01

* Part-No. for center housings with ANSI connections on request

All parts in italics are not product wetted.

** Pump size E 08: 7 08 311 60

*** Pump size E 08: 7 08 311 65

Diaphragm monitoring (option code D 1, D 3)



Although ALMATEC diaphragms with integrated metal core are designed for an optimum service life, the diaphragm remains a wear part. If it breaks, liquid can leak into the center housing and possibly emerge through the muffler. This can be prevented simply and effectively with the ALMATEC diaphragm monitoring.

A capacitive diaphragm sensor is mounted in the muffler [25] of the pump, which registers any liquid approaching the sensor, no matter whether the liquid is conductive or not. Hence, a fast reaction to a damage of a diaphragm becomes possible. However, it has to be considered, that the diaphragm monitoring possibly

cannot prevent that liquid can leave the pump via the muffler. For higher safety requirements the ALMATEC barrier chamber system (optional equipment code BS) is recommended. In case of humid surrounding air a false alert may occur despite operating the pump with dried compressed air.

The diaphragm monitoring system is available in two variations:

- D 1 Diaphragm sensor (Namur), also for explosion proof area
- D 3 Diaphragm monitoring system complete with sensor and controller

The diaphragm sensor can either be connected to an existing controller with Namur inlet (code D 1) or to the controller included (code D 3). The wiring diagram and technical data can be found on the controller itself. For further details, please refer to the data delivered by the manufacturers of the components. The controllers have to be installed in a suitable cabinet.

Spare part list Diaphragm Monitoring					E 08	E 10	E 15	E 25	E 40	E 50
Code	Item	Pc.	Description	Material	Part-No.	Part-No.	Part-No.	Part-No.	Part-No.	Part-No.
D1	51	1	Diaphragm sensor, Namur	diverse	1 00 773 99	1 00 773 99	1 00 773 99	1 00 773 99	1 00 773 99	1 00 773 99
	-	1	Adapter, muffler	PE	6 10 033 52	-	-	-	-	-
D3	51	1	Diaphragm sensor, Namur	diverse	1 00 773 99	1 00 773 99	1 00 773 99	1 00 773 99	1 00 773 99	1 00 773 99
	-	1	Adapter, muffler	PE	6 10 033 52	-	-	-	-	-
	-	1	Trennschaltgerät	diverse	1 00 370 99	1 00 370 99	1 00 370 99	1 00 370 99	1 00 370 99	1 00 370 99

Special diaphragms (option code L + P)

Code L: Diaphragm made of conductive PTFE/EPDM-compound

For the use of the pumps in the device group IIC without flanking measures diaphragms made of conductive PTFE/EPDM compound are available.

Code P: Diaphragm made of modified PTFE

For media with increased diffusion tendency (e.g. benzene, solvents) as well as for application with priming out of a vacuum PTFE/EPDM compound diaphragms made of modified PTFE are available.

Spare part list Special Diaphragms					E 15	E 25	E 40	E 50
Code	Item	Pc.	Description	Material	Part-No.	Part-No.	Part-No.	Part-No.
L	18	2	Diaphragm made of conductive PTFE	PTFE cond. /EPDM	1 15 031 68	1 25 031 68	1 40 031 68	1 50 031 68
P	18	2	Diaphragm made of modified PTFE	PTFE modif. /EPDM	1 15 031 98	1 25 031 98	1 40 031 98	1 50 031 98

Center housing with ANSI connections (option code W)

As standard the connections in the center housing [4] are prepared for a DIN flange connection, but it is possible to order a preparation for ANSI flange connection also. So together with the appropriate code F ANSI flange connection with thread bushings and flange-O-rings is available.

Spare part list ANSI Center Housing					E 15	E 25	E 40	E 50
Code	Item	Pc.	Description	Material	Part-No.	Part-No.	Part-No.	Part-No.
W	4	1	Center housing ANSI, code E..	PE	7 15 411 51	7 25 411 51	7 40 411 51	7 50 411 51
			Center housing ANSI, code F..	PE conductive	7 15 411 55	7 25 411 55	7 40 411 55	7 50 411 55
			Center housing ANSI, code T..	PTFE	7 15 411 60	7 25 411 60	7 40 411 60	7 50 411 60
			Center housing ANSI, code U..	PTFE conductive	7 15 411 65	7 25 411 65	7 40 411 65	7 50 411 65

Flange connections (option code F 3, F 4, F 5)



This version offers the possibility to use flange connectors according to DIN/PN 10 or ANSI. Thread bushings made of stainless steel (code F3/F4/F5/F6 respective F3w/F4w/F5w/F6w for ANSI) to fix the flanges are included in the center housing. The O-rings attached have to be inserted into the grooves of the manifolds to improve sealing before connecting the pump. The O-rings, flanges [30] are made of EPDM (code F 3), FEP (code F 4), NBR (code F 5) or FKM (code F 6).

Pump size	E 15	E 25	E 40	E 50
Torque values for flange connections Nm (ft lbs)	4 (3)	5 (3.7)	12 (8.9)	15 (11.1)

Spare part list Flange Connection					E 15	E 25	E 40	E 50
Code	Item	Pc.	Description	Material	Part-No.	Part-No.	Part-No.	Part-No.
F3	-	12	Thread bushing, center housing DIN	1.4305	2 15 169 22	2 15 169 22	2 40 169 22	2 40 169 22
	30	2	Flange-O-ring, center housing DIN	EPDM	9 33 632 72	9 50 633 72	9 62 634 72	9 73 635 72
F3w	-	12	Thread bushing, center housing ANSI	1.4305	3 15 069 22	3 15 069 22	3 15 069 22	3 25 069 22
	30	2	Flange-O-ring, center housing ANSI	EPDM	9 23 588 72	9 40 613 72	9 62 634 72	9 73 635 72
F4	-	12	Thread bushing, center housing DIN	1.4305	2 15 169 22	2 15 169 22	2 40 169 22	2 40 169 22
	30	2	Flange-O-ring, center housing DIN	FEP/FKM	9 33 632 59	9 50 633 59	9 62 634 59	9 73 635 59
F4w	-	12	Thread bushing, center housing ANSI	1.4305	3 15 069 22	3 15 069 22	3 15 069 22	3 25 069 22
	30	2	Flange-O-ring, center housing ANSI	FEP/FKM	9 23 588 59	9 40 613 59	9 62 634 59	9 73 635 59
F5	-	12	Thread bushing, center housing DIN	1.4305	2 15 169 22	2 15 169 22	2 40 169 22	-
	30	2	Flange-O-ring, center housing DIN	NBR	9 33 632 71	9 50 633 71	9 62 634 71	-
F5w	-	12	Thread bushing, center housing ANSI	1.4305	3 15 069 22	3 15 069 22	3 15 069 22	-
	30	2	Flange-O-ring, center housing ANSI	NBR	9 23 588 71	9 40 613 71	9 62 634 71	-

Pumps for food contact (EG VO EC 1935/2004) (option code H)

ALMATEC pumps of the E-series were not design with regard to an effective cleaning; however they will be frequently used in the food industry. Pumps with the option code H are equipped with wetted parts, which are admitted for food contact according to EC 1935/2004. Such pumps will be delivered with a label and a conformity declaration.

Pumps prepared for using with a pulsation damper (option code TV)

ALMATEC pumps can be retrofitted with a pulsation damper even without changing of the piping. Divergent to the standard, pumps with the code TV are mounted in that way that they can be equipped with a pulsation damper without any reconstruction work on the pump (as described on page 31 of this manual). Special components are not part of this code. It has to be considered that pumps in this mounting condition have no suction connection at the bottom but one on the top, which is closed by a dummy plug.

Draining system (option code R 1, R 2, R 3, R 4, R 5, R 6)

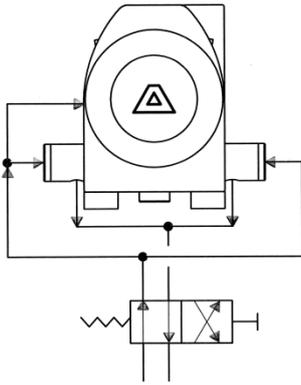

A pump equipped with the unique ALMATEC draining system can be emptied along with an inclining discharge line while being installed within the plant. The system is not appropriate to flush the pump with another liquid, nor from suction nozzle nor from discharge connection. It consists of a bypass-system in the side housings [1], which can be activated by manual valves (code R 1/R 2/R 5) or pneumatically (code R 3/R 4/R 6). Open the manual valves (code R 1/R 2/R 5) by approx. 10 mm by turning to the left (Attention: As there is no blocking of the valves, it has to be ensured not to take them out completely). The pump should be kept in operation meanwhile. Slow down the pump slowly and finally stop it. The drawing on the left illustrates the connection schedule for the air supply of a pump with the pneumatic draining system (code R 3/R 4/R 6, minimum air pressure 3 bar). By attaching a 4-2-way valve (not included in the delivery), the draining system can be activated automatically when cutting off the pump. The O-rings side housing are made of EPDM (code R 1/R 3), FEP (code R 2/R 4) or NBR (code R 5/R 6).

Spare part list Draining System					E 15	E 25	E 40	E 50
Code	Item	Pc.	Description	Material	Part-No.	Part-No.	Part-No.	Part-No.
R1	1	2	Side housing for back flushing system: - code E.. - code F.. - code T.. - code U..	PE PE cond. PTFE PTFE cond.	7 15 110 51 7 15 110 55 7 15 110 60 7 15 110 65	7 25 110 51 7 25 110 55 7 25 110 60 7 25 110 65	7 40 110 51 7 40 110 55 7 40 110 60 7 40 110 65	7 50 110 51 7 50 110 55 7 50 110 60 7 50 110 65
	31	2	O-ring, side housing	EPDM	9 20 631 72	9 20 631 72	9 33 632 72	9 33 632 72
	32	2	Drain plug	PTFE	2 15 023 60	2 15 023 60	2 40 023 60	2 40 023 60
	33	4	Plug	PTFE	7 15 022 60	7 15 022 60	7 40 022 60	7 40 022 60
R2	31	2	as R 1, but: O-ring, side housing	FEP/FKM	9 20 631 59	9 20 631 59	9 33 632 59	9 33 632 59
R3	32	2	as R 1, but: Piston	PTFE	2 15 024 60	2 15 024 60	2 40 024 60	2 40 024 60
	35	2	Piston housing	PE cond.	2 15 025 56	2 25 025 56	2 40 025 56	2 50 025 56
	36	2	Piston cover	PE cond.	2 15 026 55	2 15 026 55	2 40 026 55	2 40 026 55
	37	4	O-ring, piston and piston cover	NBR/EPDM	9 28 534 71	9 28 534 71	9 37 603 72	9 37 603 72
R4	31	2	as R 3, but: O-ring, side housing	FEP/FKM	9 20 631 59	9 20 631 59	9 33 632 59	9 33 632 59
R5	31	2	as R 1, but: O-ring, side housing	NBR	9 20 631 71	9 20 631 71	9 33 632 71	-
R6	31	2	as R 3, but: O-ring, side housing	NBR	9 20 631 71	9 20 631 71	9 33 632 71	-

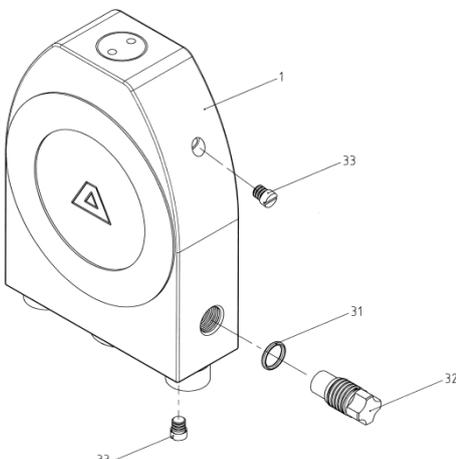

Draining system,
hand-operated
(Code R 1 / R 2 / R 5)

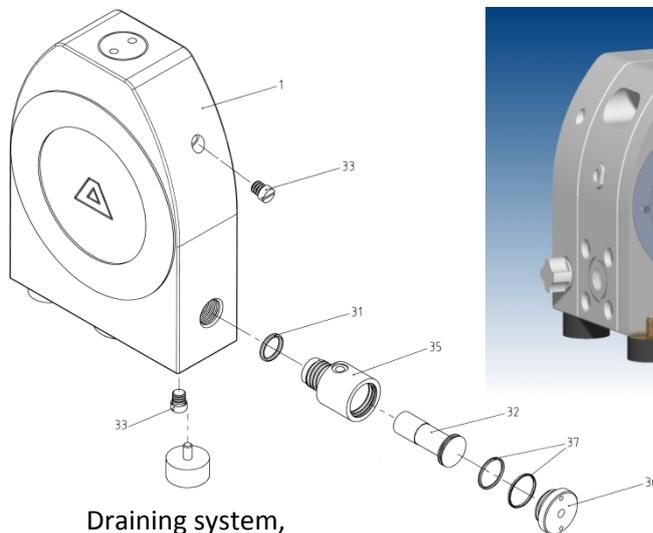

Draining system,
pneumatic
(Code R 3 / R 4 / R 6)

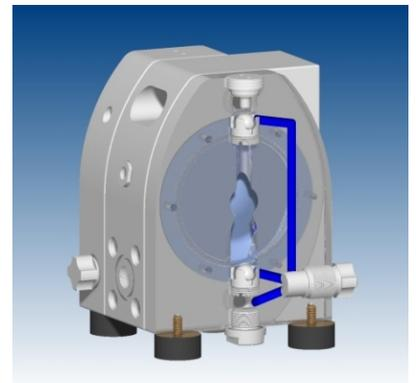

Pumps with PTFE diaphragms and FKM housing gaskets (option code V)

FKM gaskets offer widespread chemical resistance to cover the major part of applications requiring PTFE diaphragms (check compatibility) and combine this with high elasticity for good sealing and a reasonable price. (FKM is offered under various brand names, of which Viton®, a registered trademark of DuPont, is the most commonly known).

Spare part list pump code TT.-V					E 08	E 10	E 15	E 25	E 40	E 50
Code	Item	Pc.	Description	Material	Part-No.	Part-No.	Part-No.	Part-No.	Part-No.	Part-No.
V	6	8	O-ring, sleeve	FKM	9 12 629 75	9 15 630 75	9 20 631 75	9 33 632 75	9 50 633 75	9 62 634 75
	10	2	O-ring, valve stop discharge valve	FKM	9 16 623 75	9 19 624 75	9 24 625 75	9 38 626 75	9 57 627 75	9 76 628 75
	12	2	O-ring, plug side housing	FKM	9 14 178 75	9 20 602 75	9 25 610 75	9 40 613 75	9 62 634 75	9 79 353 75
	14	1	O-ring, plug center housing.	FKM	9 20 631 75	9 20 631 75	9 33 632 75	9 50 633 75	9 62 634 75	9 73 635 75

External control (option code Z)

Such a pump has neither an air control system nor a muffler, but can be controlled externally via a solenoid valve. The center housing has two separate air connections to ventilate and exhaust both working chambers. The solenoid valve is not part of the delivery. If the pump is equipped with this code, a separate spare part list is attached. Dimensions regarding the location of the air connections on request.

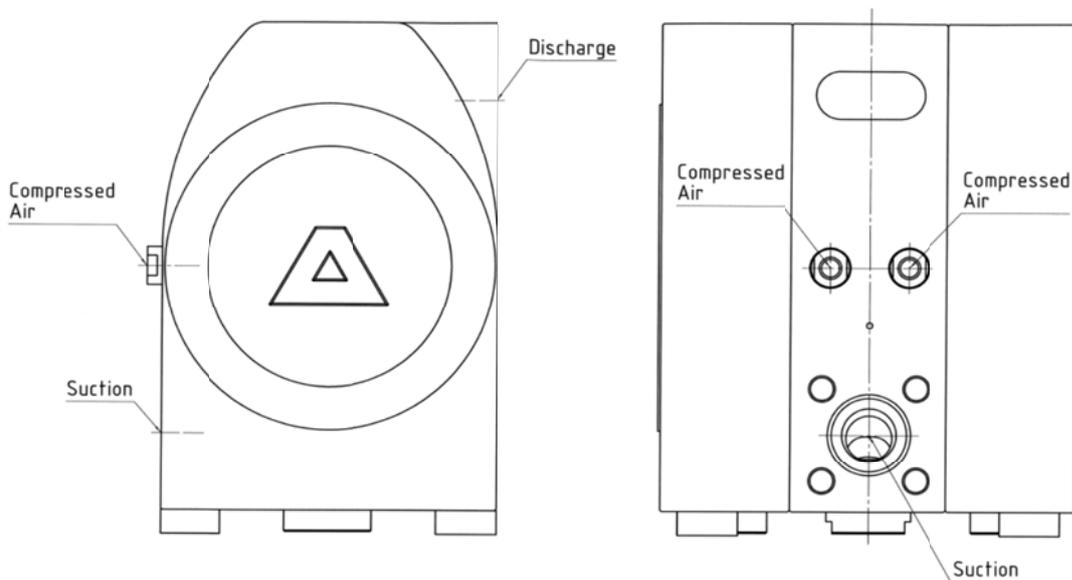

More options

Code OG: Product connections without inner threads

Code X: Customized pump solutions

In these cases a separate spare part list is attached to this manual.

DIMENSIONS

Dimensions E-Series with optional equipment

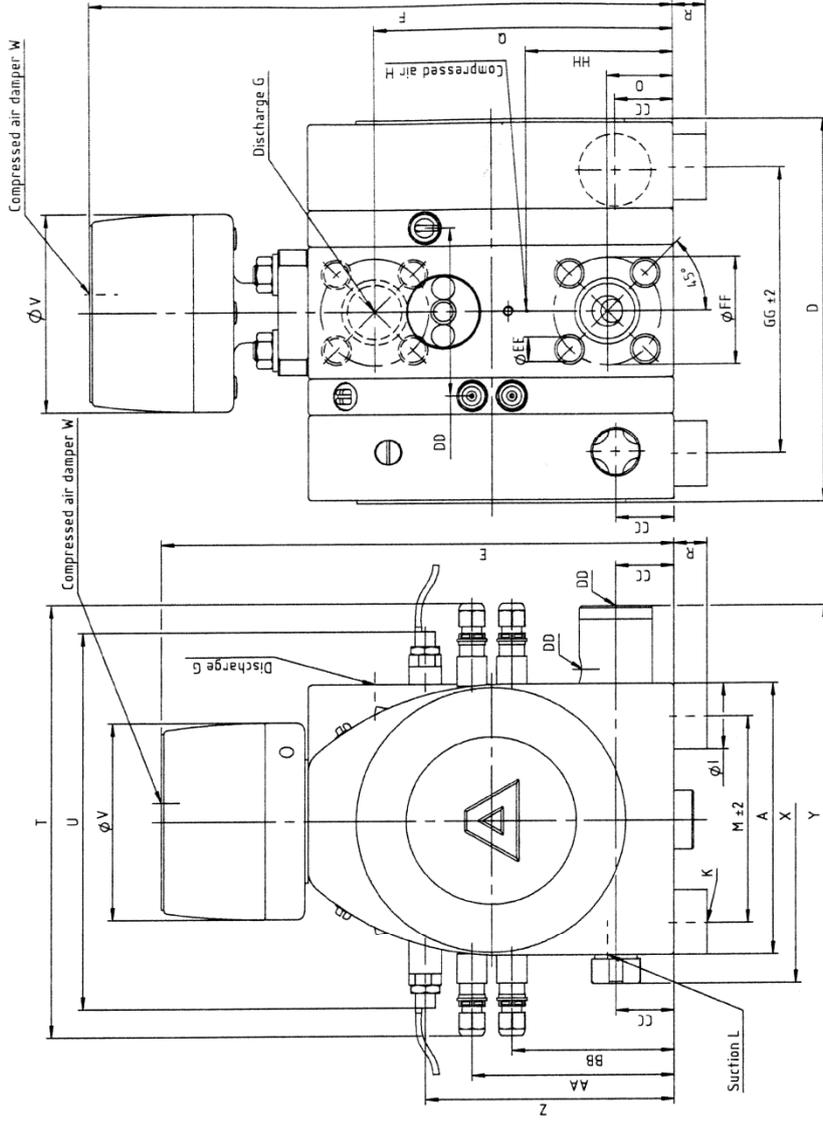

Dimensions E-Series Standard

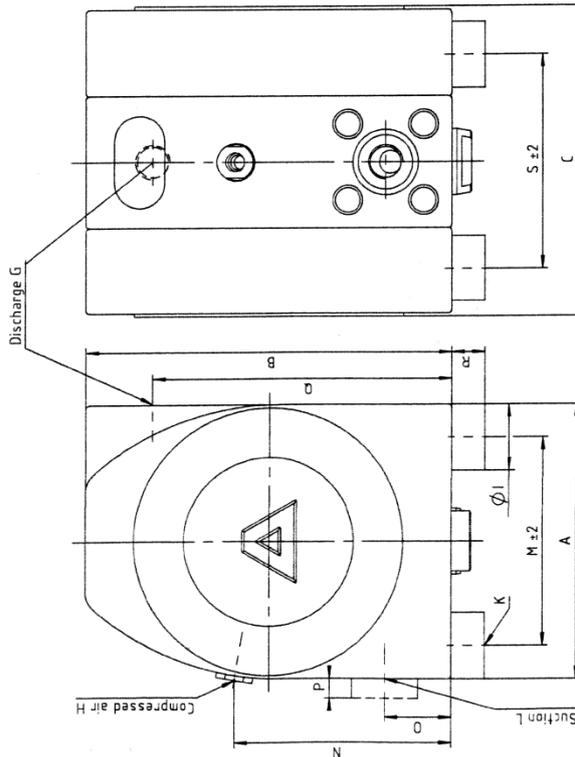

mm	A	B	C	D	E	F	G	H	I	K	L	M	N	O	P	Q	R	S	T	U	V	W	X	Y	Z	AA	BB	CC	DD	EE	FF	GG	HH
E 08	90	116	128	-	195	-	1/4"	1/8"	25	M6	1/4"	50	58	15	10	101	13	84	-	-	85	1/8"	-	-	-	-	-	-	-	-	-	-	58
E 10	110	156	147	189	235	-	3/8"	1/8"	25	M6	3/8"	85	78	17	11	139	13	97	208	202	85	1/8"	-	-	-	96	90	66	-	-	-	139	78
E 15	166	220	189	233	309	352	1/2"	1/4"	40	M8	1/2"	126	131	40	12	180	20	130	264	230	120	1/8"	201	262	150	122	98	35	102	M12	65	174	89
E 25	220	300	255	301	433	476	1"	1/4"	40	M8	1"	180	178	48	18	252	20	185	318	272	170	1/8"	252	316	205	163	137	49	118	M12	85	231	122
E 40	280	412	353	401	574	627	1-1/2"	1/2"	50	M10	1-1/2"	230	206	65	18	347	20	270	378	310	220	1/4"	316	374	296	219	193	72	154	M16	110	318	206
E 50	360	532	430	482	754	812	2"	1/2"	50	M10	2"	310	266	80	18	452	20	340	458	374	285	1/4"	392	454	391	279	253	82	186	M16	125	392	266

G = NPT, H + W = BSP

inch	A	B	C	D	E	F	G	H	I	K	L	M	N	O	P	Q	R	S	T	U	V	W	X	Y	Z	AA	BB	CC	DD	EE	FF	GG	HH	
E 08	3.5	4.6	5.0	-	7.7	-	1/4"	1/8"	1.0	M6	1/4"	2.0	2.3	0.6	0.4	4.0	0.5	3.3	-	-	3.3	1/8"	-	-	-	-	-	-	-	-	-	-	-	2.3
E 10	4.3	6.1	5.8	7.4	9.3	-	3/8"	1/8"	1.0	M6	3/8"	3.3	3.1	0.7	0.4	5.5	0.5	3.8	8.2	8.0	3.3	1/8"	-	-	-	3.8	3.5	2.6	-	-	-	-	3.1	
E 15	6.5	8.7	7.4	9.2	12.2	13.9	1/2"	1/4"	1.6	M8	1/2"	5.0	5.2	1.6	0.5	7.1	0.8	5.1	10.4	9.1	4.7	1/8"	7.9	10.3	5.9	4.8	3.9	1.4	4.0	M12	2.6	6.9	3.5	
E 25	8.7	11.8	10.0	11.9	17.0	18.7	1"	1/4"	1.6	M8	1"	7.1	7.0	1.9	0.7	9.9	0.8	7.3	12.5	10.7	6.7	1/8"	9.9	12.4	8.1	6.4	5.4	1.9	4.6	M12	3.3	9.1	4.8	
E 40	11.0	16.2	13.9	15.8	22.6	24.7	1-1/2"	1/2"	2.0	M10	1-1/2"	9.1	8.1	2.6	0.7	13.7	0.8	10.6	14.9	12.2	8.7	1/4"	12.4	14.7	11.7	8.6	7.6	2.8	6.1	M16	4.3	12.5	8.1	
E 50	14.2	20.9	16.9	19.0	29.7	32.0	2"	1/2"	2.0	M10	2"	12.2	10.5	3.1	0.7	17.8	0.8	13.4	18.0	14.7	11.2	1/4"	15.4	17.9	15.4	11.0	10.0	3.2	7.3	M16	4.9	15.4	10.5	

ALMATEC PULSATION DAMPERS, ET Series and ET-F Series

The ALMATEC pulsation dampers series ET and ET-F represents the latest generation of active pulsation dampers. They are specially designed to be used along with ALMATEC air-operated double diaphragm pumps of the E-Series. A general aspect to be considered is, that a pulsation damper decreases the total capacity of the system depending on the point of operation.

Before putting an ALMATEC pulsation damper into operation, make sure, that the materials of construction are resistant to the chemical to be pumped. To check this, the exact damper code is required. This code, the serial number and the year of construction are noted on the identification plates on the damper itself.

Example of the damper type code:

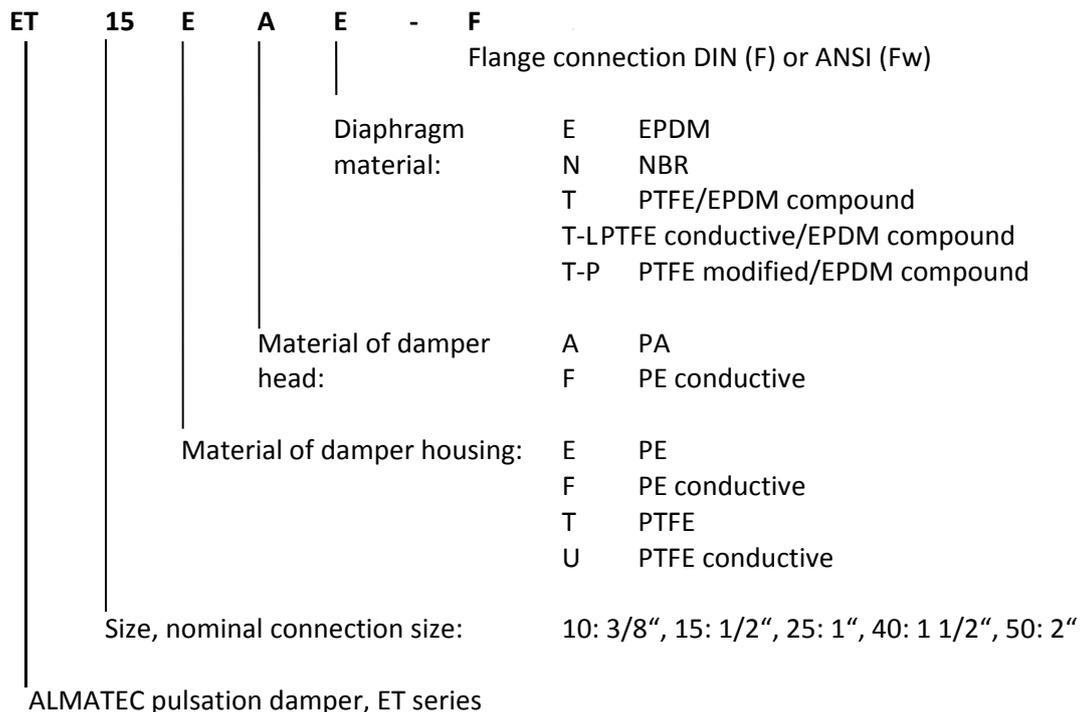

Air supply connection: ET 10 - ET 25: R 1/8", ET 40 / ET 50: R 1/4"

Max. operating pressure: 7 bar / 100 psig

Max. operating temperature: for damper housing in PE 70°C/158°F
for damper housing in PTFE size ET 10 100°C/212°F, for the other sizes 120°C/248°F (with damper head in PE conductive 80°C/176°C)

For flammable liquids as well as for applications in explosion protected areas, only dampers made of conductive plastic materials (code F resp. U) may be used. It is not necessary to ground the damper separately, as the damper is connected conductively to the E-Series pump, which is conductive and has to be grounded itself (please see ATEX hints on page 4).

In general, pump and damper are dispatched completely mounted. Still, they can be packed in separate boxes, especially for the bigger sizes. If so, the damper has to be screwed into the thread at the top of the center housing carefully, but only until the damper is in contact with the pump. Exceeded tightening may damage the thread. Besides, a correct positioning of the O-ring [10] within the groove has to be ensured.

An ALMATEC ET-damper can easily be attached to an E-Series pump at any time without changes of the piping, provided that the pump is configurated with product ports both horizontally. Make sure that the plug, center housing (item 13 in the exploded view of the pump) is in the right position. For pumps delivered

without dampers, this plug can be found at the bottom side of the pump generally. Therefore, the center housing has to be turned 180°, to get the plug to the top of the pump. Take the plug out, insert the flange-O-ring [10] and screw the damper onto the pump. When dismantling a pump which is already being in use, take care of the warning advices on pages 8/9 of this manual.

Before connecting the pump, take the yellow blind plugs out of air inlet which is located on the top of the damper head [3]. For correct operation, the damper absolutely needs an air-supply of its own, which has to be taken from the air-supply of the pump. Pump and pulsation damper have to be connected to the same air pressure. No stop or regulating valve may be placed between pump and damper. The driving air has to be oil-

free, dry and clean. The damper requires a minimum counter pressure of at least 1 bar for optimal function. Together with the pump an empty damper has to be driven slowly. The dampers are self-regulating for all changing operating conditions.

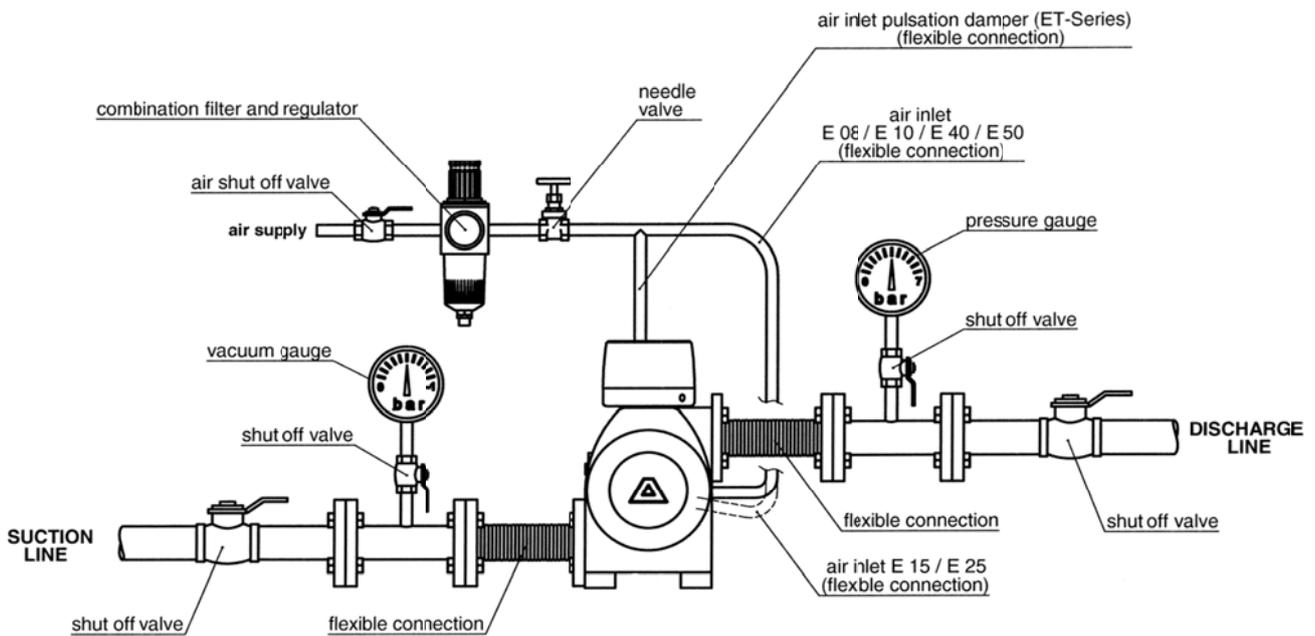

- Do not use any threadseal for the connection of pump and damper, otherwise the threads could be damaged.
- Before putting the pulsation damper into operation as well as after some hours of operating, the housing bolts [6] have to be tightened according to the torque data of the following schedule, as the elements of construction tend to "settle". Fixing the bolts is necessary as well after longer periods of stoppage, at extreme temperature variations, transport and after dismantling.
- Pressure tests of the plant a pump and a damper are included in may only be carried out with the aggregate (pump and damper) disconnected from the pressure on both ports or by using the pressure the aggregate develops while operating. The load of a pressure in the plant may damage the pump and the pulsation damper.
- Before starting to disassemble the pump, take care that pump and damper have been emptied and rinsed. Further both have to be cut off from any energy on the air and product side. If pump and damper is being deported from the plant, a reference about the delivered liquid has to be attached.
- Please respect the relevant additional security advices, if the pump and the damper have been used for aggressive, dangerous or toxic liquids.
- Before putting the pump and the damper back into operation, the tightness of both has to be checked.
- For further warning instructions, please refer to the pages 10-11.

Damper size		ET 10	ET 15	ET 25	ET 40	ET 50
Torque values for damper housing bolts						
Nm (ft lbs):	PE damper	-	3 (2.2)	6 (4.4)	10 (7.4)	11 (8.1)
	PTFE damper	2 (1.5)	3 (2.2)	6 (4.4)	10 (7.4)	11 (8.1)

Hints for disassembly of an ET pulsation damper

Pull out the cover [5]. Unscrew housing bolts [6] carefully. After that, all parts can be removed. Screw the diaphragm [2] off the actuator shaft [7]. A re-assembly of used piston rings [8] is impossible; they have to be replaced including the O-rings underneath. In the well of the actuator shaft [7] are five grooves of which is in the first, third and fifth a piston ring. To assemble new piston rings [8] carefully shape them like kidneys with locking ring pliers and insert the rings into the grooves; completely press the rings into the grooves smoothly using some round tool.

Spare part list Damper ET				ET 10	ET 15	ET 25	ET 40	ET 50	
Item	Pc.	Description	Material	Part-No.	Part-No.	Part-No.	Part-No.	Part-No.	
1	1	Damper housing, code E..	PE	-	7 15 080 52	7 25 080 52	7 40 080 52	7 50 080 52	
		Damper housing, code F..	PE conductive	-	7 15 080 56	7 25 080 56	7 40 080 56	7 50 080 56	
		Damper housing, code T..	PTFE	7 10 080 69	7 15 080 69	7 25 080 69	7 40 080 60	7 50 080 60	
		Damper housing, code U..	PTFE conductive	7 10 080 68	7 15 080 68	7 25 080 68	7 40 080 65	7 50 080 65	
2	1	Diaphragm, code ..E	EPDM	-	1 10 031 72	1 15 031 72	1 25 031 72	1 40 031 72	
		Diaphragm, code ..N	NBR	-	1 10 031 70	1 15 031 70	1 25 031 70	1 40 031 70	
		Diaphragm, code ..T	PTFE	1 08 031 67	1 10 031 67	1 15 031 67	1 25 031 67	1 40 031 67	
		Diaphragm, code ..T - L	PTFE conductive	-	-	1 15 031 68	1 25 031 68	1 40 031 68	
		Diaphragm, code ..T - P	PTFE modified	-	-	1 15 031 98	1 25 031 98	1 40 031 98	
3	1	<i>Damper head, code .A.</i>	<i>PA</i>	<i>7 10 081 53</i>	<i>7 15 081 53</i>	<i>7 25 081 53</i>	<i>7 40 081 53</i>	<i>7 50 081 53</i>	
		<i>Damper head, code .F.</i>	<i>PE conductive</i>	<i>7 10 081 55</i>	<i>7 15 081 55</i>	<i>7 25 081 55</i>	<i>7 40 081 55</i>	<i>7 50 081 55</i>	
4	1	<i>Tension disc</i>	<i>1.4301</i>	<i>7 08 008 22</i>	<i>7 10 008 22</i>	<i>7 15 008 22</i>	<i>7 25 008 22</i>	<i>7 40 008 22</i>	
5	1	<i>Cover, code .A.</i>	<i>PE</i>	<i>7 08 009 51</i>	<i>7 10 009 51</i>	<i>7 15 009 51</i>	<i>7 25 009 51</i>	<i>7 40 009 51</i>	
		<i>Cover, code .F.</i>	<i>PE conductive</i>	<i>7 08 009 55</i>	<i>7 10 009 55</i>	<i>7 15 009 55</i>	<i>7 25 009 55</i>	<i>7 40 009 55</i>	
6	*	<i>Housing bolt, cpl.</i>	<i>1.4301</i>	<i>7 10 083 22</i>	<i>7 15 083 22</i>	<i>7 25 083 22</i>	<i>7 40 083 22</i>	<i>7 50 083 22</i>	
7	1	<i>Actuator shaft</i>	<i>1.4301</i>	<i>1 08 482 22</i>	<i>1 10 482 22</i>	<i>1 15 482 22</i>	<i>1 25 482 22</i>	<i>1 40 482 22</i>	
8	3	<i>Shaft piston ring, cpl.</i>	<i>PTFE</i>	<i>1 08 041 64</i>	<i>1 08 041 64</i>	<i>1 15 041 64</i>	<i>1 25 041 64</i>	<i>1 40 041 64</i>	
9	1	<i>Muffler</i>	<i>PE</i>	<i>1 08 644 51</i>	<i>1 08 644 51</i>	<i>1 15 644 51</i>	<i>1 25 644 51</i>	<i>1 40 644 51</i>	
10	1	Flange-O-ring, center housing DIN:							
		- code ..E	EPDM	9 20 631 72	9 33 632 72	9 50 633 72	9 62 634 72	9 73 635 72	
		- code ..N	NBR	-	9 33 632 71	9 50 633 71	9 62 634 71	9 73 635 71	
		- code ..T	FEP/FKM	9 20 631 59	9 33 632 59	9 50 633 59	9 62 634 59	9 73 635 59	
		- code ..T-V	FKM	9 20 631 75	9 33 632 75	9 50 633 75	9 62 634 75	9 73 635 75	
		Flange-O-ring, center housing ANSI:							
		- code ..E	EPDM	9 20 631 72	9 23 588 72	9 40 613 72	9 62 634 72	9 73 635 72	
		- code ..N	NBR	-	9 23 588 71	9 40 613 71	9 62 634 71	9 73 635 71	
- code ..T	FEP/FKM	9 20 631 59	9 23 588 59	9 40 613 59	9 62 634 59	9 73 635 59			
- code ..T-V	FKM	9 20 631 75	9 23 588 75	9 40 613 75	9 62 634 75	9 73 635 75			

* ET 10 and ET 15: 4 pieces; ET 25 and ET 40: 6 pieces; ET 50: 8 pieces

All parts in italics are not product wetted.

Dimensions pulsation damper ET

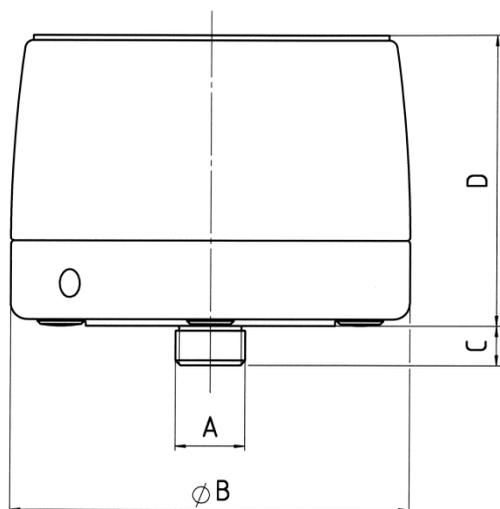

mm (inch)	A	B	C	D
ET 10	NPT 3/8"	85 (3.3)	11 (0.4)	79 (3.1)
ET 15	NPT 1/2"	120 (4.7)	12 (0.5)	89 (3.5)
ET 25	NPT 1"	170 (6.7)	14 (0.6)	133 (5.2)
ET 40	NPT 1-1/2"	220 (8.7)	16 (0.6)	162 (6.4)
ET 50	NPT 2"	285 (11.2)	18 (0.7)	222 (8.7)

Exploded view pulsation damper ET

Pos. / Item 6: ET 10 / ET 15 - 4 x
 ET 25 / ET 40 - 6 x
 ET 50 - 8 x

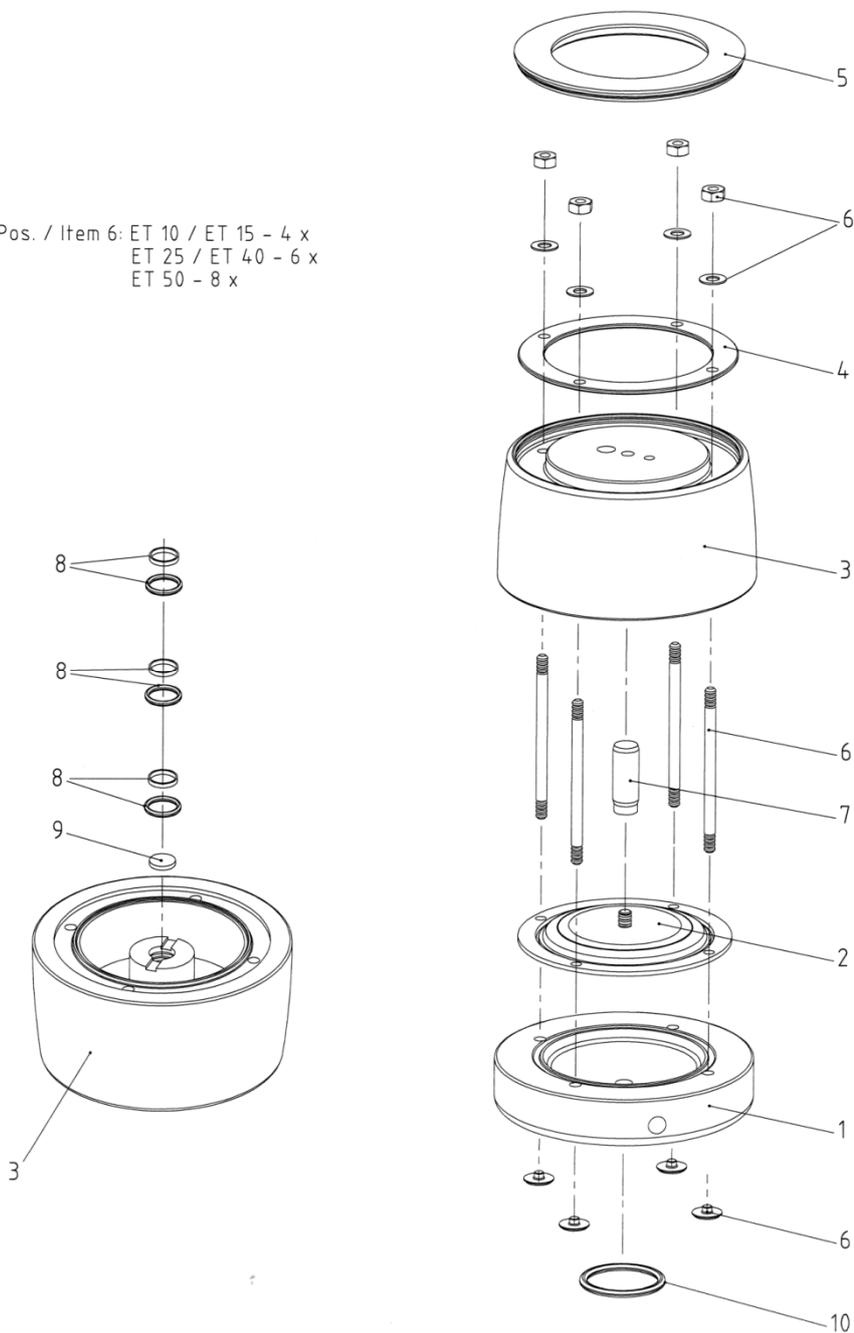

Additional hints for pulsation damper series ET-F (flange version)

Beside the screwed pulsation damper as standard flange versions (series ET-F) are available also. In general, pump and damper are dispatched completely mounted. Still, they can be packed in separate boxes, especially for the bigger sizes. If so, use the attached nuts, set screws, washers and discs [11-14] to flange the damper to the pump.

Pump size	ET 15	ET 25	ET 40	ET 50
Torque values for flange connections Nm (ft lbs):	4 (3)	5 (3.7)	12 (8.9)	15 (11.1)

Spare part list Flange Damper ET-F				ET 15 - F	ET 25 - F	ET 40 - F	ET 50 - F
Item	Pc.	Description	Material	Part-No.	Part-No.	Part-No.	Part-No.
1	1	Damper housing DIN, code E..	PE	7 15 180 52	7 25 180 52	7 40 180 52	7 50 180 52
		Damper housing DIN, code F..	PE conductive	7 15 180 56	7 25 180 56	7 40 180 56	7 50 180 56
		Damper housing DIN, code T..	PTFE	7 15 180 69	7 25 180 69	7 40 180 69	7 50 180 69
		Damper housing DIN, code U..	PTFE cond.	7 15 180 68	7 25 180 68	7 40 180 68	7 50 180 68
		Damper housing ANSI, code E..-W	PE	7 15 280 52	7 25 280 52	7 40 280 52	7 50 280 52
		Damper housing ANSI, code F..-W	PE conductive	7 15 280 56	7 25 280 56	7 40 280 56	7 50 280 56
		Damper housing ANSI, code T..-W	PTFE	7 15 280 69	7 25 280 69	7 40 280 69	7 50 280 69
		Damper housing ANSI, code U..-W	PTFE cond.	7 15 280 68	7 25 280 68	7 40 280 68	7 50 280 68
2	1	Diaphragm, code ..E	EPDM	1 10 031 72	1 15 031 72	1 25 031 72	1 40 031 72
		Diaphragm, code ..N	NBR	1 10 031 70	1 15 031 70	1 25 031 70	1 40 031 70
		Diaphragm, code ..T	PTFE	1 10 031 67	1 15 031 67	1 25 031 67	1 40 031 67
		Diaphragm, code ..T - L	PTFE cond.	-	1 15 031 68	1 25 031 68	1 40 031 68
		Diaphragm, code ..T - P	PTFE mod.	-	1 15 031 98	1 25 031 98	1 40 031 98
3	1	<i>Damper head, code .A.</i>	<i>PA</i>	<i>7 15 081 53</i>	<i>7 25 081 53</i>	<i>7 40 081 53</i>	<i>7 50 081 53</i>
		<i>Damper head, code .F.</i>	<i>PE conductive</i>	<i>7 15 081 55</i>	<i>7 25 081 55</i>	<i>7 40 081 55</i>	<i>7 50 081 55</i>
4	1	<i>Tension disc</i>	<i>1.4301</i>	<i>7 10 008 22</i>	<i>7 15 008 22</i>	<i>7 25 008 22</i>	<i>7 40 008 22</i>
5	1	<i>Cover, code .A.</i>	<i>PE</i>	<i>7 10 009 51</i>	<i>7 15 009 51</i>	<i>7 25 009 51</i>	<i>7 40 009 51</i>
		<i>Cover, code .F.</i>	<i>PE conductive</i>	<i>7 10 009 55</i>	<i>7 15 009 55</i>	<i>7 25 009 55</i>	<i>7 40 009 55</i>
6	*	<i>Housing bolt, cpl.</i>	<i>1.4301</i>	<i>7 15 083 22</i>	<i>7 25 083 22</i>	<i>7 40 083 22</i>	<i>7 50 083 22</i>
7	1	<i>Actuator shaft</i>	<i>1.4301</i>	<i>1 10 482 22</i>	<i>1 15 482 22</i>	<i>1 25 482 22</i>	<i>1 40 482 22</i>
8	3	<i>Shaft piston ring, cpl.</i>	<i>PTFE</i>	<i>1 08 041 64</i>	<i>1 15 041 64</i>	<i>1 25 041 64</i>	<i>1 40 041 64</i>
9	1	<i>Muffler</i>	<i>PE</i>	<i>1 08 644 51</i>	<i>1 15 644 51</i>	<i>1 25 644 51</i>	<i>1 40 644 51</i>
10	1	Flange-O-ring, center housing DIN, code ..E	EPDM	9 20 631 72	9 33 632 72	9 50 633 72	9 62 634 72
		Flange-O-ring, center housing DIN, code ..N	NBR	-	9 33 632 71	9 50 633 71	9 62 634 71
		Flange-O-ring, center housing DIN, code ..T	FEP/FKM	9 20 631 59	9 33 632 59	9 50 633 59	9 62 634 59
		Flange-O-ring, center housing DIN, code ..T-V	FKM	9 20 631 75	9 33 632 75	9 50 633 75	9 62 634 75
		Flange-O-ring, center housing ANSI, code ..E	EPDM	9 20 631 72	9 23 588 72	9 40 613 72	9 62 634 72
		Flange-O-ring, center housing ANSI, code ..N	NBR	-	9 23 588 71	9 40 613 71	9 62 634 71
		Flange-O-ring, center housing ANSI, code ..T	FEP/FKM	9 20 631 59	9 23 588 59	9 40 613 59	9 62 634 59
		Flange-O-ring, center housing ANSI, code ..T-V	FKM	9 20 631 75	9 23 588 75	9 40 613 75	9 62 634 75
11	4	<i>Hexagon nut DIN 934, DIN-flange</i>	<i>1.4305</i>	<i>9 12 101 22</i>	<i>9 12 101 22</i>	<i>9 16 101 22</i>	<i>9 16 101 22</i>
		<i>Hexagon nut DIN 934, ANSI-flange</i>		<i>15-6420-03</i>	<i>15-6420-03</i>	<i>15-6420-03</i>	<i>15-6430-03</i>
12	4	<i>Set screw DIN 913, DIN-flange</i>	<i>1.4305</i>	<i>9 12 225 22</i>	<i>9 12 225 22</i>	<i>9 16 226 22</i>	<i>9 16 227 22</i>
		<i>Set screw, ANSI-flange</i>		<i>9 12 955 22</i>	<i>9 12 955 22</i>	<i>9 12 965 22</i>	<i>9 16 970 22</i>
13	4	<i>Spring washer DIN 2093, DIN-flange</i>	<i>1.4301</i>	<i>9 12 154 22</i>	<i>9 12 154 22</i>	<i>9 16 154 22</i>	<i>9 16 154 22</i>
		<i>Spring washer, ANSI-flange</i>		<i>9 14 154 22</i>	<i>9 14 154 22</i>	<i>9 14 154 22</i>	<i>9 16 154 22</i>
14	4	<i>Disc DIN 125, DIN-flange</i>	<i>1.4301</i>	<i>9 13 151 22</i>	<i>9 13 151 22</i>	<i>9 17 151 22</i>	<i>9 17 151 22</i>
		<i>Disc DIN 125, ANSI-flange</i>		<i>9 13 151 22</i>	<i>9 13 151 22</i>	<i>9 13 151 22</i>	<i>9 17 151 22</i>

*ET 15 -F: 4 pieces; ET 25 -F and ET 40 -F: 6 pieces; ET 50 -F: 8 pieces

All parts in italics are not product wetted.

Dimensions pulsation damper ET-F (flange version)

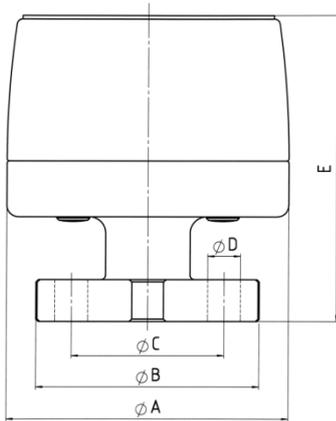

mm (inch)	A	B	C	D	E
ET 15 - F	120 (4.7)	95 (3.7)	65 (2.6)	14 (0.6)	132 (5.2)
ET 25 - F	170 (6.7)	115 (4.5)	85 (3.3)	14 (0.6)	176 (6.9)
ET 40 - F	220 (8.7)	150 (5.9)	110 (4.3)	18 (0.7)	215 (8.5)
ET 50 - F	285 (11.2)	165 (6.5)	125 (4.9)	18 (0.7)	280 (11.0)

Exploded view pulsation damper ET-F (flange version)

Pos. / Item 6: ET 15-F - 4 x
 ET 25-F / ET 40-F - 6 x
 ET 50-F - 8 x

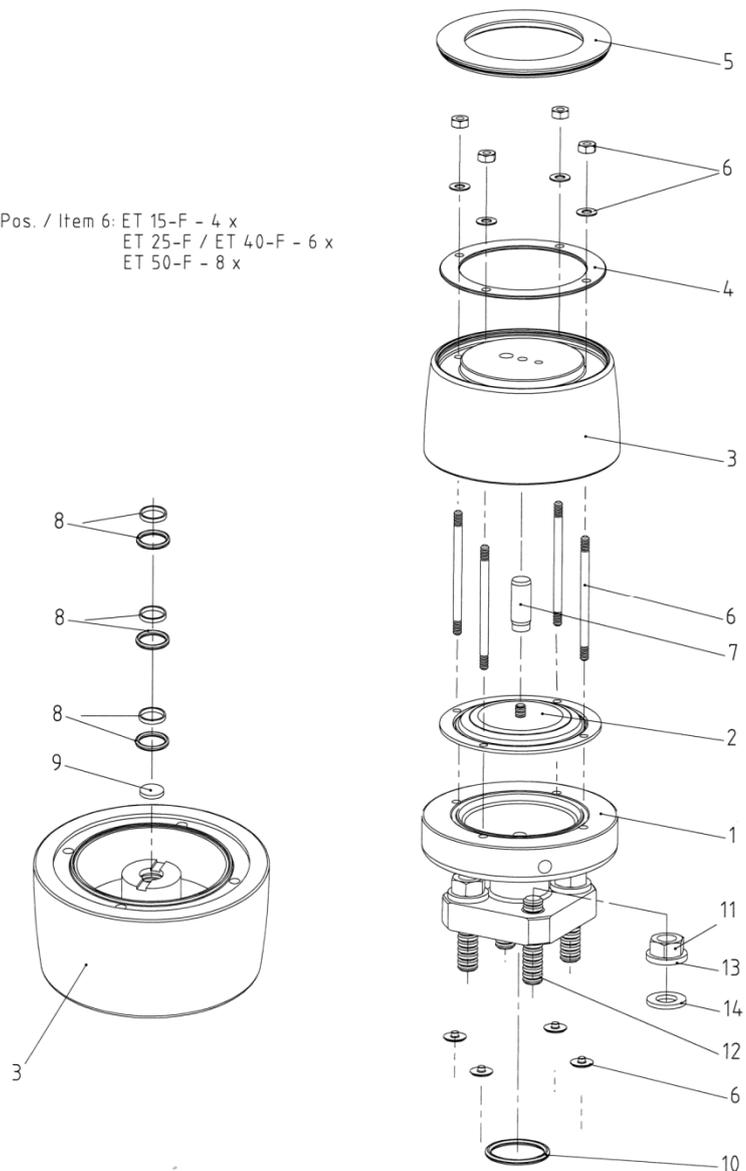

Subject to change without notice, 2016/01 (replaces 2013/05)

ALMATEC Maschinenbau GmbH
 Carl-Friedrich-Gauss-Str. 5 · 47475 Kamp-Lintfort · Germany
 Telephone ++49.2842.9610 · Telefax ++49.2842.96140
<http://www.almatec.de> · e-mail: info@almatec.de