

DRY CR 60
DRY CR 150
DRY CR 400
DRY CR 500
DRY CR 1000
Claw vacuum pumps

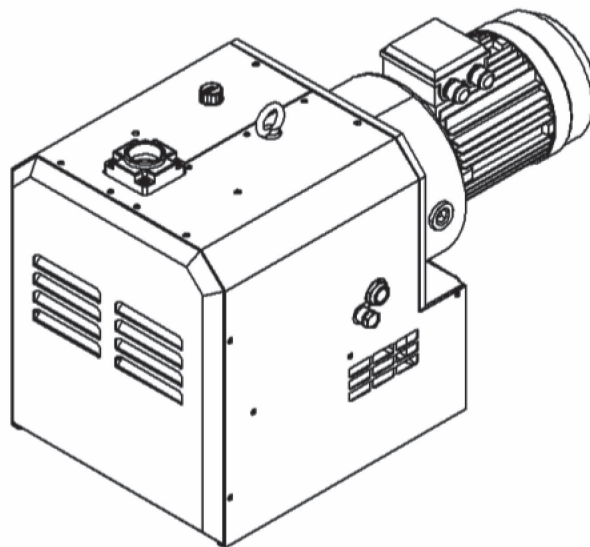

***Operating and maintenance
instructions***

Publication Number:
LI 4947.P0 November 2020

Operating and maintenance instructions

EN

Index

1. General information	page 3
2. Installation	page 4
2.1 Pump description	page 4
2.2 Unpacking	page 4
2.3 Location	page 4
2.4 Power Requirements	page 5
2.5 Vacuum Connections	page 6
2.6 Oil Filling on Gear Box.....	page 7
3. Safety	page 8
3.1 General Notices	page 8
3.2 Warning labels and their explanations	page 8
3.3 Location of the labels	page 8
4. Operation	page 9
4.1 Start-up	page 9
4.2 Stopping the pump.....	page 9
4.3 Operating Conditions	page 9
5. Maintenance	page 10
5.1 Gear Box Lube Oil.....	page 10
5.2 Inline (Inlet) Filter	page 11
5.3 Maintenance Chart	page 12
6. Troubleshooting	page 12
7. De-commissioning	page 14
8. Return for repair	page 14
9. Disposal	page 15
Attachments	
Technical data sheet, exploded view and parts list (RDT)	
EC declaration of conformity (DC)	
Electric motor operating instructions	
Instructions for the accessories	

1. General information

This manual contains information necessary for the proper operation of the pump in order to prevent unsuitable use and for the safety of the operators. Do not attempt any other type of operation without having first contacted our **Service Department**. The information provided herewith does not intend to replace, integrate or change any rules, regulations, law by decree, directive or law of specific character in force in the Country where the installation takes place.

The suggestions given to the staff engaged in the installation and servicing assumes that the personnel is expert and prepared in facing any problem of servicing, both mechanical and electrical. For any questions or information not included in this manual, please contact our Service Department, always providing: model (Model), serial number (Serial), year of manufacture, stated on the pump name plate.

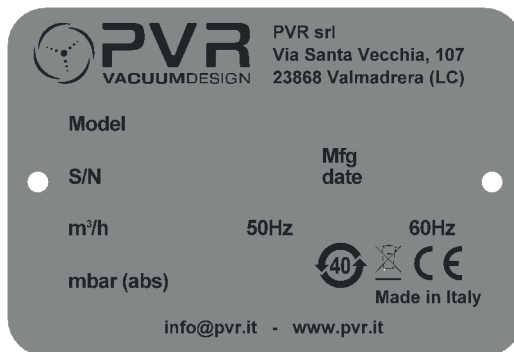

Symbols used:



WARNING:
Instructions that, if not followed,
could result in serious
personal injuries.



ELECTRIC SAFETY



NOTE:
Instructions that, if not followed,
could result in pump damages.



FIRE HAZARD



**READ THE OPERATING
INSTRUCTIONS**



HOT SURFACES



DISPOSAL



**HARMFUL SUBSTANCES
EMISSIONS**



**DO NOT DISPOSE INTO
THE ENVIRONMENT**

2. Installation

2.1 Pump description

The DRY CR compressor is dry and contactless machines, enclosed in acoustic sound shield and designed to have cooling air passed through the sound shield by fan. The warm air is exhausted through the vent. The DRY CR is constructed in modular construction consisting of two compartments: pumping and gear chambers separated by using labyrinth seals. In the pump chamber, as two rotary claws rotate in opposite direction, the air sucked in, shall be compressed and discharged under pressure. In the gear chamber (box), two gears for synchronizing of claws rotation will be located with oil lubrication. For reduction of the noise, inlet silencer shall be installed in compressor inlet side. For a protection of overload, a pressure safety valve or regulating valve is installed in exhaust. The compressors are directly driven by a flanged motor via a coupling. The DRY CR Series compressors are identical in internal construction to DRY CR vacuum pump, but are outfitted with different inlet and outlet accessories to allow for operation as a compressor.

2.2 Unpacking

Inspect the box and the vacuum pumps carefully for any signs of damage incurred in transit. Since all vacuum pumps are ordinarily shipped F. O. B. from our factory or regional warehouse, such damage is the normal responsibility of the carrier and should be reported to them.

The vacuum pump is bolted to the skid with studs that are connected through the rubber feet of the pump. Remove the nuts from the underside of the crate and remove the vacuum pump. Unscrew the studs from the rubber feet.

The inlet and exhaust of the vacuum pump are covered with plastic caps to prevent dirt and other foreign substances from entering to it. Leave these caps in place until you are ready to pipe the vacuum pump to your equipment.

2.3 Location

Install the vacuum pumps in a horizontal position on a level surface so that it can be evenly supported on its rubber feet. Leave 30 ~ 45 cm of access around the vacuum pump to allow proper cooling. Also, adequate ventilation must be provided for the cooling for the vacuum pump and motor.

Allow access to the oil sight glass in order to inspect the oil level regularly, and the oil fill and oil drain port for easy service.

2.4 Power Requirements

A schematic diagram for the electrical motor terminal connections is located in the junction box of the motor or on the motor nameplate. Typical wirings for Three Phase Motors are as below:

WIRING SCHEME- THREE PHASE MOTOR

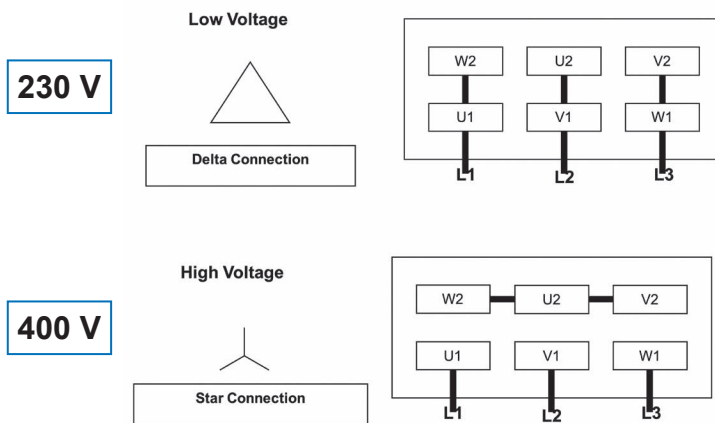

The motor must be connected according to the electrical codes through a fused switch in order to protect the motor against electrical or mechanical overload conditions. The overload of the motor starter must be set at a level equal to the full load motor current listed on the motor nameplate.

If the vacuum pump is supplied with a motor starter, it is preset at the factory according to customer specifications.

It is advisable to check that these settings are in line with the voltage at your location. If the voltage is different, please contact P.V.R for motor and starter information.

Correct direction of rotation is marked by an arrow on the motor fan housing and is counterclockwise when looking at the motor from the motor's fan side.

After electrical connections have been made, the rotation of the motor should be checked. If backward, reverse any two leads of the three at the power connection.



WARNING:

Motors should only be installed by a qualified electrician, who has experience in wiring three-phase motors. Improper electrical installation can cause injury or death.



CAUTION:

DRY CR pumps must not be allowed to run backwards. The splash lubrication system is not designed for backward operation and this may result in premature failure of the rotary claw machine.

Operating and maintenance instructions

EN

2.5 Vacuum Connections

Use a pipe size that is at least the size of the pump inlet connections. Smaller lines result in a reduced pump capacity.

Pumps operating in parallel on a common main line should have a manual or automatic operated shut-off valve or positive action check valve, installed in the suction line adjacent to the pump suction flange. The built-in anti-suck back valve should not be used as a shut-off valve for the vacuum system.

Remove the plastic protective cap from the inlet port prior to connection of pump to the system.

Should process gas contain dust or other foreign particles, a suitable in line (inlet) filter should be connected to the inlet port. Consult P.V.R. for recommendations. The vacuum piping should be designed to ensure that no liquids such a condensate or liquid carried over from the process can reach the pump. If this possibility exists, a knock-out liquid separator should be installed. Consult P.V.R. for recommendations.

The following thread sizes are standard on the pumps (NPT thread is available upon request)

Pump Model	Inlet Size	Exhaust Size
DRY CR 60	G 1"	G 1"
DRY CR 150	G 1-1/2"	G 1-1/2"
DRY CR 400	G 3"	G 3"
DRY CR 500	G 3"	G 3"
DRY CR 1000	DN 100	DN 100

2.6 Oil Filling on Gear Box

The pump is shipped without oil in gear box. After level installation and correct rotation has been established, fill the pump with recommended gear oil through the oil fill port. Oil level should be over 3/4 position on the oil sight glass as shown on the label.



Do not add fill oil with pump running! Do not overfill.



CAUTION:
Running the vacuum pumps before adding oil to the gearbox could result in severe damage to the unit. Use of oil that does not meet the recommended specification could result in damage to the unit and void the warranty.

Operating and maintenance instructions

EN

3. Safety

Please read the following safety notices carefully before operating the pump.

3.1 General Notices

- Understand fully this installation and operating manual before operation.
- The other person except authorized operator should not operate the vacuum pump.
- When the vacuum pump is not properly working, it should be stopped immediately.
- P.V.R. shall have no liability for any accident and failure arising from no compliance with instructions in this manual.

3.2 Warning labels and its explanation

3.2.1 Read and Understand a manual:

Read and understand operator's manual before using this machine.

3.2.2 Burn Hazard:

Hot surface. Do not touch.

3.2.3 Loud noise Hazard

Loud noise hazard. Ear protection must be worn.

3.2.4 Hazardous Voltage:

Disconnect power before opening. Contact causes severe electrical shock



3.3 Warning labels and its explanation

The warning labels shown above should be affixed on the top of the pump's sound shield, except the "Hazardous Voltage" label, which should appear on the cover of motor's terminal box.

4. Operation

4.1 Start-up

Check rotation of the motor as described in **Section 2.4** (Power Requirements). Fill the pump with oil as described in **Section 2.6** (Oil Filling).

Start the pump with the inlet closed. Run the pump for a few minutes and then shut down. Check the oil level again and make sure the oil level is over 3/4 position of oil sight glass as shown on the label. Add oil through oil fill port, if necessary. Pump oil should only be added when the pump is off.

4.2 Stopping the pump

To stop the pump, turn off the power. An anti-suck back valve (built-in) for these pumps installed in inlet flange will prevent the air from back flowing into the vacuum chamber after the pump is shutdown.



CAUTION:

Do not use the anti-suck back valves as a check valve. Consult P.V.R. for recommendations regarding check valves and other accessories.



CAUTION:

The maximum number of motor starts per hour should not exceed 10 per hour. Excessive starting of the motor can cause overheating and premature failure of the motor. A minimum run timer should be used with a control panel to regulate starting and stopping of the pump.



CAUTION:

In applications, where the quantity of water vapor is moderate, it is recommended to run the pump for 10 minutes at least with outside air prior to shut down to prevent the vapor from condensing in the pump.

4.3 Operating Conditions

All DRY CR units are designed to run at the vacuum levels for continuous operation as stated in Technical Data. Operating above the maximum vacuum level may cause severe damage to the machine. The vacuum regulator installed in inlet flange is set to the maximum allowable vacuum level at the factory, and a desired vacuum level below the maximum level can be achieved by rotating the adjustment knob.

Standard DRY CR units are for use of dry air only and should not be used for hazardous areas. Handling of humid air or gases containing aggressive chemicals is possible only with specially configured units. Consult P.V.R. for assistance.

Excessive back pressure on the unit may result in excessive current draw.

Do not operate the vacuum pump over 2 psi back pressure.

For operating personnel working near the pump, ear protection is recommended. If noise below the typical dBA is required, an external sound enclosure can be added to the system, provided adequate ventilation is provided. Please consult P.V.R. for recommendations.

The ambient and suction air temperature must be between 41° F (5° C) and 104° F (40° C).

Operating and maintenance instructions

EN



CAUTION: Failure to ensure proper operating conditions may lead to severe injury to persons and damage to the pump.



CAUTION: Maximum number of motor starts per hour should not exceed 10 per hour. Excessive starting of the motor can cause overheating and premature failure of the motor. A minimum run timer should be used with any panel that may control the pump with automatic starts and stops based on system pressures.



CAUTION: In applications, where the quantity of water vapor is moderate, it is recommended to run the pump for 10 minutes at least with outside air prior to shut down to prevent the vapor from condensing in the pump.



CAUTION: Do not run the compressor without regulating valve or safety valve. Do not set the regulating valve or safety valve at over permissible pressure. The compressor may be damaged severely.

5. Maintenance

DRY CR-Series vacuum pump require very little maintenance. To ensure optimum performance, the following maintenance steps should be followed:

5.1 Gear Box Lube Oil

5.1.1 Gear Oil Level

Check the oil level on monthly basis. Under normal circumstances it should not be necessary to add oil between oil changes. A significant drop in oil level could indicate an oil leak. If the pump is leaking oil, please check the o-rings, drain plug or oil sight glass.

Check the oil level only when the pump is shut off. Replenish oil if it drops below bottom position of the oil sight glass.



CAUTION: Do not add oil while the pump is running. Hot oil can escape from the oil fill port.

5.1.2 Gear Oil Type and Quantity

Oil level should be at the 3/4 position on the oil sight glass.

The following table gives the approximate quantities of oil required for each model.

Pump Model	Oil Model	Capacity (liter)	Ambient temperature [°C]
DRY CR 60	Rotant VF 805	0.60	5-30°C
DRY CR 150		0.40	
DRY CR 400		1.80	
DRY CR 500		1.80	
DRY CR 1000		2.80	



**Do not add fill oil with pump running!
Do not overfill.**

5.1.3 Gear Oil Change

Under normal ambient conditions with proper gear oil, oil needs to change the oil every 10,000 operating hours. We recommend performing the first oil change after 500 - 1,000 operating hours.



CAUTION:
If different brand of oil is being filled, the old oil must be drained completely from the gear box.



CAUTION:
The interval of lubrication stated above is based on ambient temperature of 20°C (68°F). At 40°C (104°F) ambient temperature, the interval may be reduced to 2,500 operating hours.

5.2 Inline (Inlet) Filter

Check inline (inlet) filter on a weekly basis. The filter cartridge should be cleaned or replaced if it is dirty. Consult P.V.R. for replacement elements.



CAUTION:
Depending on the mounting position of the filter, be careful not to allow accumulated foreign material to fall in the pump suction inlet when removing the filter cartridge. Horizontal filter installation is recommended to prevent this.

Operating and maintenance instructions

EN

5.3 Maintenance Chart

Weekly	Check inline inlet filter element/mesh. (this might need to be performed more often if there are high particulates in the inlet stream)
Monthly	Check the oil level and protective mesh.
Semi-Annually	Check fans and coupling. Inspection hole with G1" plug: Check the coupling and its insert, and fan through this hole regularly. (The endoscope (WireCam) can be used with Smart Phone software).
Annually	Check Bearings/ Shaft Seals, (this might need to be performed more often if the unit is operating at ambient temperature that exceeds 20°C (68°F).
Every 1500 operating hours	Check grease conditions and add additional grease if necessary, especially if the unit is being operated at an ambient temperature that exceeds 20°C (68°F).
Every 5000 operating hours	Check the gear oil conditions, and if necessary, change the oils.

6. Troubleshooting

Problem	Probable Cause	Remedy
Motor Starter Trips	Incorrect voltage (lower than required).	Check voltage at the motor and correct any sources of voltage drop in the system. Check wiring to ensure it is properly sized according to National Electrical Code requirements.
	Incorrect wiring of the motor.	Ensure the motor is wired according to the instructions contained in the motor junction box. Correct placement of the bridges is necessary to configure your motor for the proper voltage.
	Motor starter is not set correctly or is too small for the application.	Check to ensure the motor starter is set for the full load amps at the operating voltage as indicated on the motor nameplate. Be sure to multiply the full load amperage by any service factor that appears on the motor. If the current required is outside the range of adjustability of the starter, replace the starter with a properly sized starter.
	Motor starter trips too fast.	A motor starter with a high current trip delay should be used to avoid nuisance trips on startup.

Problem	Probable Cause	Remedy
Insufficient Capacity	Blocked inlet mesh	Check and clean mesh as necessary. Replace damaged mesh. Do not run the machine without the inlet mesh in place, as even small solids entering the pumping chamber can cause the unit to fail.
	Leaks in the vacuum piping	Check process piping for leaks. To confirm the leaks are in the piping, run the pump isolated from the piping and confirm pump reaches ultimate vacuum per the data sheets. If the pump does meet the ultimate vacuum, then there is a problem in the piping that must be corrected. A rate of rise test can be run to determine the leakage rate. Leaks can be found by a soapy water or smoke test.
Insufficient Capacity (cont'd)	Improperly operating relief valve	Check the adjustment of the relief valve. Under normal conditions, the DRY CR should not have air flowing into the relief valve if operating in the standard range of pressures. If air is detected entering the relief valve (place a cardboard scrap near the suction of the relief valve and see if vacuum is detected – if the scrap is held to the relief valve by the vacuum, then the relief valve is active). If the relief valve is active, adjust it so that no flow is detected at the operating pressure, which must be in the range of operation shown on the data sheet.
Insufficient Vacuum	Blocked inlet mesh	(See blocked inlet mesh above)
	Improperly operating relief valve	See Improperly operating relief valve, above.
	Bad gauge	Replace the gauge with a good quality vacuum or pressure gauge.
	Leaks in the system piping.	Check the connection pipes
	Improperly sized piping.	Check the pressure at the pump and at the process with the same gauge. If the pressure drop exceeds the design value (rule of thumb is 10 percent of the operating pressure, maximum) then the piping is too small. Change the piping between the pump and the process to a larger size.
Pump does not achieve ultimate vacuum	Leak on the suction side	Check the piping for leaks as noted above.
	Relief valve set incorrectly.	Reset the relief valve as necessary.
	Bad gauge	Replace the gauge with a better-quality vacuum gauge.
The pump will not start.	Supply voltage is not proper or is overloaded. Motor starter overload settings are too low or improper; fuses are burned; wire size is too small or too long causing a voltage drop.	Check voltage supply; overload settings in motor starter for size and settings according to motor nameplate. Install proper size wire. If ambient temperature is high, use the next larger size overloads, or adjust settings 5% above motor nameplate value. Remedy. Repair or replace if needed or call service agent for service or exchange program.

Operating and maintenance instructions

EN

Problem	Probable Cause	Remedy
Operating Temperature too High	Ambient temperature too high	Provide adequate ventilation for the installation area so that the ambient temperature never is above 40°C (104°F).
	Dirty or Blocked Mesh	(See blocked inlet mesh above)
Pump runs over set pressure.	Vacuum regulator set over the set point or is out of order.	Set the point again or replace it with new one.
Pump making excessive noise	Contamination of the claws	Clean the pumping chamber and rotary claws.
	Coupling insert is worn.	Replace coupling insert in motor/pump coupling.
Pump will not operate (seized up).	Rotary Claws, Bearings or Gears stuck	Call P.V.R. for service or exchange program

7. De-commissioning

Drain the oil from the pump prior to the removal.

If the oil is polluted, flush the pump with fresh oil (see “oil change”).

Drain the oil from the tank, plug the inlet and the discharge ports and store the pump without oil.

In case of pump disposal, separate the pump parts by materials and trash the parts in accordance with the local regulations in the Country of use.

8. Return for repair

In case of pump return for repair to P.V.R., provide a list of substances which have come in contact with the pump and advise the risks involved in handling, if any. Drain the lubricant from the pump prior to shipping the pump back.

9. Disposal

Meaning of the “WEEE” logo found in labels

The following symbol is applied in accordance with the EC WEEE (Waste Electrical and Electronic Equipment) Directive.

This symbol (valid only in countries of the European Community) indicates that the product it applies to must NOT be disposed of together with ordinary domestic or industrial waste but must be sent to a differentiated waste collection system.

The end user is therefore invited to contact the supplier of the device, whether the Parent Company or a retailer, to initiate the collection and disposal process after checking the contractual terms and conditions of sale.





PVR Srl

HEADQUARTERS:

Via Santa Vecchia, 107 - 23868 Valmadrera (LC), Italy
T +39 0341 1918 51 - F +39 0341 1918 599
info@pvr.it - www.pvr.it

LOCAL UNIT:

Via IV Novembre, 104F
23868 Valmadrera (LC), Italy